

Electrobombas centrífugas normalizadas "EN 733"

 Agua limpia

 Utilizo industrial



CAMPO DE PRESTACIONES

- Caudal hasta **3000 l/min** (180 m³/h)
- Altura manométrica hasta **24 m**

LÍMITES DE UTILIZO

- Altura de aspiración manométrica hasta **7 m**
- Temperatura del líquido de **-10 °C** hasta **+90 °C**
- Temperatura ambiente de **-10 °C** hasta **+40 °C**
- Presión máxima en el cuerpo bomba **10 bar** (PN10)
- Funcionamiento continuo **S1**

EJECUCION Y NORMAS DE SEGURIDAD

EN 60335-1
IEC 60335-1
CEI 61-150

EN 60034-1
IEC 60034-1
CEI 2-3



Dimensiones del cuerpo de la bomba conformes a la norma **EN 733**

REGLAMENTO (UE) N. 547/2012

CERTIFICACIONES

Empresa con sistema de gestión certificado DNV
ISO 9001: CALIDAD



UTILIZOS E INSTALACIONES

- Abastecimiento hídrico
- Presurización
- Irrigación
- Circulación del agua en instalaciones de climatización
- Instalaciones de lavado
- Instalaciones Anti Incendio
- Industria
- Agricultura

La instalación se debe realizar en lugares cerrados, bien aireados y protegidos de la intemperie.

EJECUCION BAJO PEDIDO

- KIT contrabridas completo de tornillos, tuercas y juntas
- Otros voltajes o frecuencia 60 Hz
- Para líquidos con temperaturas más altas o más bajas
- Para ambientes con temperaturas más altas o más bajas

GARANTIA

2 años según nuestras condiciones generales de venta

CAMPO DE PRESTACIONES

50 Hz n = 1450 min⁻¹

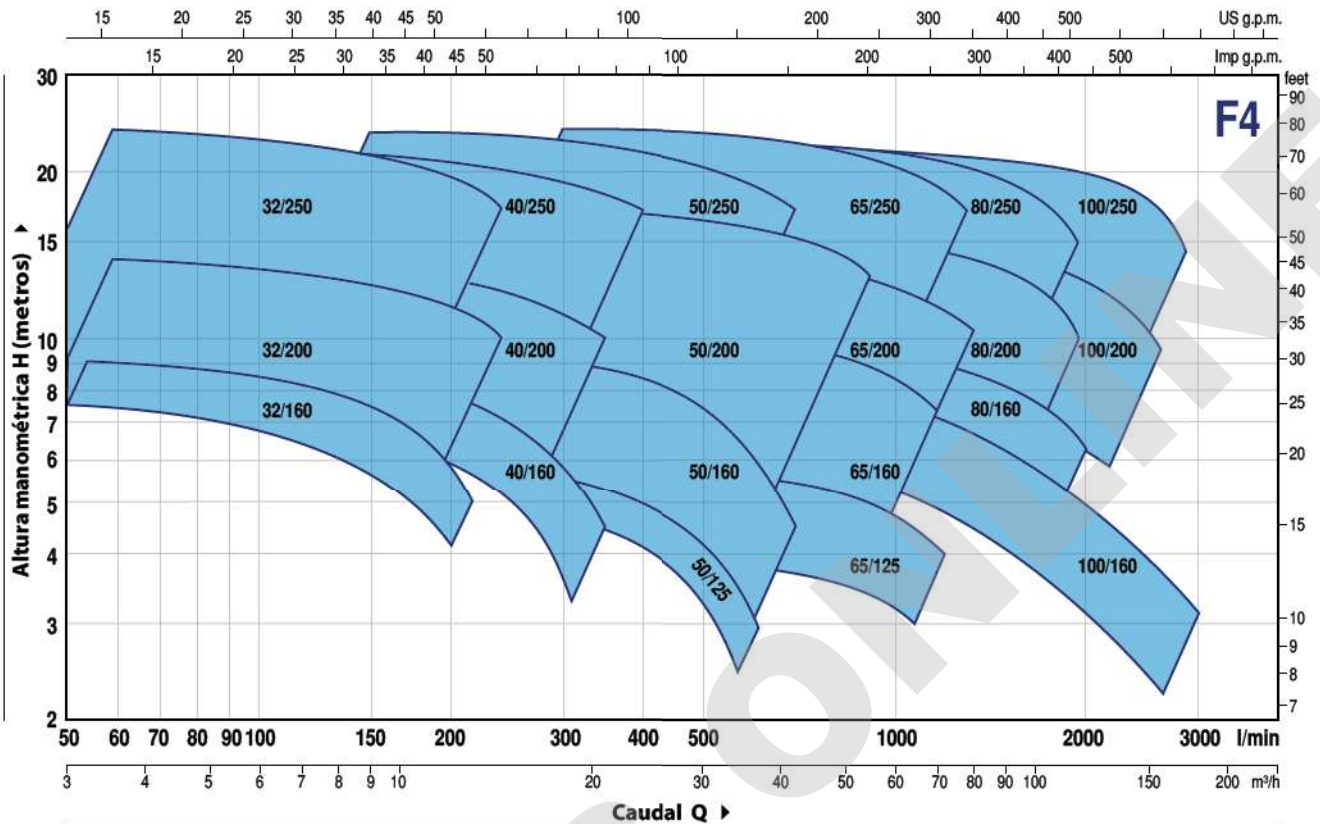

DATOS DE PRESTACIONES

50 Hz n = 1450 min⁻¹

MODELO	POTENCIA (P ₂)		▲	PRESTACIONES	
	kW	HP		Q l/min	H metros
F4-32/160B	0.37	0.5	IE2	50 – 200	7.5 – 4.5
F4-32/160A	0.37	0.5		50 – 225	9 – 5
F4-32/200B	0.75	1	IE3	50 – 250	12.5 – 9
F4-32/200A	1.1	1.5		50 – 250	14 – 10.5
F4-32/200BH	0.75	1	IE3	50 – 150	11.3 – 9.2
F4-32/200AH	0.75	1		50 – 160	13.8 – 11
F4-32/250C	1.1	1.5	IE3	50 – 220	18.4 – 15
F4-32/250B	1.5	2		50 – 250	21.7 – 17.4
F4-32/250A	2.2	3	IE3	50 – 270	23.8 – 18.7
F4-40/160B	0.37	0.5		50 – 320	7.5 – 3.5
F4-40/160A	0.55	0.75	IE2	50 – 350	9 – 4.5
F4-40/200B	0.75	1		50 – 350	11.5 – 7
F4-40/200A	1.1	1.5	IE3	50 – 350	13.8 – 10
F4-40/250C	1.1	1.5		50 – 400	15.5 – 10
F4-40/250B	1.5	2	IE3	50 – 400	17.5 – 12
F4-40/250A	2.2	3		50 – 400	22 – 17
F4-50/125B	0.55	0.75	IE2	150 – 600	5 – 2
F4-50/125A	0.55	0.75		150 – 600	6 – 3
F4-50/160B	0.75	1	IE3	150 – 650	8 – 3.8
F4-50/160A	1.1	1.5		150 – 700	9.3 – 4.5
F4-50/200C	1.5	2	IE3	200 – 850	11 – 7.5
F4-50/200B	2.2	3		200 – 850	13 – 9.5
F4-50/200A	2.2	3	IE3	200 – 900	15 – 11.2
F4-50/200AR	3	4		200 – 900	17 – 13.2
F4-50/250D	1.1	1.5	IE3	150 – 650	12.5 – 5
F4-50/250C	1.5	2		150 – 700	14 – 5
F4-50/250B	2.2	3	IE3	150 – 700	18 – 10.5
F4-50/250A	2.2	3		150 – 700	20 – 13
F4-50/250AR	3	4	IE3	150 – 700	23.5 – 17

MODELO	POTENCIA (P ₂)		▲	PRESTACIONES	
	kW	HP		Q l/min	H metros
F4-65/125B	0.75	1	IE3	300 – 1100	4.7 – 3
F4-65/125A	1.1	1.5		300 – 1200	5.7 – 4
F4-65/160C	1.1	1.5	IE3	300 – 1100	7.5 – 5.5
F4-65/160B	1.5	2		300 – 1200	9.1 – 5.7
F4-65/160A	2.2	3	IE3	300 – 1200	10.1 – 7
F4-65/200A	2.2	3		300 – 1250	12 – 8.5
F4-65/200AR	3	4	IE3	300 – 1300	14 – 10
F4-65/250B	4	5.5		200 – 1250	21.8 – 15.5
F4-65/250A	5.5	7.5	IE3	200 – 1300	23.5 – 17
F4-80/160D	1.5	2		300 – 2000	6.3 – 2.5
F4-80/160C	2.2	3	IE3	300 – 2000	7.5 – 3.8
F4-80/160B	2.2	3		300 – 2000	8.8 – 5
F4-80/160A	3	4	IE3	300 – 2000	10 – 6.2
F4-80/200B	4	5.5		300 – 1800	14 – 9
F4-80/200A	5.5	7.5	IE3	300 – 1900	15.5 – 10.5
F4-80/250B	5.5	7.5		300 – 1800	19.5 – 13.5
F4-80/250A	7.5	10	IE3	300 – 1950	22 – 15
F4-100/160B	2.2	3		400 – 2600	8.3 – 3.5
F4-100/160A	3	4	IE3	400 – 2800	10 – 4.7
F4-100/200C	4	5.5		400 – 2300	12.7 – 7
F4-100/200B	5.5	7.5	IE3	400 – 2400	14.2 – 8.5
F4-100/200A	5.5	7.5		400 – 2600	15.8 – 9.5
F4-100/250B	7.5	10	IE3	400 – 2600	18.5 – 11.5
F4-100/250A	9.2	12.5		400 – 2900	22 – 13.5

Q = Caudal

H = Altura manométrica total

Tolerancia de las curvas de prestación según EN ISO 9906 Grado 3B.

▲ Clase de rendimiento del motor trifásico (IEC 60034-30-1)

CURVAS Y DATOS DE PRESTACIONES

50 Hz n= 1450 min⁻¹ HS= 0 m

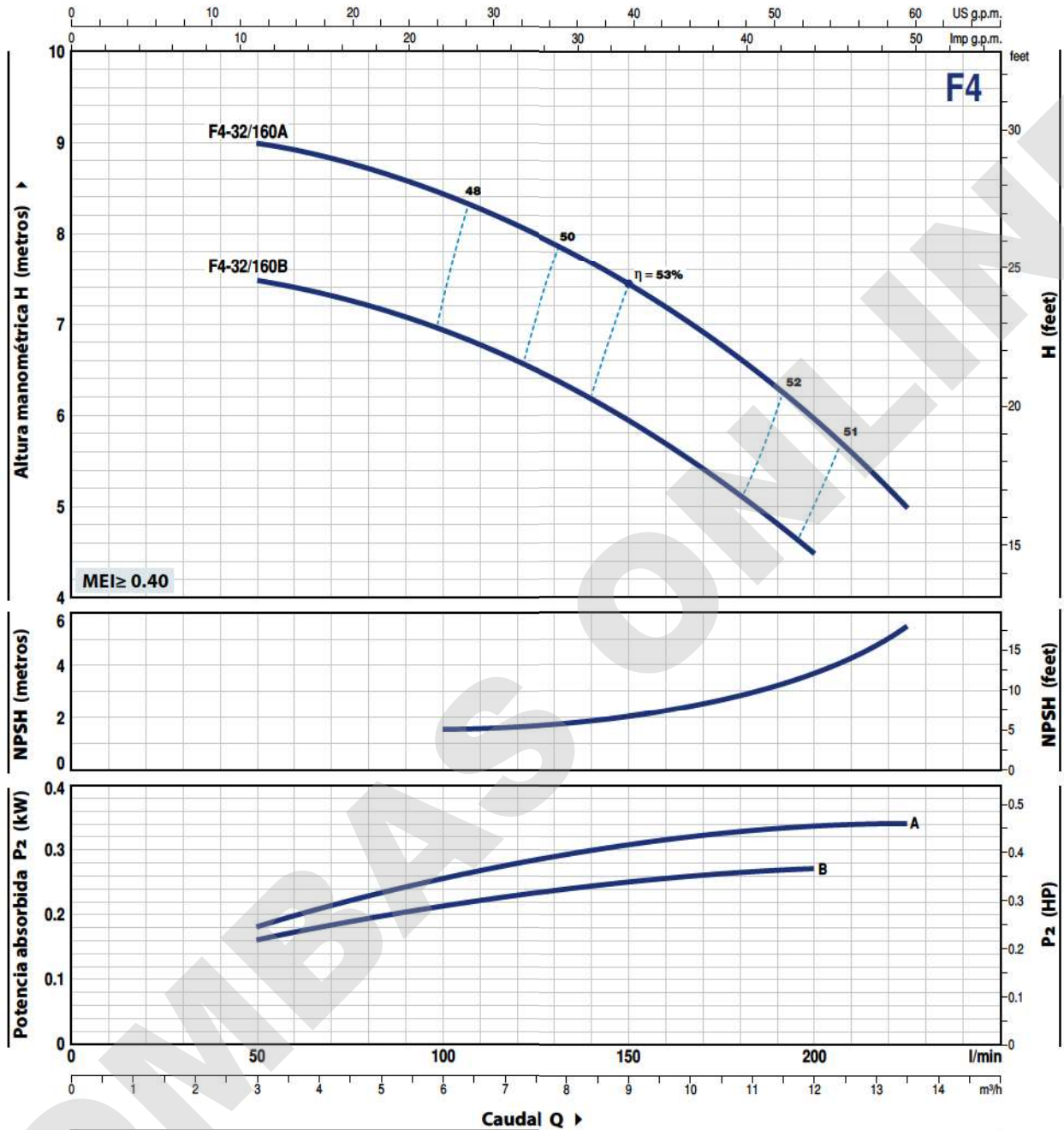

MODELO	POTENCIA (P ₂)		Q	Caudal Q										
	kW	HP		m ³ /h	3	4.5	6	7.5	9	10.8	12	13.5		
Trifásica			l/min	50	75	100	125	150	180	200	225			
F4-32/160B	0.37	0.5	H metros	7.5	7.3	6.9	6.5	6	5.1	4.5				
F4-32/160A	0.37	0.5		9	8.8	8.4	8	7.5	6.6	6	5			

Q = Caudal H = Altura manométrica total HS = Altura de aspiración

Tolerancia de las curvas de prestación según EN ISO 9906 Grado 3B.

CURVAS Y DATOS DE PRESTACIONES

50 Hz n= 1450 min⁻¹ HS= 0 m

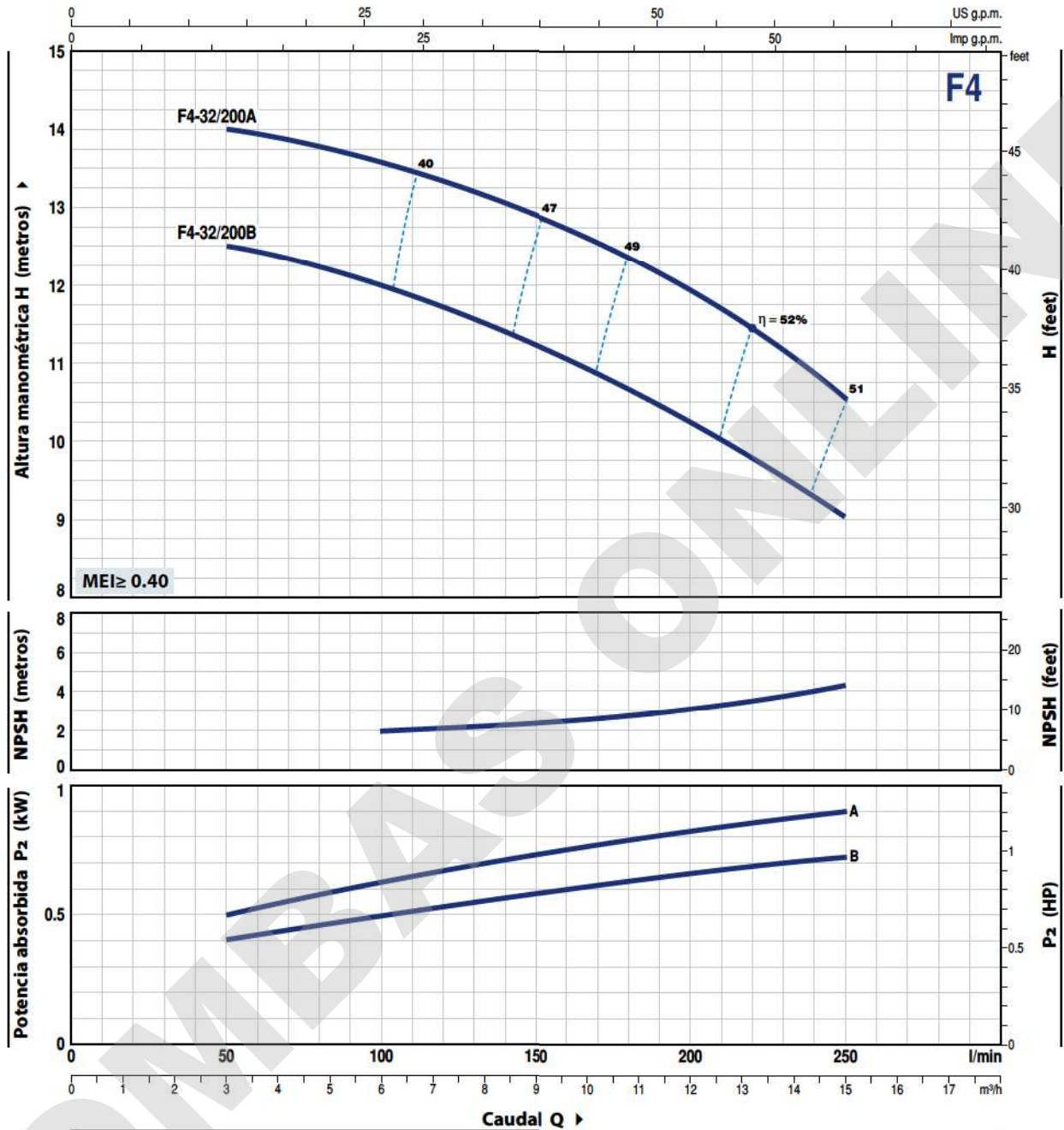

MODELO	POTENCIA (P ₂)		Q	Caudal Q						
	kW	HP		m ³ /h	l/min	3	6	9	12	15
Trifásica				50	100	150	200	250		
F4-32/200B	0.75	1	H metros		12.5	12	11.2	10.3	9	
F4-32/200A	1.1	1.5			14	13.6	12.8	11.9	10.5	

Q = Caudal H = Altura manométrica total HS = Altura de aspiración

Tolerancia de las curvas de prestación según EN ISO 9906 Grado 3B.

F4-32/200H

CURVAS Y DATOS DE PRESTACIONES

50 Hz n = 1450 min⁻¹ HS = 0 m

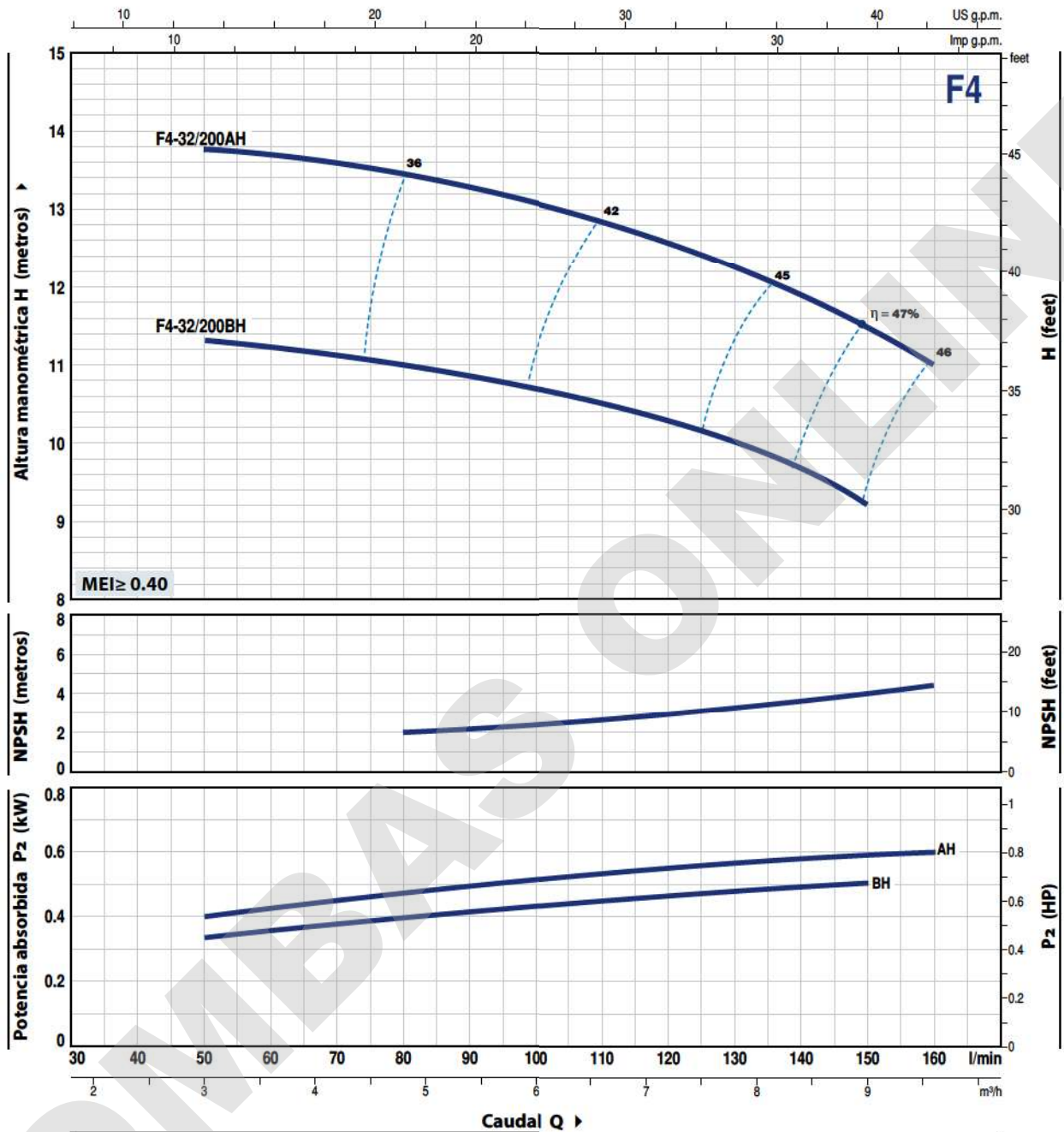

MODELO	POTENCIA (P ₂)		Q	Caudal								
	kW	HP		m ³ /h	l/min	3	4.2	5.4	6.6	7.8	9	9.6
Trifásica				50	70	90	110	130	150	160		
F4-32/200BH	0.75	1	H metros	11.3	11.1	10.8	10.5	10	9.2			
F4-32/200AH	0.75	1	H metros	13.8	13.6	13.3	12.8	12.2	11.5	11		

Q = Caudal H = Altura manométrica total HS = Altura de aspiración

Tolerancia de las curvas de prestación según EN ISO 9906 Grado 3B.

CURVAS Y DATOS DE PRESTACIONES

50 Hz n= 1450 min⁻¹ HS= 0 m

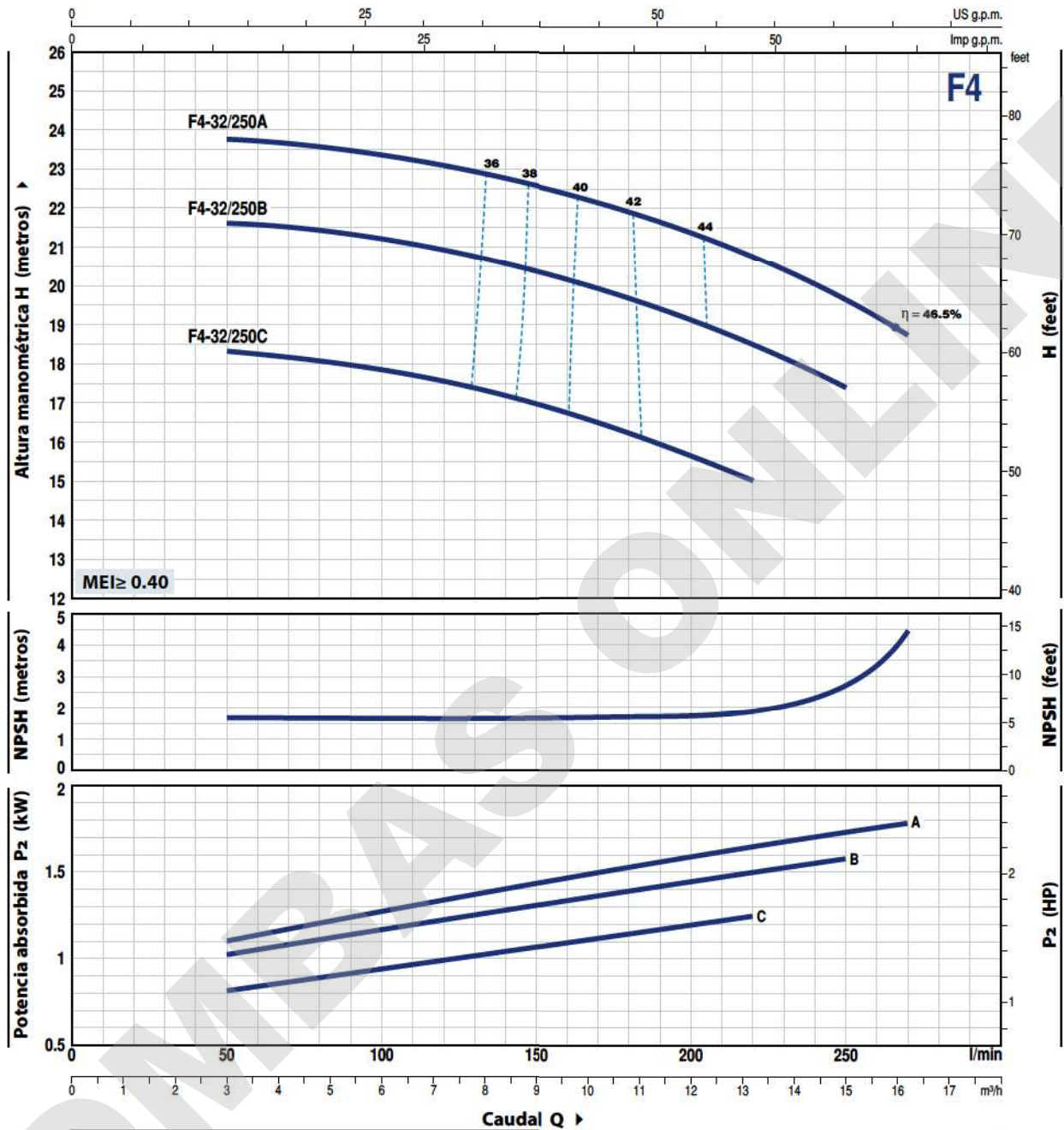

MODELO	POTENCIA (P ₂)		Q	Q										
	kW	HP		m ³ /h	3	4.5	6	7.5	9	10.5	13.2	15	16.2	
Trifásica			l/min	50	75	100	125	150	175	220	250	270		
F4-32/250C	1.1	1.5	H metros		18.4	18.1	17.8	17.5	17	16.4	15			
F4-32/250B	1.5	2			21.7	21.5	21.2	20.9	20.4	19.8	18.5	17.4		
F4-32/250A	2.2	3			23.8	23.6	23.4	23	22.6	22.1	20.8	19.6	18.7	

Q=Caudal H=Altura manométrica total HS= Altura de aspiración

Tolerancia de las curvas de prestación según EN ISO 9906 Grado 3B.

CURVAS Y DATOS DE PRESTACIONES

50 Hz n= 1450 min⁻¹ HS= 0 m

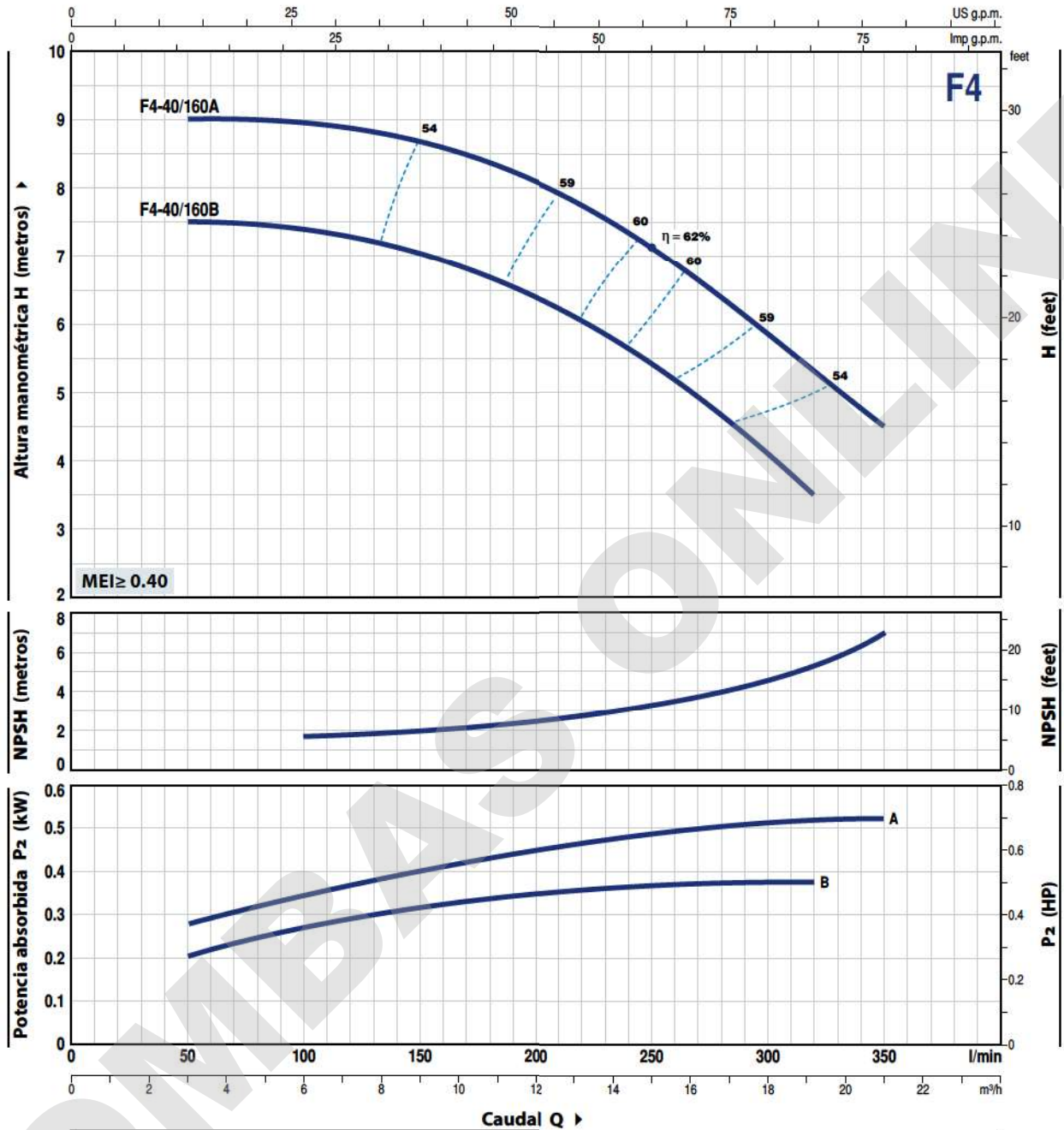

MODELO	POTENCIA (P ₂)		Q	Caudal								
	kW	HP		m ³ /h	3	6	9	12	15	18	19.2	21
Trifásica			l/min	50	100	150	200	250	300	320	350	
F4-40/160B	0.37	0.5	H metros	7.5	7.4	7	6.4	5.4	4.1	3.5		
F4-40/160A	0.55	0.75		9	8.9	8.7	8.1	7.1	5.8	5.3	4.5	

Q = Caudal H = Altura manométrica total HS = Altura de aspiración

Tolerancia de las curvas de prestación según EN ISO 9906 Grado 3B.

CURVAS Y DATOS DE PRESTACIONES

50 Hz n= 1450 min⁻¹ HS= 0 m

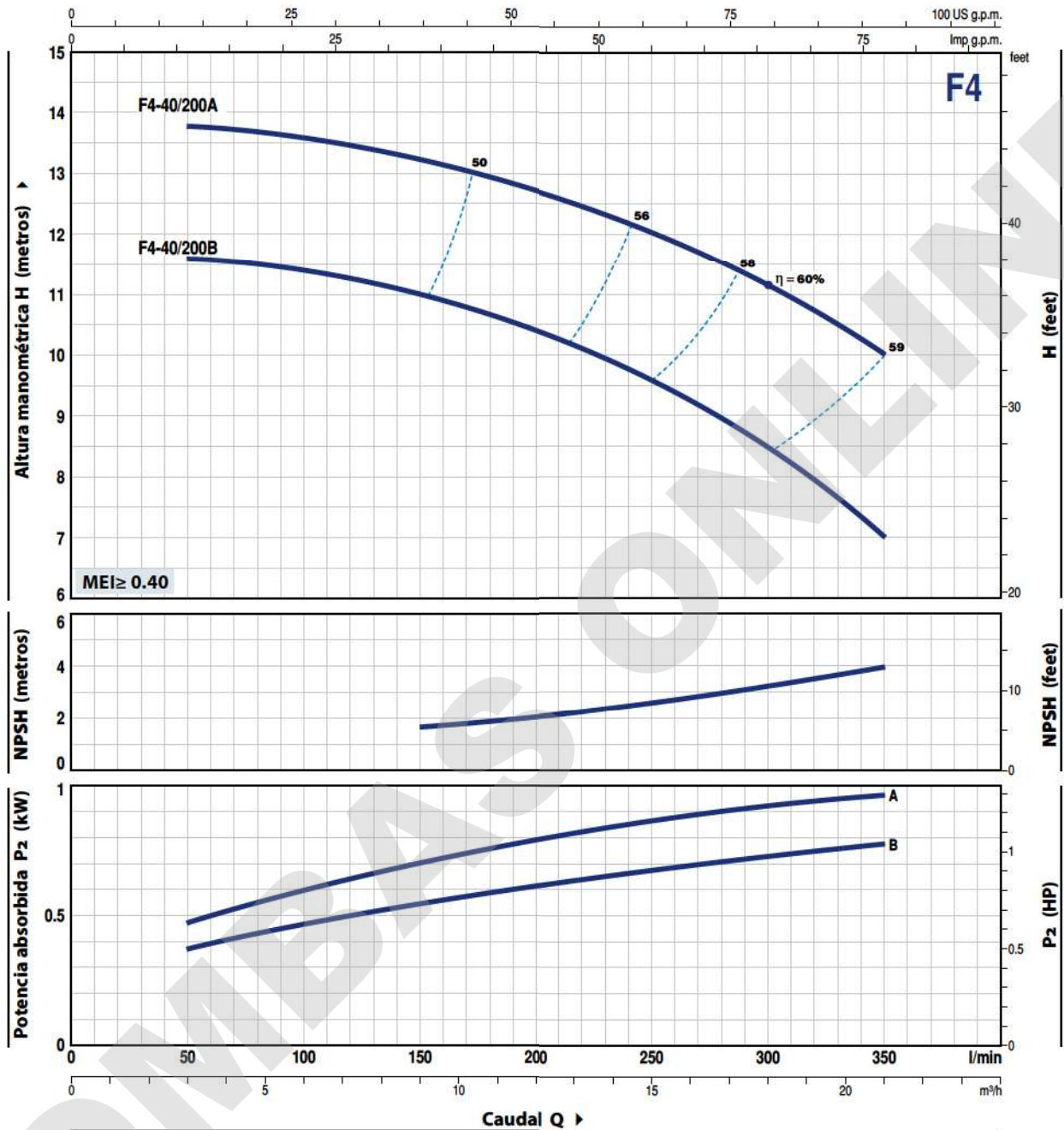

MODELO	POTENCIA (P ₂)		Q	Q							
	kW	HP		m ³ /h	3	6	9	12	15	18	21
Trifásica			l/min	50	100	150	200	250	300	350	
F4-40/200B	0.75	1	H metros	11.5	11.4	11	10.4	9.5	8.5	7	
F4-40/200A	1.1	1.5		13.8	13.6	13.2	12.7	12	11.1	10	

Q = Caudal H = Altura manométrica total HS = Altura de aspiración

Tolerancia de las curvas de prestación según EN ISO 9906 Grado 3B.

CURVAS Y DATOS DE PRESTACIONES

50 Hz n= 1450 min⁻¹ HS= 0 m

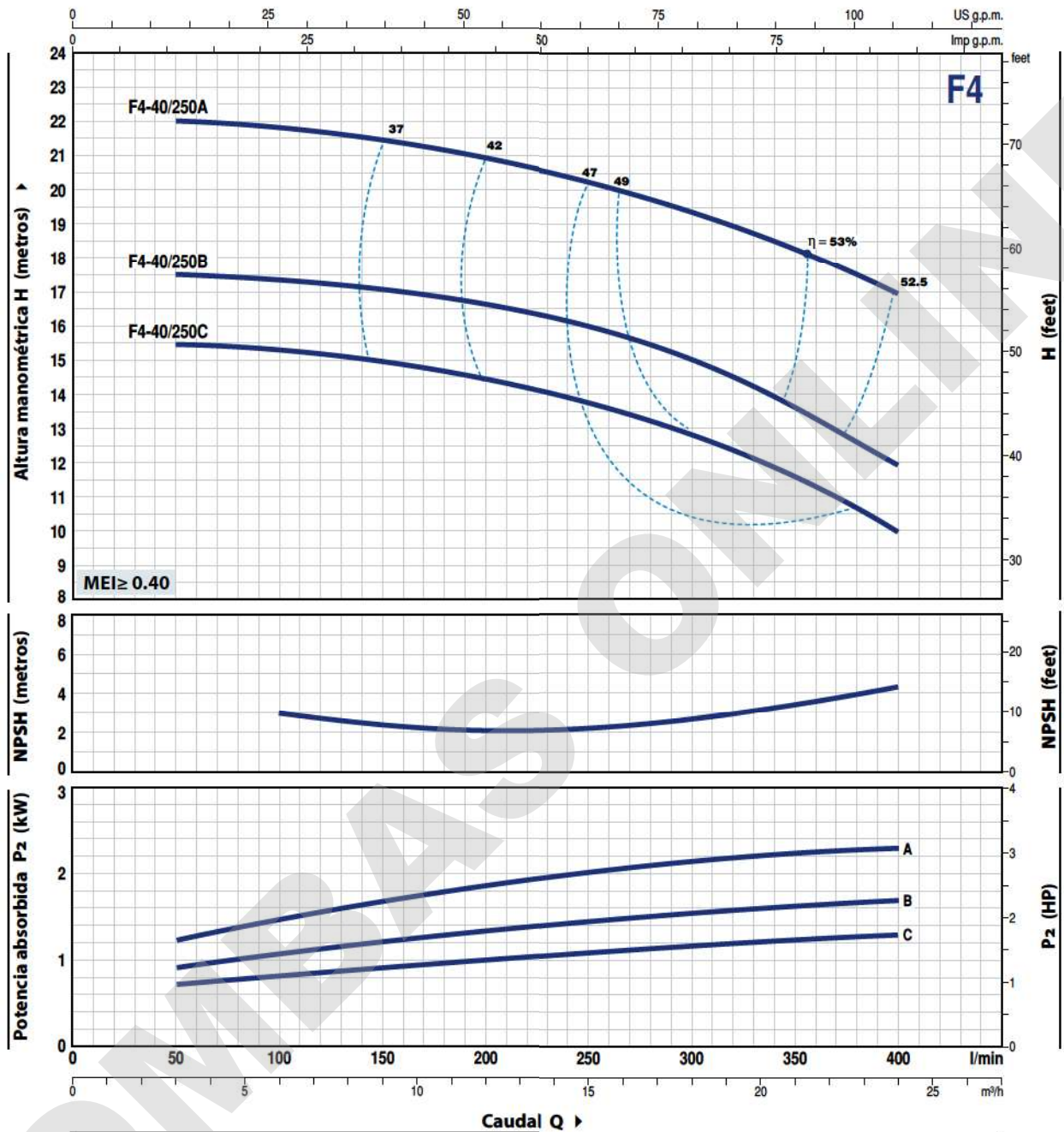

MODELO	POTENCIA (P ₂)		Q	Q										
	kW	HP		m ³ /h	3	6	9	12	15	18	21	24		
Trifásica			l/min	50	100	150	200	250	300	350	400			
F4-40/250C	1.1	1.5	H metros	15.5	15.2	15	14.5	13.6	12.9	11.5	10			
F4-40/250B	1.5	2		17.5	17.2	17	16.5	16	15	13.5	12			
F4-40/250A	2.2	3		22	21.9	21.5	21	20.2	19.2	18.2	17			

Q=Caudal H=Altura manométrica total HS= Altura de aspiración

Tolerancia de las curvas de prestación según EN ISO 9906 Grado 3B.

CURVAS Y DATOS DE PRESTACIONES

50 Hz n= 1450 min⁻¹ HS= 0 m

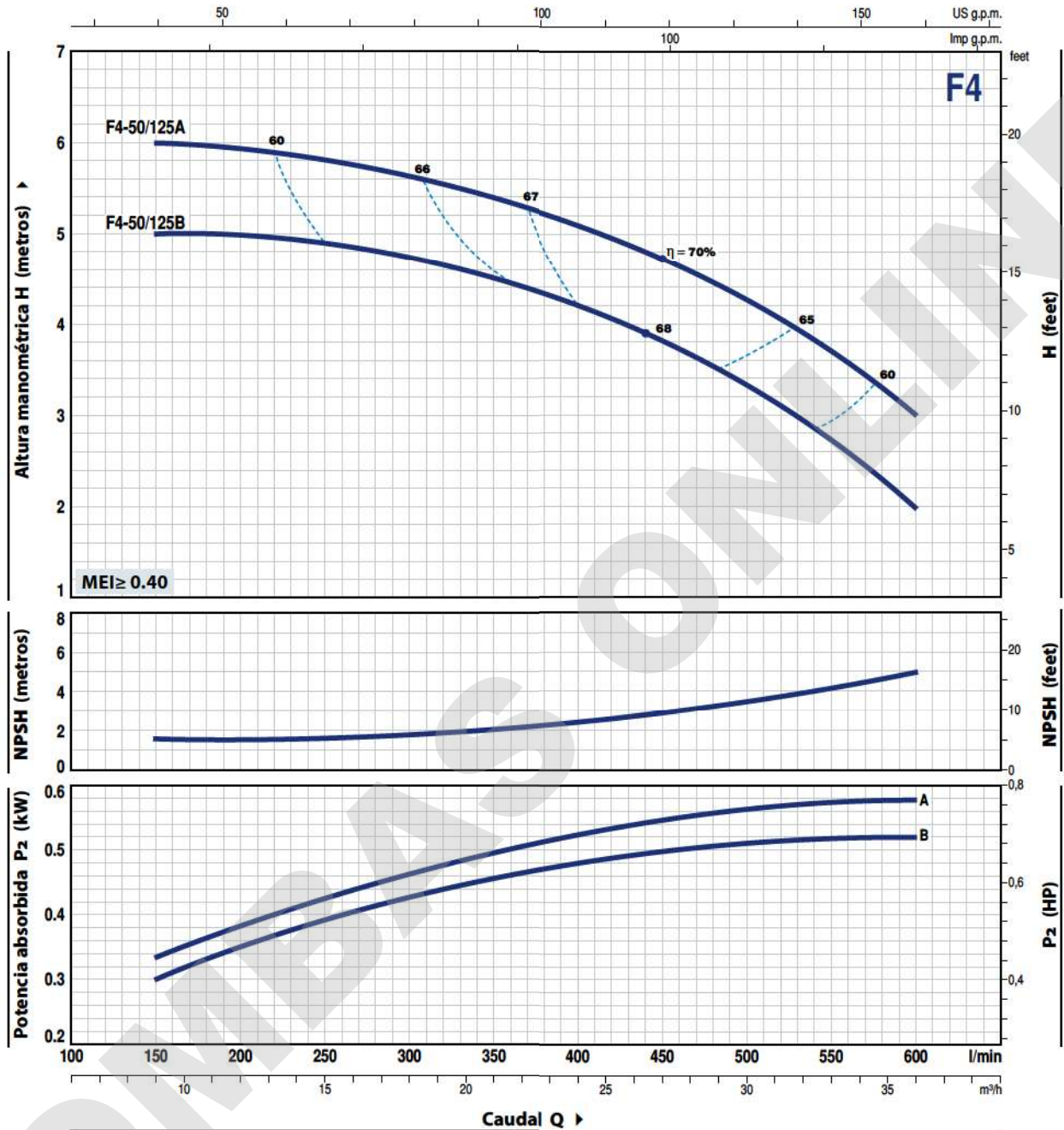

MODELO	POTENCIA (P ₂)		Q	Flow (Q)											
	kW	HP		m ³ /h	9	12	15	17	21	24	27	30	33	36	
Trifásica			l/min	150	200	250	300	350	400	450	500	550	600		
F4-50/125B	0.55	0.75	H metros	5	5	4.9	4.7	4.5	4.2	3.8	3.3	2.7	2		
F4-50/125A	0.55	0.75		6	5.9	5.8	5.6	5.4	5.1	4.7	4.2	3.7	3		

Q = Caudal H = Altura manométrica total HS = Altura de aspiración

Tolerancia de las curvas de prestación según EN ISO 9906 Grado 3B.

CURVAS Y DATOS DE PRESTACIONES

50 Hz n= 1450 min⁻¹ HS= 0 m

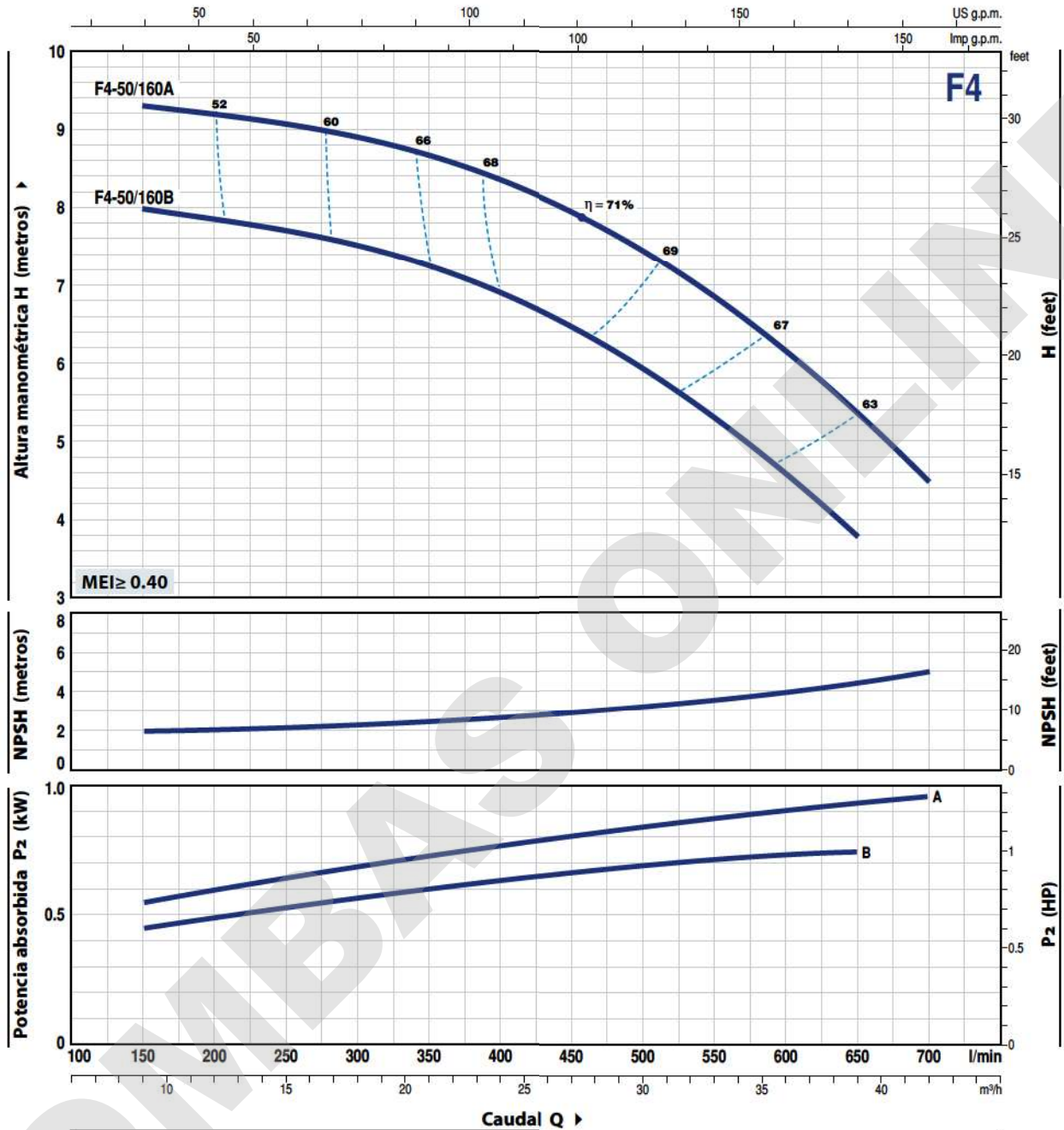

MODELO	POTENCIA (P ₂)		Q	Caudal													
	kW	HP		m ³ /h	9	12	15	17	21	24	27	30	33	36	39	42	
Trifásica			l/min	150	200	250	300	350	400	450	500	550	600	650	700		
F4-50/160B	0.75	1	H metros	8	7.8	7.7	7.5	7.2	6.9	6.5	5.9	5.3	4.6	3.8			
F4-50/160A	1.1	1.5		9.3	9.2	9.1	8.9	8.7	8.4	8	7.4	6.8	6.2	5.4	4.5		

Q = Caudal H = Altura manométrica total HS = Altura de aspiración

Tolerancia de las curvas de prestación según EN ISO 9906 Grado 3B.

CURVAS Y DATOS DE PRESTACIONES

50 Hz n = 1450 min⁻¹ HS = 0 m

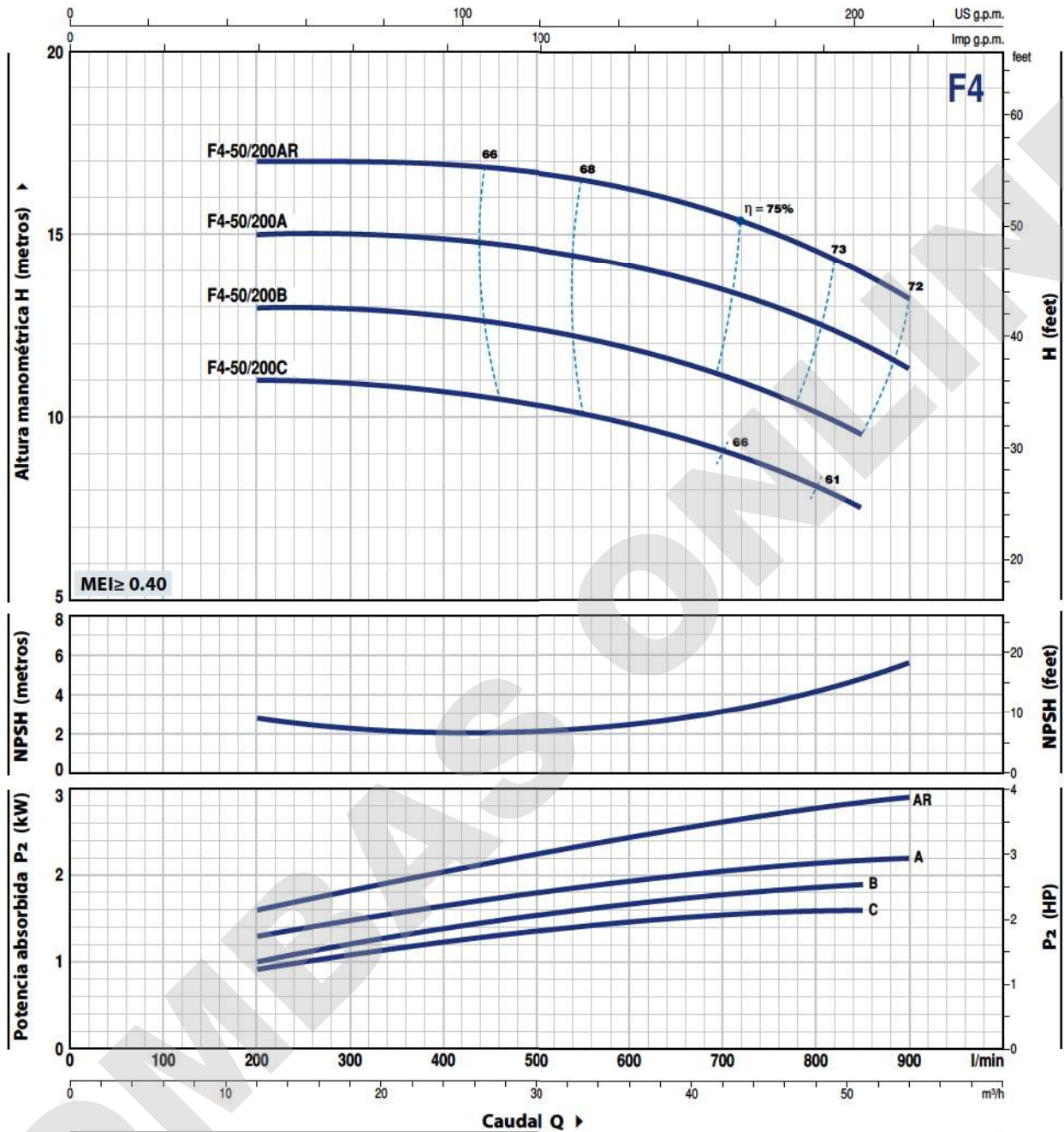

MODELO	POTENCIA (P ₂)		Q	H metros											
	kW	HP		m ³ /h	12	17	24	30	36	42	48	51	54		
Trifásica			l/min	200	300	400	500	600	700	800	850	900			
F4-50/200C	1.5	2		11	11	10.8	10.3	9.8	9	8	7.5				
F4-50/200B	2.2	3		13	13	12.8	12.4	11.9	11.1	10.1	9.5				
F4-50/200A	2.2	3		15	15	14.9	14.6	14.1	13.5	12.5	12	11.2			
F4-50/200AR	3	4		17	17	16.9	16.7	16.2	15.5	14.5	14	13.2			

Q = Caudal H = Altura manométrica total HS = Altura de aspiración

Tolerancia de las curvas de prestación según EN ISO 9906 Grado 3B.

CURVAS Y DATOS DE PRESTACIONES

50 Hz n= 1450 min⁻¹ HS= 0 m

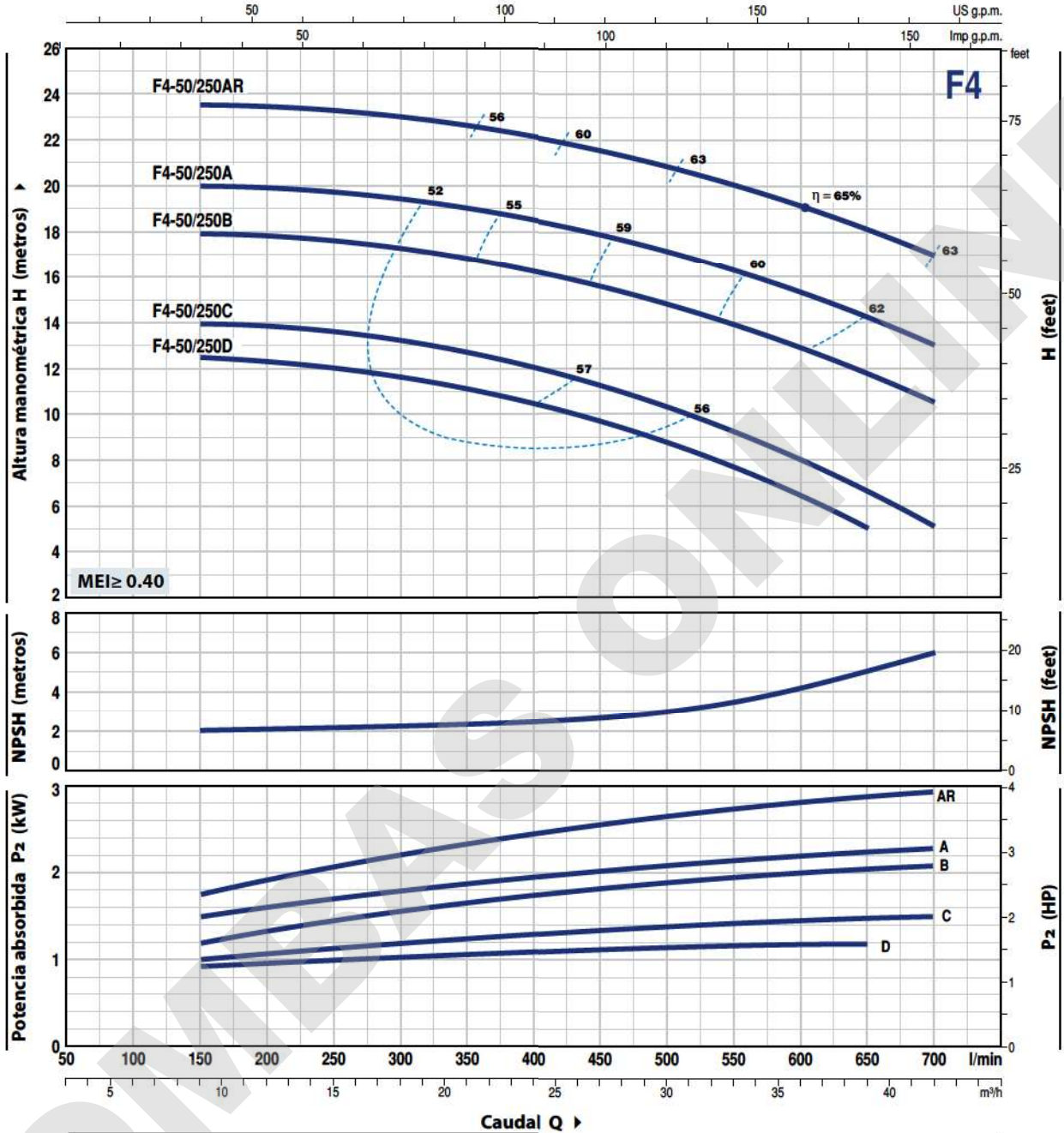

MODELO	POTENCIA (P ₂)		Q	m ³ /h													
	kW	HP		9	12	15	18	21	24	27	30	33	36	39	42		
Trifásica			l/min	150	200	250	300	350	400	450	500	550	600	650	700		
F4-50/250D	1.1	1.5	H metros	12.5	12.3	12	11.5	11.1	10.5	9.8	8.8	7.8	6.5	5			
F4-50/250C	1.5	2		14	13.9	13.6	13.2	12.8	12	11.2	10.2	9.2	8	6.6	5		
F4-50/250B	2.2	3		18	17.9	17.6	17.2	16.8	16.2	15.5	14.8	14	13	11.8	10.5		
F4-50/250A	2.2	3		20	19.9	19.7	19.5	19	18.5	18	17.2	16.2	15.3	14.2	13		
F4-50/250AR	3	4		23.5	23.4	23.2	23	22.6	22.1	21.6	21	20	19	18	17		

Q=Caudal H=Altura manométrica total HS= Altura de aspiración

Tolerancia de las curvas de prestación según EN ISO 9906 Grado 3B.

CURVAS Y DATOS DE PRESTACIONES

50 Hz n= 1450 min⁻¹ HS= 0 m

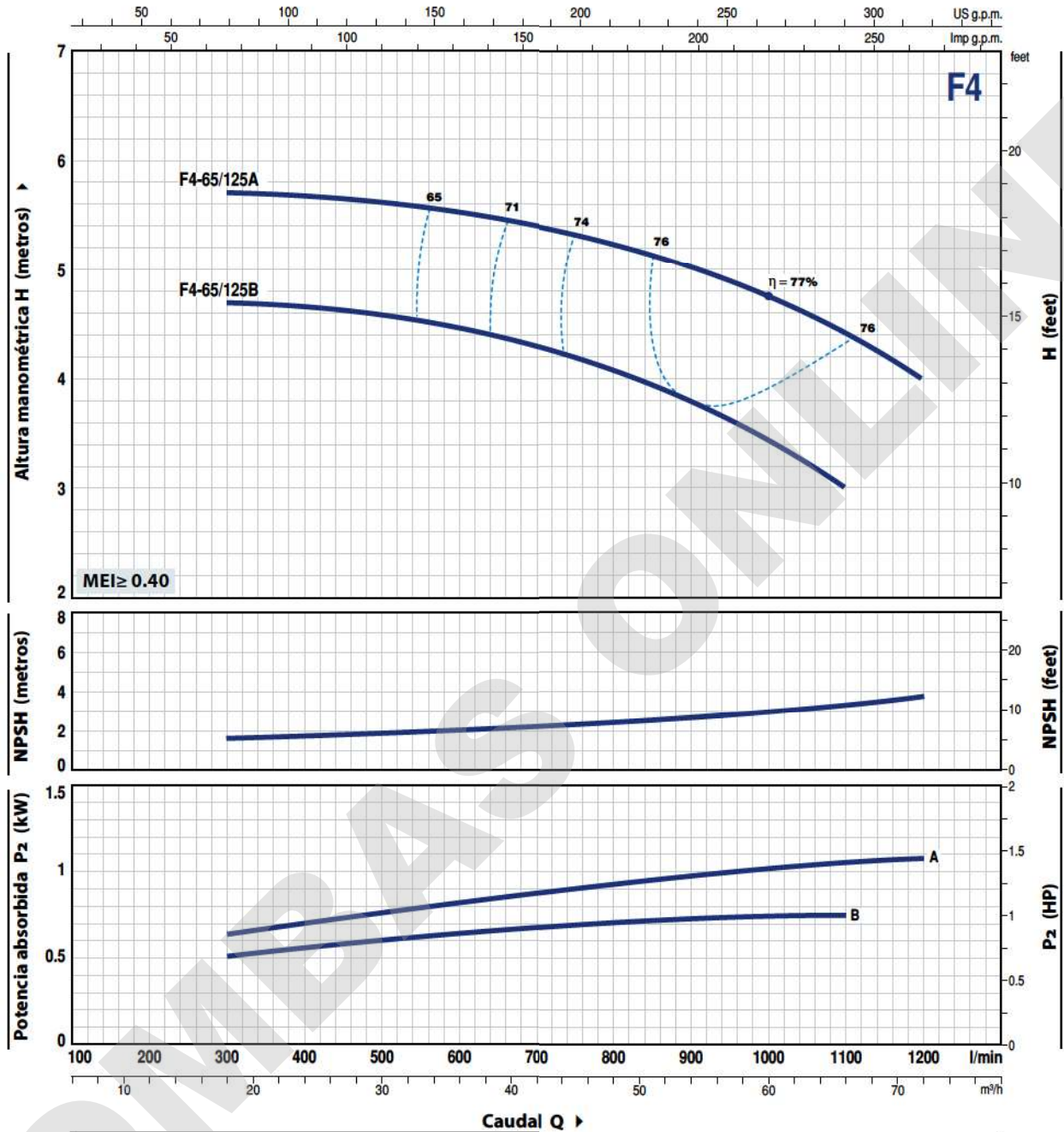

MODELO	POTENCIA (P ₂)		Q	Caudal											
	kW	HP		m ³ /h	18	24	30	36	42	48	54	60	66	72	
Trifásica			l/min	300	400	500	600	700	800	900	1000	1100	1200		
F4-65/125B	0.75	1	H metros	4.7	4.7	4.6	4.5	4.3	4.1	3.8	3.4	3			
F4-65/125A	1.1	1.5		5.7	5.7	5.6	5.5	5.4	5.2	5	4.7	4.4	4		

Q = Caudal H = Altura manométrica total HS = Altura de aspiración

Tolerancia de las curvas de prestación según EN ISO 9906 Grado 3B.

CURVAS Y DATOS DE PRESTACIONES

50 Hz n= 1450 min⁻¹ HS= 0 m

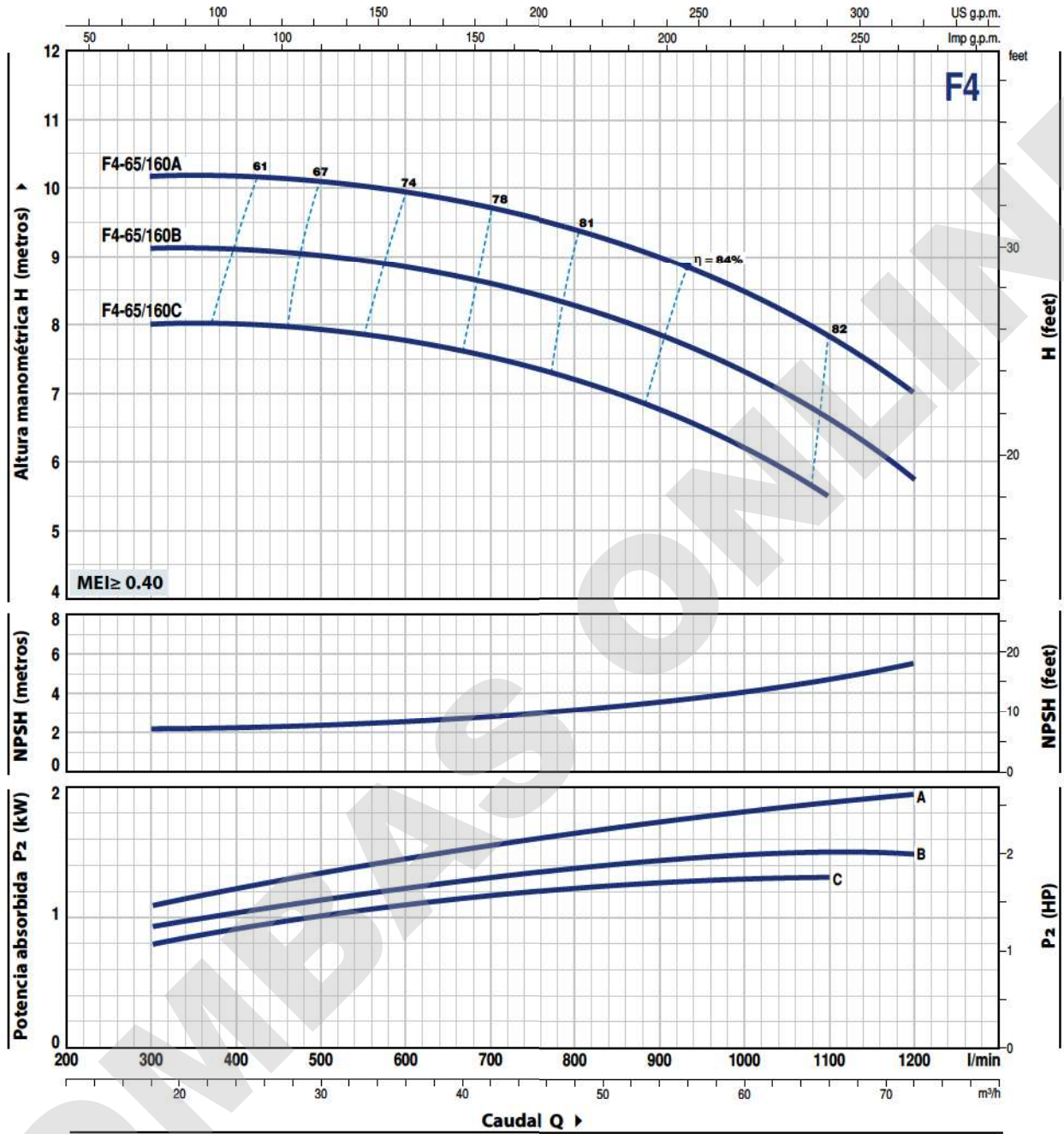

MODELO	POTENCIA (P ₂)		Q	Flow Rate (Q)												
	kW	HP		m ³ /h	18	24	30	36	42	48	54	60	66	72		
Trifásica			l/min	300	400	500	600	700	800	900	1000	1100	1200			
F4-65/160C	1.1	1.5	H metros	8	8	7.9	7.7	7.5	7.2	6.7	6.2	5.5				
F4-65/160B	1.5	2		9.1	9.1	9	8.8	8.6	8.3	7.8	7.3	6.6	5.7			
F4-65/160A	2.2	3		10.1	10.1	10.1	9.9	9.7	9.4	9	8.5	7.8	7			

Q=Caudal H=Altura manométrica total HS= Altura de aspiración

Tolerancia de las curvas de prestación según EN ISO 9906 Grado 3B.

CURVAS Y DATOS DE PRESTACIONES

50 Hz n= 1450 min⁻¹ HS= 0 m

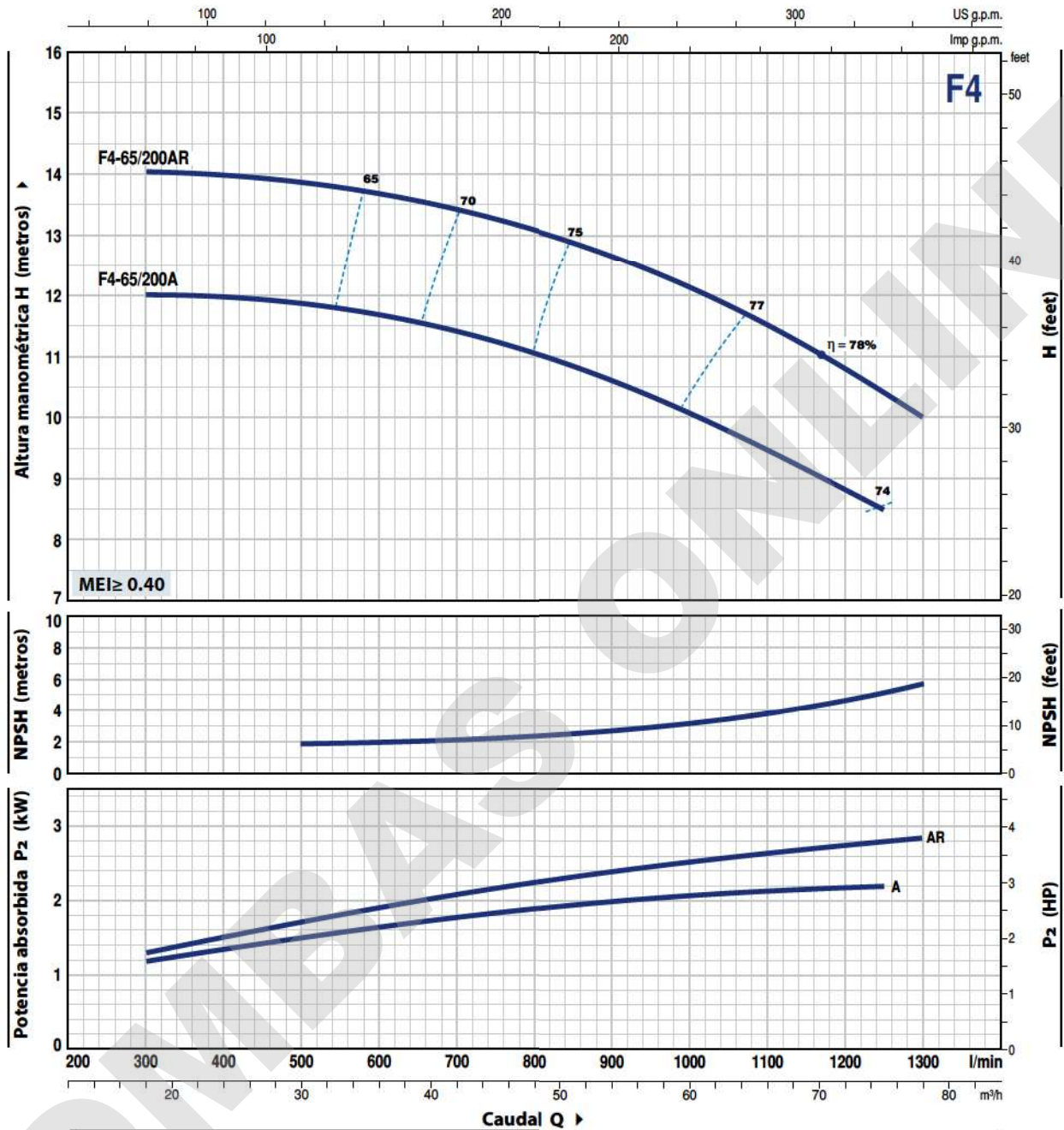

MODELO	POTENCIA (P ₂)		Q	Caudal													
	kW	HP		m ³ /h	18	24	30	36	42	48	54	60	66	72	75	78	
Trifásica			l/min	300	400	500	600	700	800	900	1000	1100	1200	1250	1300		
F4-65/200A	2.2	3	H metros	12	12	11.9	11.6	11.4	11	10.6	10.1	9.5	8.8	8.5			
F4-65/200AR	3	4		14	13.9	13.8	13.6	13.4	13.1	12.7	12.1	11.5	10.8	10.3	10		

Q = Caudal H = Altura manométrica total HS = Altura de aspiración

Tolerancia de las curvas de prestación según EN ISO 9906 Grado 3B.

CURVAS Y DATOS DE PRESTACIONES

50 Hz n= 1450 min⁻¹ HS= 0 m

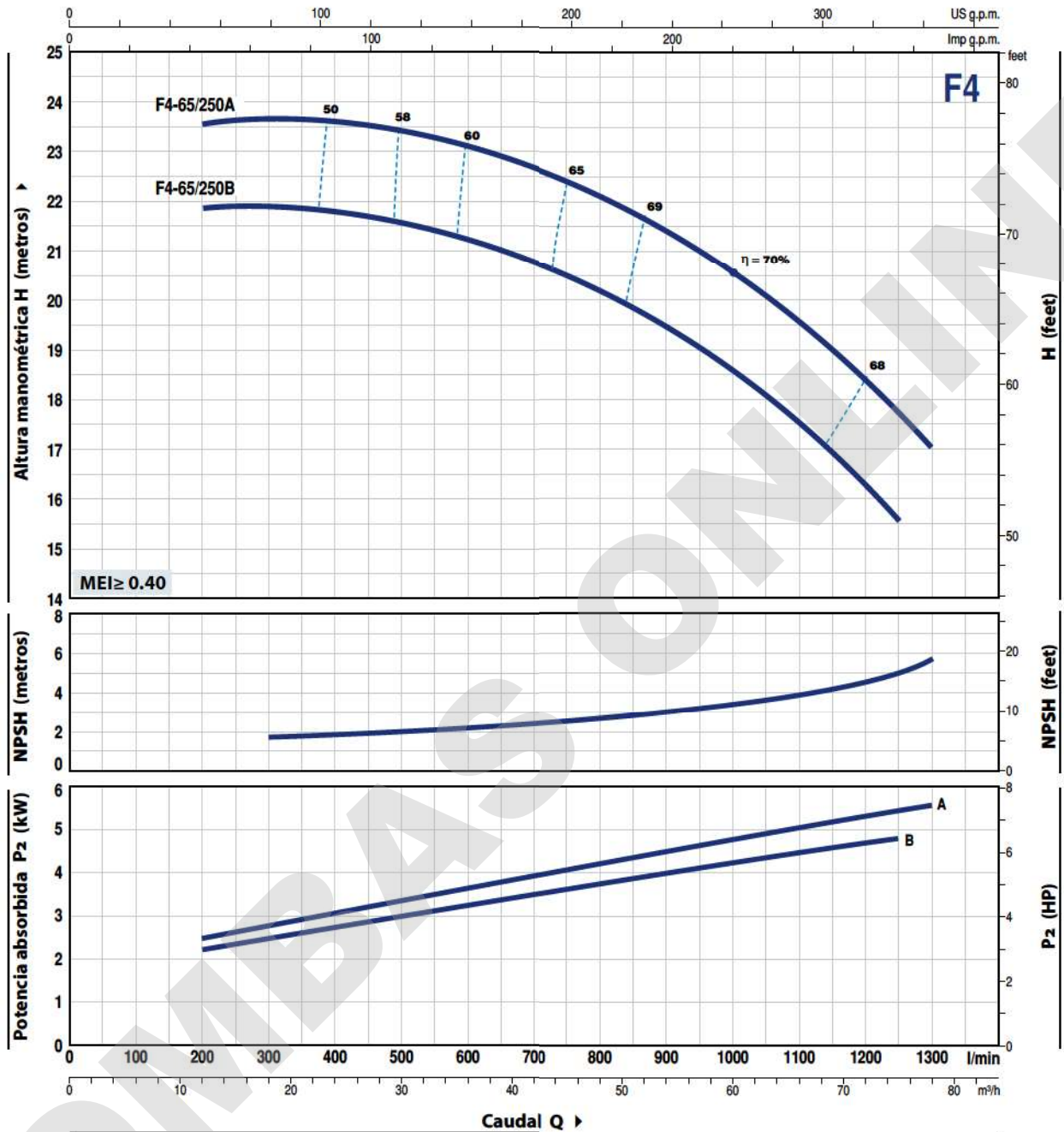

MODELO	POTENCIA (P ₂)		Q	m ³ /h														
	kW	HP		12	18	24	30	36	42	48	54	60	66	72	75	78		
Trifásica			l/min	200	300	400	500	600	700	800	900	1000	1100	1200	1250	1300		
F4-65/250B	4	5.5	H metros	21.8	21.8	21.7	21.5	21.2	20.7	20.2	19.5	18.6	17.5	16.2	15.5			
F4-65/250A	5.5	7.5		23.5	23.5	23.5	23.4	23.1	22.6	22.1	21.5	20.5	19.6	18.5	17.8	17		

Q = Caudal H = Altura manométrica total HS = Altura de aspiración

Tolerancia de las curvas de prestación según EN ISO 9906 Grado 3B.

CURVAS Y DATOS DE PRESTACIONES

50 Hz n= 1450 min⁻¹ HS= 0 m

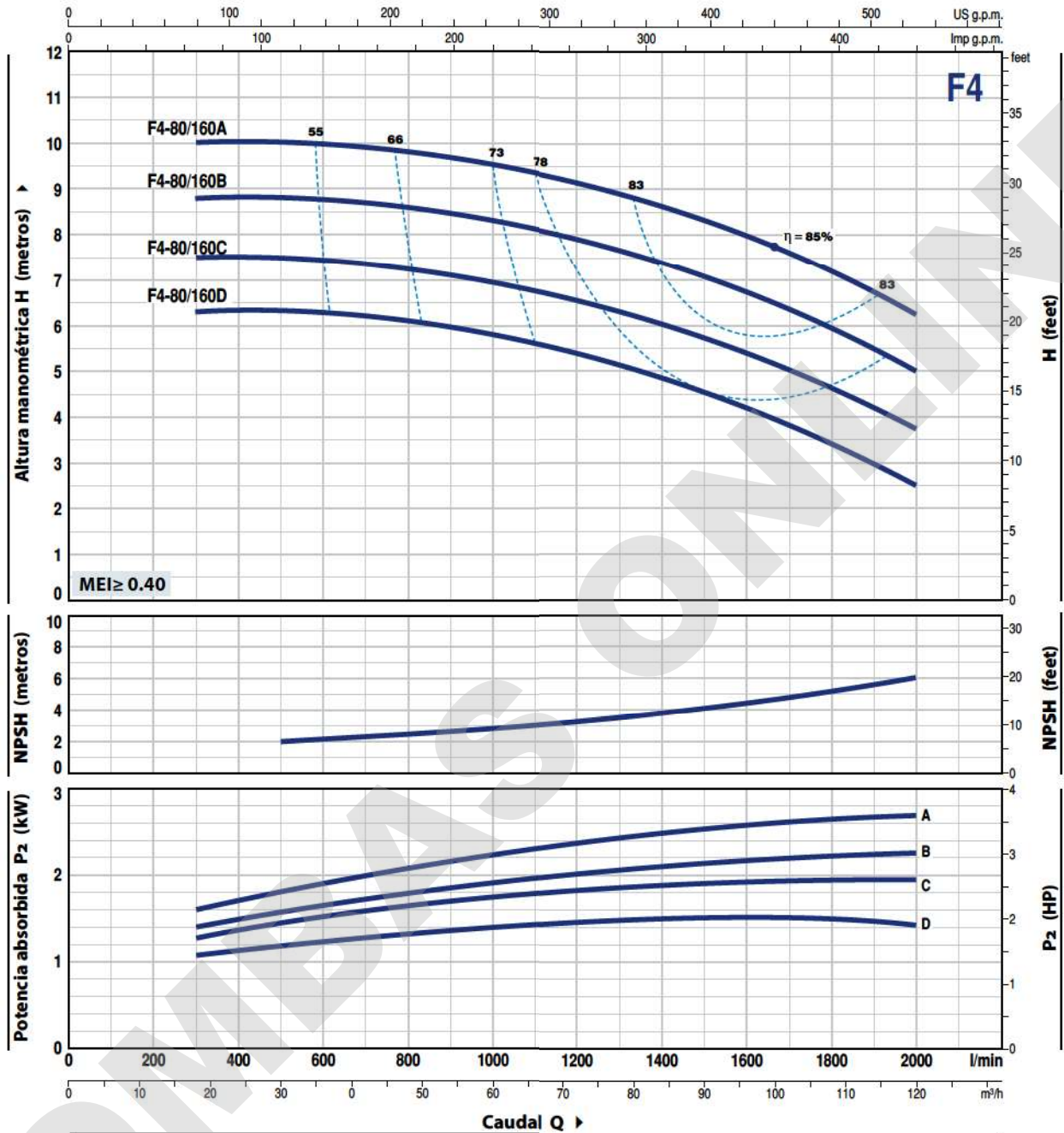

MODELO	POTENCIA (P ₂)		Q	Q											
	kW	HP		m ³ /h	18	24	36	48	60	72	84	96	108	120	
Trifásica			l/min	300	400	600	800	1000	1200	1400	1600	1800	2000		
F4-80/160D	1.5	2	H metros	6.3	6.3	6.3	6.1	5.8	5.4	4.8	4.2	3.4	2.5		
F4-80/160C	2.2	3		7.5	7.5	7.4	7.3	6.9	6.5	6	5.4	4.6	3.8		
F4-80/160B	2.2	3		8.8	8.8	8.8	8.6	8.3	7.9	7.4	6.7	5.9	5		
F4-80/160A	3	4		10	10	10	9.8	9.5	9.1	8.6	8	7.2	6.2		

Q = Caudal H = Altura manométrica total HS = Altura de aspiración

Tolerancia de las curvas de prestación según EN ISO 9906 Grado 3B.

CURVAS Y DATOS DE PRESTACIONES

50 Hz n = 1450 min⁻¹ HS = 0 m

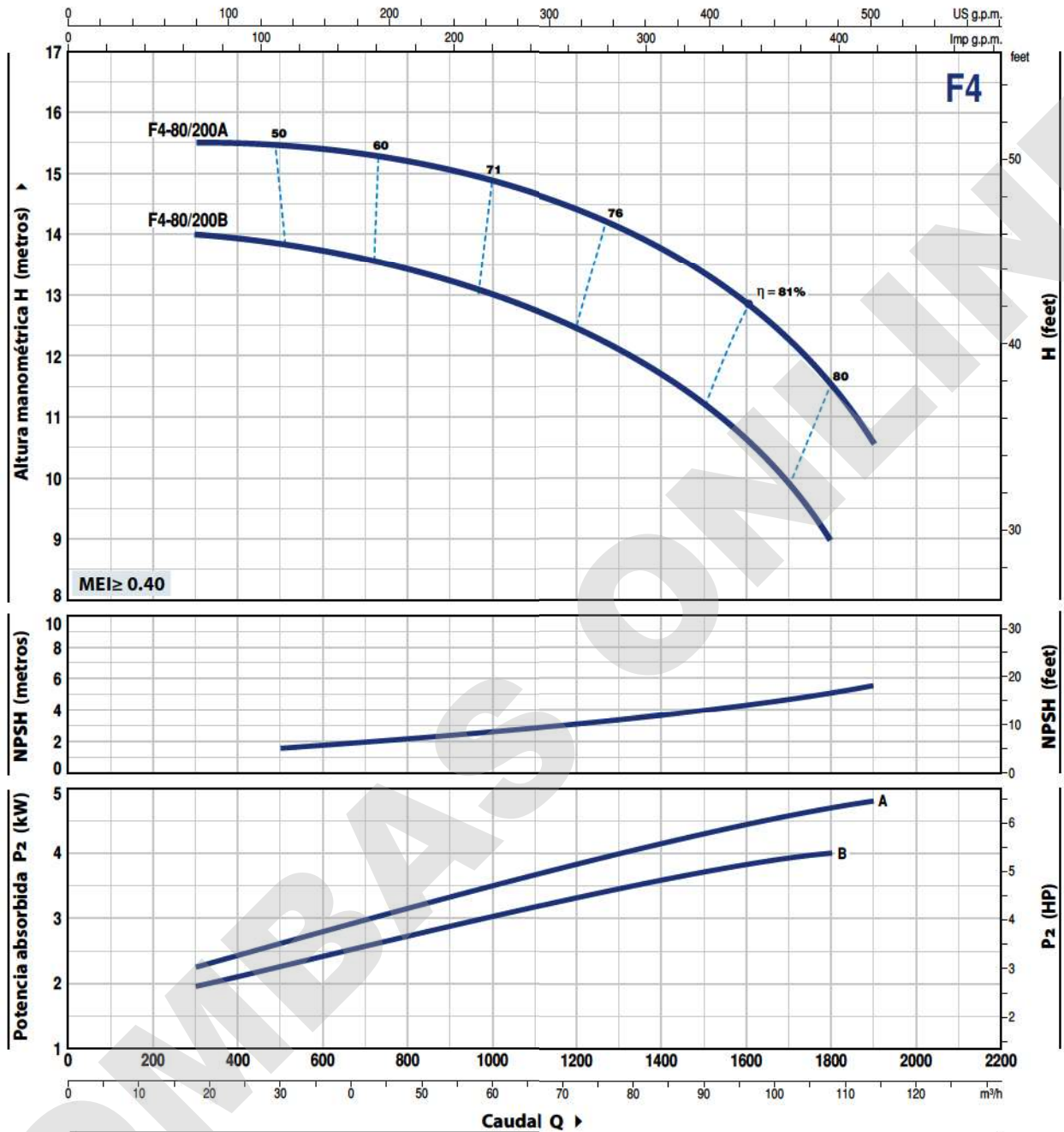

MODELO	POTENCIA (P ₂)		Q	Flow Rate (Q)											
	kW	HP		m ³ /h	l/min	18	24	36	48	60	72	84	96	108	114
Trifásica				300	400	600	800	1000	1200	1400	1600	1800	1900		
F4-80/200B	4	5.5	H metros		14	13.9	13.7	13.4	13	12.5	11.7	10.6	9		
F4-80/200A	5.5	7.5			15.5	15.5	15.4	15.2	14.8	14.5	13.7	12.8	11.5	10.5	

Q = Caudal H = Altura manométrica total HS = Altura de aspiración

Tolerancia de las curvas de prestación según EN ISO 9906 Grado 3B.

CURVAS Y DATOS DE PRESTACIONES

50 Hz n= 1450 min⁻¹ HS= 0 m

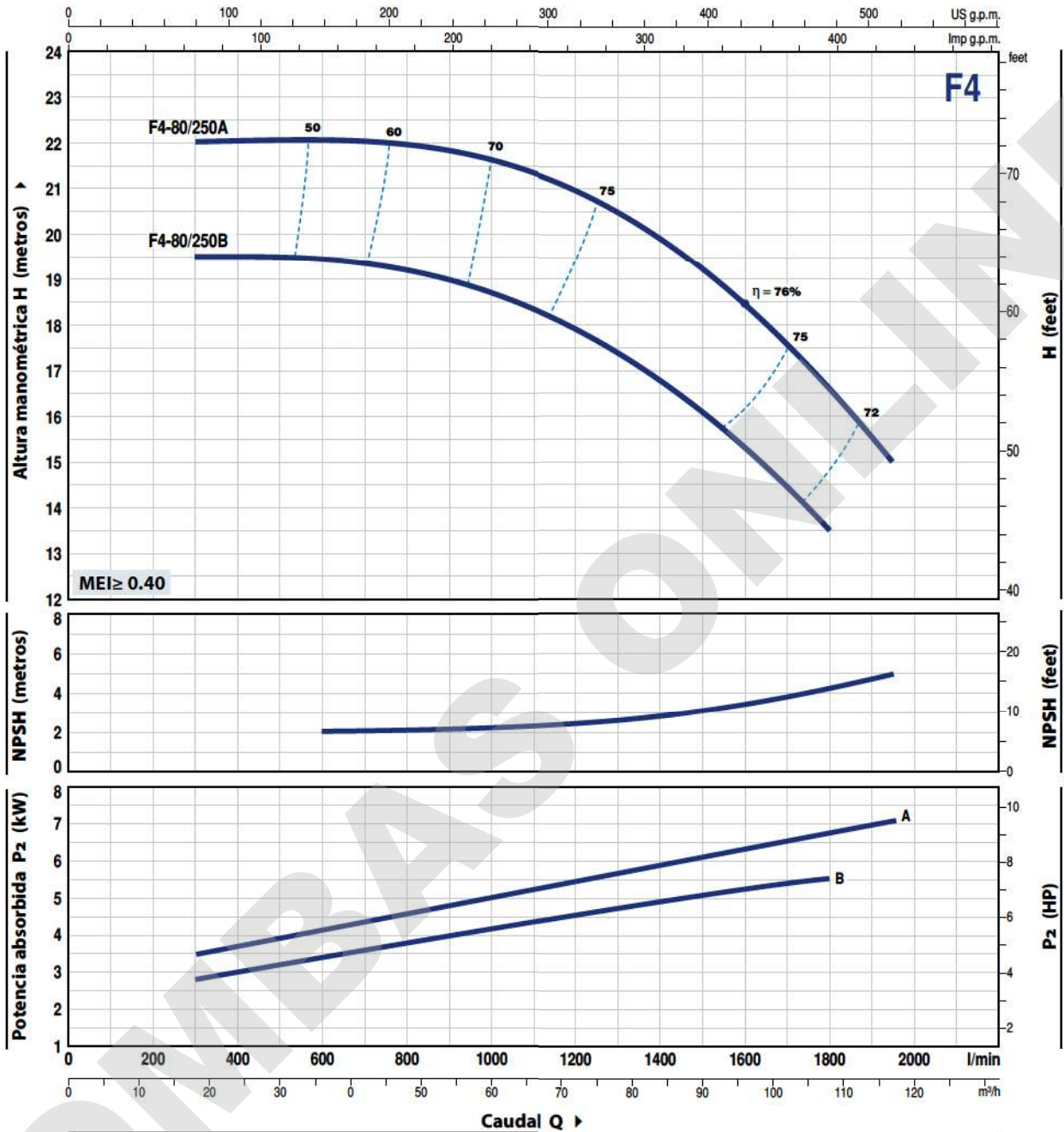

MODELO	POTENCIA (P ₂)		Q	Flow Rate (Q)												
	kW	HP		m ³ /h	18	24	36	48	60	72	84	96	108	117		
Trifásica			l/min	300	400	600	800	1000	1200	1400	1600	1800	1950			
F4-80/250B	5.5	7.5	H metros	19.5	19.5	19.5	19.2	18.7	17.9	16.7	15.3	13.5				
F4-80/250A	7.5	10		22	22	22	21.9	21.6	21	20	18.5	16.5	15			

Q = Caudal H = Altura manométrica total HS = Altura de aspiración

Tolerancia de las curvas de prestación según EN ISO 9906 Grado 3B.

CURVAS Y DATOS DE PRESTACIONES

50 Hz n= 1450 min⁻¹ HS= 0 m

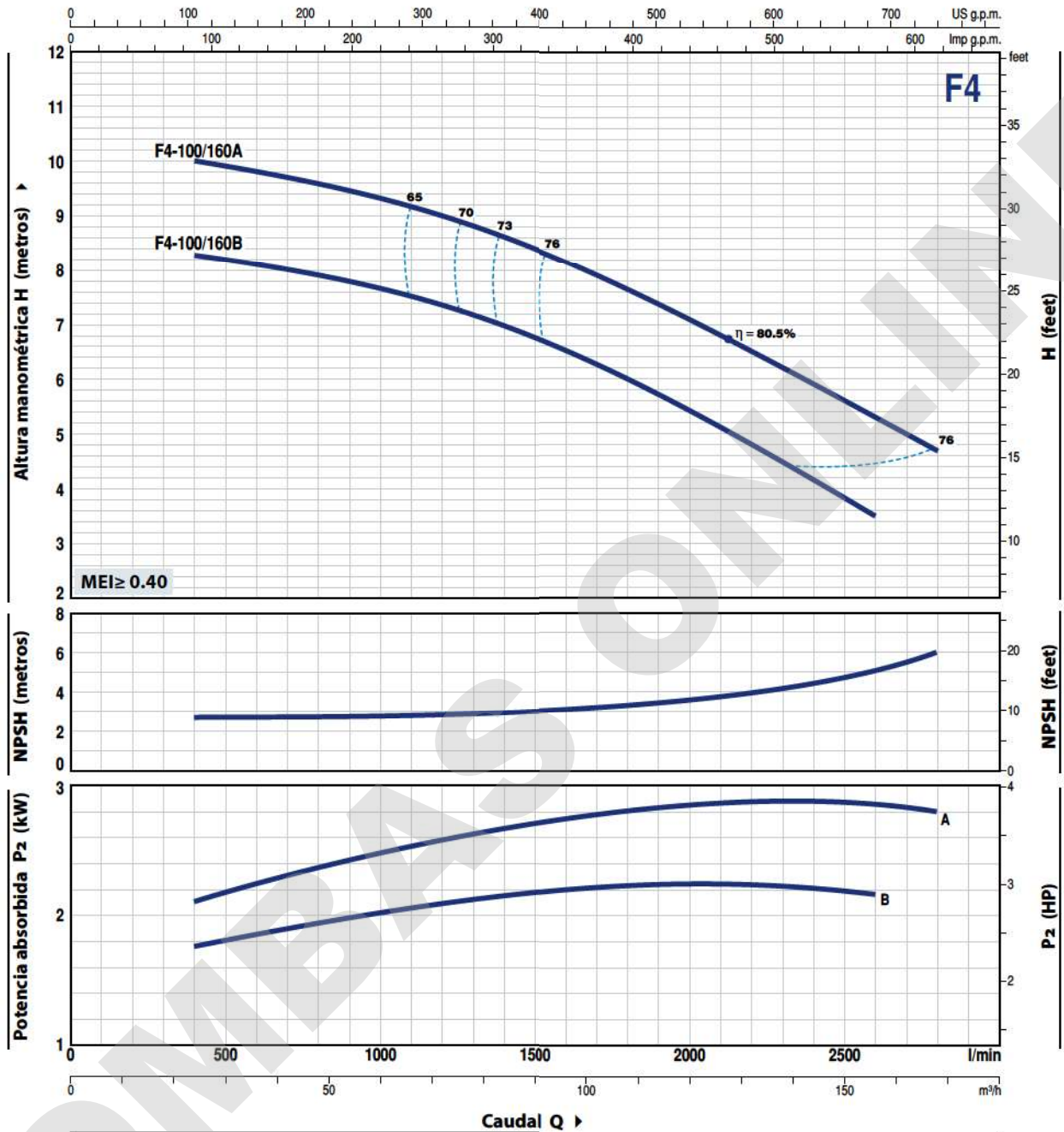

MODELO	POTENCIA (P ₂)		Q	Q										
	kW	HP		m ³ /h	24	48	72	96	120	144	156	168		
Trifásica			l/min	400	800	1200	1600	2000	2400	2600	2800			
F4-100/160B	2.2	3	H metros	8.3	8	7.5	6.5	5.5	4.2	3.5				
F4-100/160A	3	4		10	9.5	9	8	7	6	5.2	4.7			

Q = Caudal H = Altura manométrica total HS = Altura de aspiración

Tolerancia de las curvas de prestación según EN ISO 9906 Grado 3B.

CURVAS Y DATOS DE PRESTACIONES

50 Hz n= 1450 min⁻¹ HS= 0 m

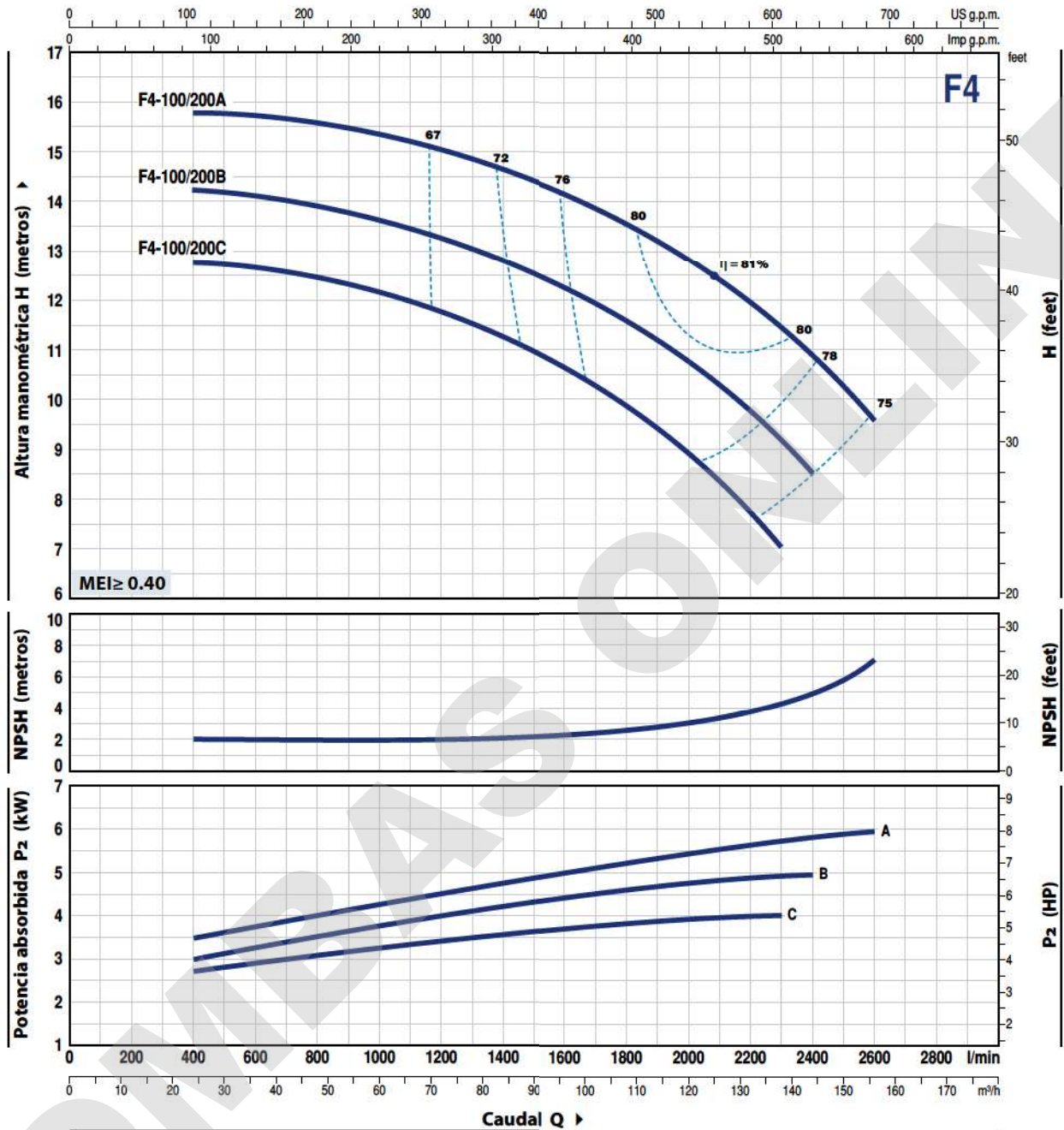

MODELO	POTENCIA (P ₂)		Q	Flow Rate (Q)														
	kW	HP		m ³ /h	24	36	48	60	72	84	96	108	120	138	144	156		
Trifásica			l/min	400	600	800	1000	1200	1400	1600	1800	2000	2300	2400	2600			
F4-100/200C	4	5.5	H metros	12.7	12.6	12.5	12.2	11.8	11.3	10.6	9.9	8.9	7					
F4-100/200B	5.5	7.5		14.2	14.1	13.9	13.6	13.3	12.8	12.2	11.6	10.7	9.2	8.5				
F4-100/200A	5.5	7.5		15.8	15.7	15.6	15.4	15	14.6	14.2	13.5	12.8	12	11.4	9.5			

Q=Caudal H=Altura manométrica total HS= Altura de aspiración

Tolerancia de las curvas de prestación según EN ISO 9906 Grado 3B.

CURVAS Y DATOS DE PRESTACIONES

50 Hz n= 1450 min⁻¹ HS= 0 m

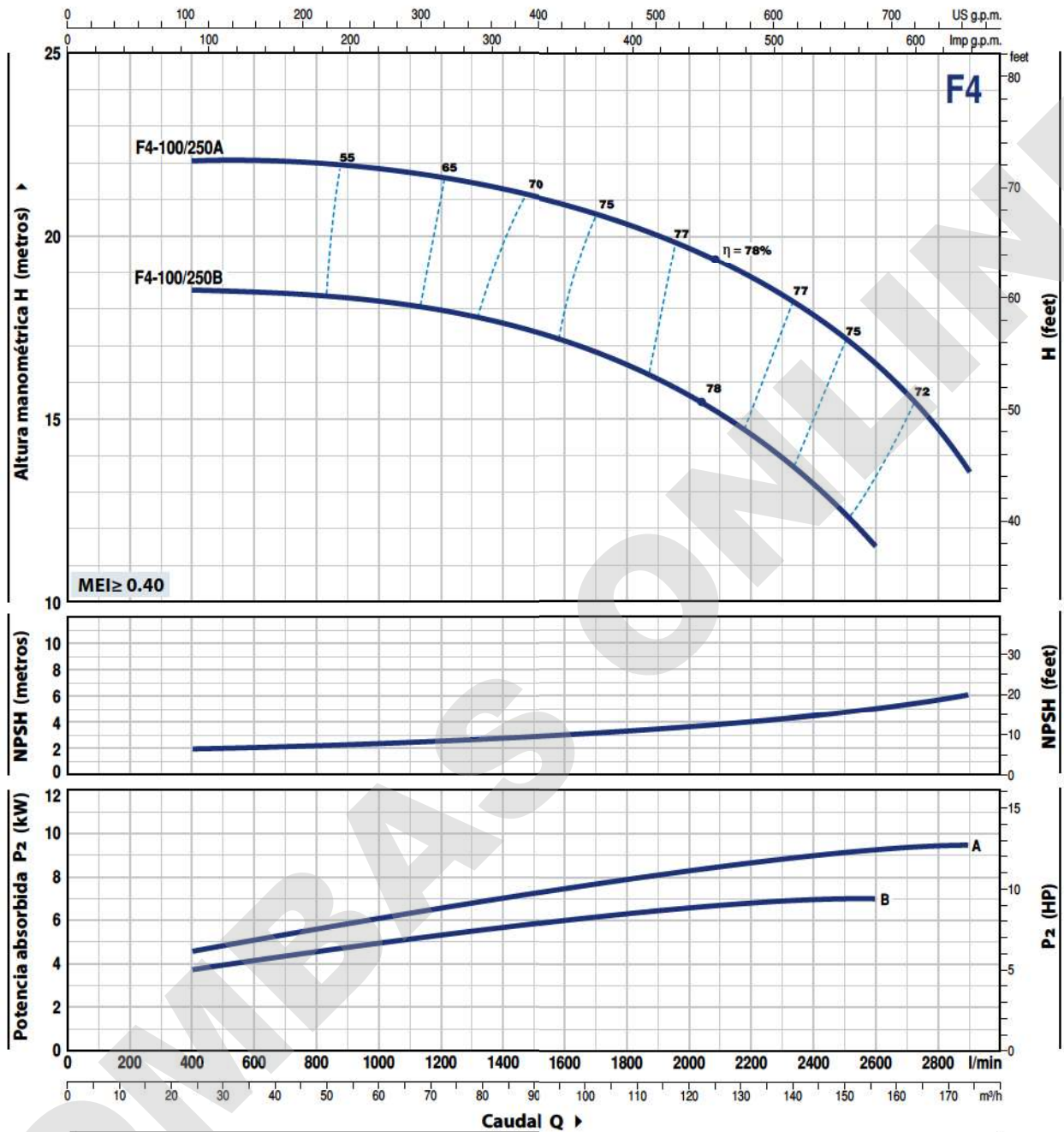

MODELO	POTENCIA (P ₂)		Q	Caudal													
	kW	HP		m ³ /h	24	36	48	60	72	84	96	108	120	132	144	156	174
Trifásica			l/min	400	600	800	1000	1200	1400	1600	1800	2000	2200	2400	2600	2900	
F4-100/250B	7.5	10	H metros	18.5	18.5	18.3	18.2	18	17.5	17.1	16.5	15.7	14.5	13.2	11.5		
F4-100/250A	9.2	12.5		22	22	22	21.8	21.6	21.2	20.9	20.3	19.7	18.9	17.9	16.5	13.5	

Q = Caudal H = Altura manométrica total HS = Altura de aspiración

Tolerancia de las curvas de prestación según EN ISO 9906 Grado 3B.

POS. COMPONENTE CARACTERISTICAS CONSTRUCTIVAS

1 CUERPO BOMBA	Hierro fundido con bocas de aspiración e impulsión con bridas					
2 TAPA	Hierro fundido					
3 RODETE	Latón para F4-32/160, 32/200, 40/160, 40/200, 50/125, 50/160					
4 EJE MOTOR	Acero inoxidable AISI 431					
5 SELLO MECANICO	Electrobomba	Sello	Eje	Materiales		
	<i>Modelo</i>	<i>Modelo</i>	<i>Diámetro</i>	<i>Anillo fijo</i>	<i>Anillo móvil</i>	<i>Elastómero</i>
	F4-32/160 F4-50/125	FN-20	Ø 20 mm	Grafito	Cerámica	NBR
	F4-40/160					
	F4-32/200 F4-50/160	FN-24	Ø 24 mm	Grafito	Cerámica	NBR
	F4-40/200 F4-65/125					
	F4-50/200 F4-80/160	FN-32 NU	Ø 32 mm	Grafito	Cerámica	NBR
	F4-65/200 F4-100/160					
	F4-65/160					
	F4-32/250 F4-50/250	FN-38	Ø 38 mm	Grafito	Cerámica	NBR
	F4-40/250					
	F4-65/250 F4-100/200	FN-40 NU	Ø 40 mm	Grafito	Cerámica	NBR
	F4-80/200					
	F4-80/250 F4-100/250	FH-45 NU	Ø 45 mm	Grafito	Cerámica	NBR
6 RODAMIENTOS	Electrobomba	Modelo	Electrobomba		Modelo	
			F4-32/250			
	F4-32/160	6206 ZZ-C3 / 6204 ZZ	F4-40/250			
	F4-40/160		F4-50/200			
	F4-50/125		F4-50/250		6208 ZZ-C3 / 6206 ZZ-C3	
			F4-65/160			
	F4-32/200	6307 ZZ-C3 / 6206 ZZ-C3	F4-65/200			
	F4-40/200		F4-80/160			
	F4-50/160		F4-100/160			
	F4-65/125		F4-65/250			
			F4-80/200			
			F4-80/250		6310 ZZ-C3 / 6308 ZZ-C3	
			F4-100/200			
			F4-100/250			
7 MOTOR ELECTRICO	F4: a 4 polos trifásica 230/400 V - 50 Hz					
	→ Las electrobombas están equipadas con motores de alto rendimiento en clase IE2 hasta P ₂ =0.37 kW y en clase IE3 desde P ₂ =0.75 kW (IEC 60034-30-1)					
	- Aislamiento: clase F					
	- Protección: IP 55					

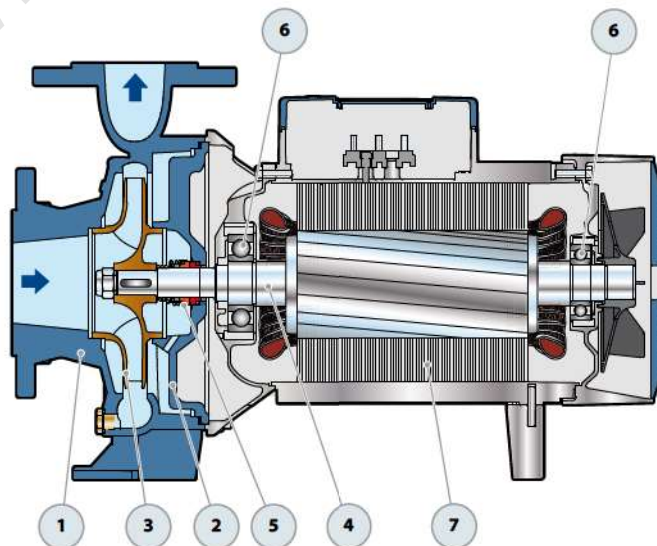

DIMENSIONES Y PESOS

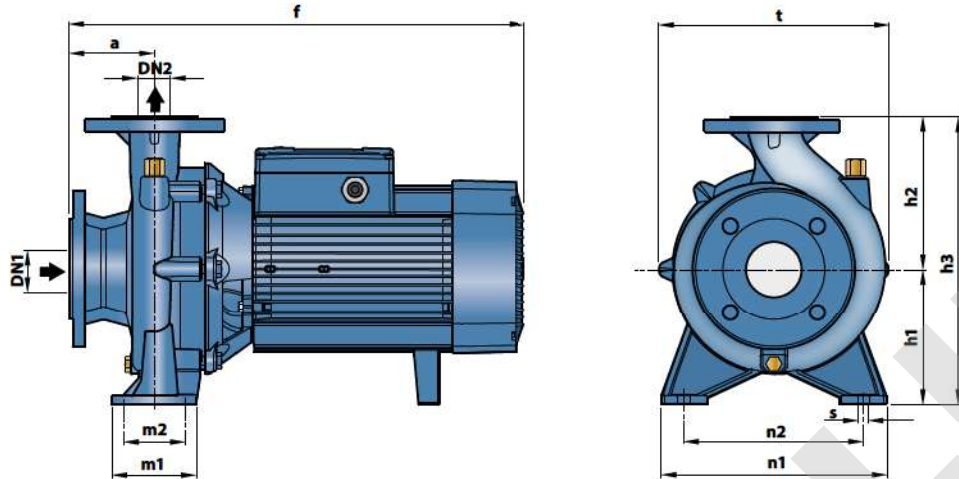

MODELO	DIMENSIONES mm													kg							
	DN1	DN2	a	f	h3	h1	h2	t	n2	n1	m1	m2	s								
Trifásica																					
F4-32/160B	50	32	80	412	292	132	160	242	190	240	95	70	14	31.2							
F4-32/160A				469	340	160	180	270						42.3							
F4-32/200B				522	405	180	225	330						250	320	125	95	64.1			
F4-32/200A				568	68.7																
F4-32/250B			100	40	80	412	292	132	160	240	190	240		100	70	14	32.5				
F4-32/250A						489	340	160	180	275							212	265	46.0		
F4-40/160B						522	405	180	225	328							250	320	125	95	60.1
F4-40/160A						568	72.4														
F4-40/200B	100	50	80	431	292	132	160	242	190	240	100	70	14	32.2							
F4-40/200A				489	340	160	180	269						212	265		125	95	44.4		
F4-40/250C				529	360	160	200	316											59.2		
F4-40/250B				576	68.3																
F4-40/250A	522	68.5																			
F4-40/250AR	568	78.0																			
F4-50/125B	65	65	100	511	340	160	180	291	212	280	125	95		14	50.2						
F4-50/125A				533	360	200	300	50.4													
F4-50/160C				579	58.7																
F4-50/160B				582	65.0																
F4-50/200C			125	80	100	582	405	180	225	340	250	320	160		120	18	72.0				
F4-50/200B						627	450	200	250	373							280	360	111.2		
F4-50/200A						627	139.6														
F4-50/200AR						565	65.8														
F4-50/250B	125	80	125	565	405	180	225	330	250	320	125	95	14	67.3							
F4-50/250A				611	430	250	360	280						345	70.0						
F4-80/160D				655	76.4																
F4-80/160C				673	100.0																
F4-80/160B	100	80	125	655	430	200	280	405	315	400	160	120		18	130.2						
F4-80/160A				673	480	200	280	405							315	400	149.5				
F4-80/200B				673	137.6																
F4-80/200A				622	91.0																
F4-80/250B	125	100	125	622	480	200	280	362	280	360	160	120	18		97.0						
F4-80/250A				657	122.0																
F4-100/160B				694	116.0																
F4-100/160A				789	124.1																
F4-100/200C	140	100	125	694	505	225	280	422	315	400	160	120		18	143.0						
F4-100/200B				789	159.3																
F4-100/200A																					
F4-100/250B																					
F4-100/250A																					

BRIDAS DE LAS BOCAS

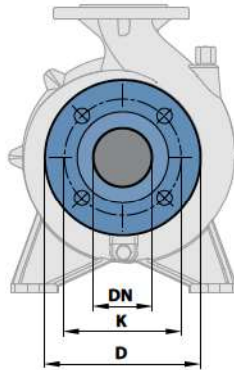

DN BRIDAS	D	K	ORIFICIOS	
			N°	Ø (mm)
32	140	100	4	18
40	150	110		
50	165	125		
65	185	145		
80	200	160		
100	220	180	8	
125	250	210		

CONTOBRIDAS

(SE PUEDE PEDIR A PARTE)

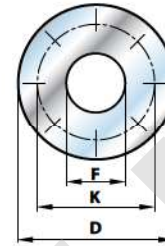

DN BRIDAS	F	D	K	ORIFICIOS	
				N°	Ø (mm)
32	1¼"	140	100	4	18
40	1½"	150	110		
50	2"	165	125		
65	2½"	185	145		
80	3"	200	160		
100	4"	220	180	8	
125	5"	250	210		

CONSUMO EN AMPERIOS

MODELO	TENSION	
	230-240 V	400-415 V
Trifásica		
F4-32/160B	1.9 A	1.1 A
F4-32/160A	1.9 A	1.3 A
F4-32/200B	3.6 A	2.1 A
F4-32/200A	4.0 A	2.3 A
F4-32/200BH	3.3 A	1.9 A
F4-32/200AH	3.5 A	2.0 A
F4-32/250C	5.7 A	2.6 A
F4-32/250B	7.3 A	3.3 A
F4-32/250A	7.8 A	5.2 A
F4-40/160B	2.1 A	1.2 A
F4-40/160A	2.8 A	1.6 A
F4-40/200B	3.6 A	2.1 A
F4-40/200A	4.2 A	2.4 A
F4-40/250C	5.5 A	2.6 A
F4-40/250B	6.1 A	3.5 A
F4-40/250A	8.5 A	5.2 A
F4-50/125B	2.3 A	1.4 A
F4-50/125A	2.6 A	1.5 A
F4-50/160B	3.3 A	2.1 A
F4-50/160A	4.2 A	2.4 A
F4-50/200C	6.1 A	3.5 A
F4-50/200B	8.0 A	4.6 A
F4-50/200A	9.0 A	5.2 A
F4-50/200AR	10.6 A	6.8 A
F4-50/250D	4.9 A	2.8 A
F4-50/250C	5.9 A	3.4 A
F4-50/250B	8.5 A	4.9 A
F4-50/250A	9.9 A	5.7 A
F4-50/250AR	11.8 A	6.8 A

MODELO	TENSION	
	230-240 V	400-415 V
Trifásica		
F4-65/125B	3.6 A	2.1 A
F4-65/125A	4.5 A	2.6 A
F4-65/160C	5.2 A	2.7 A
F4-65/160B	5.9 A	3.4 A
F4-65/160A	7.8 A	4.5 A
F4-65/200A	9.0 A	5.2 A
F4-65/200AR	11.8 A	6.8 A
F4-65/250B	17.3 A	9.5 A
F4-65/250A	21.7 A	13.5 A
F4-80/160D	5.9 A	3.4 A
F4-80/160C	8.1 A	4.7 A
F4-80/160B	9.2 A	5.3 A
F4-80/160A	10.6 A	6.8 A
F4-80/200B	13.8 A	9.5 A
F4-80/200A	18.2 A	12.8 A
F4-80/250B	20.8 A	13.5 A
F4-80/250A	25.6 A	14.8 A
F4-100/160B	9.0 A	5.2 A
F4-100/160A	11.2 A	6.5 A
F4-100/200C	14.2 A	9.5 A
F4-100/200B	17.8 A	12.1 A
F4-100/200A	20.8 A	13.5 A
F4-100/250B	26.8 A	15.9 A
F4-100/250A	34.1 A	19.7 A