

50 Hz



## e-SV™ Series

1, 3, 5, 10, 15, 22

33, 46, 66, 92, 125

VERTICAL MULTISTAGE ELECTRIC PUMPS  
EQUIPPED WITH **IE3** MOTORS

ErP 2009/125/EC

**66SV SERIES**  
**DIMENSIONS AND WEIGHTS AT 50 Hz, 2 POLES**

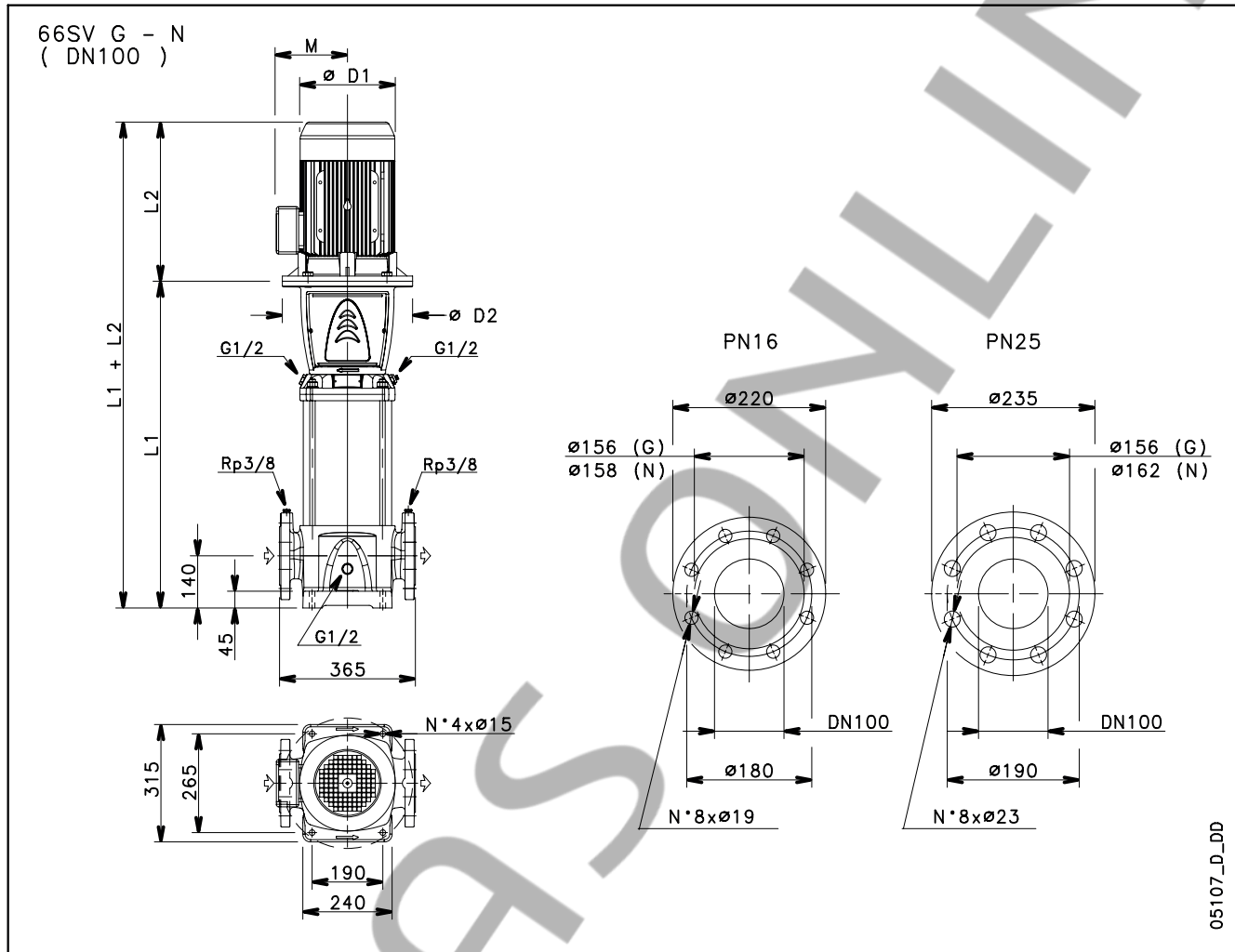

PUMP TYPE	MOTOR		DIMENSIONS (mm)							WEIGHT kg	
	kW	SIZE	L1	L2	D1	D2	M	PN	PUMP	ELECTRIC PUMP	
66SV1/1A../D	4	112	554	319	197	164	154	16	66	92,5	
66SV1../D	5,5	132	574	375	214	300	168	16	72	110	
66SV2/2A../D	7,5	132	664	367	256	300	191	16	77	133	
66SV2/1A../D	11	160	699	428	256	350	191	16	81	151	
66SV2../D	11	160	699	428	256	350	191	16	81	151	
66SV3/2A../D	15	160	789	494	313	350	240	16	86	188	
66SV3/1A../D	15	160	789	494	313	350	240	16	86	188	
66SV3../D	18,5	160	789	494	313	350	240	16	86	197	
66SV4/2A../D	18,5	160	879	494	313	350	240	16	92	203	
66SV4/1A../D	22	180	879	494	313	350	240	16	93	214	
66SV4../D	22	180	879	494	313	350	240	16	93	214	
66SV5/2A../D	30	200	969	657	402	400	317	16	105	320	
66SV5/1A../D	30	200	969	657	402	400	317	16	105	320	
66SV5../D	30	200	969	657	402	400	317	16	105	320	
66SV6/2A../D	30	200	1059	657	402	400	317	25	113	328	
66SV6/1A../D	30	200	1059	657	402	400	317	25	113	328	
66SV6../D	37	200	1059	657	402	400	317	25	113	343	
66SV7/2A../D	37	200	1149	657	402	400	317	25	118	348	
66SV7/1A../D	37	200	1149	657	402	400	317	25	118	348	

PUMP TYPE	MOTOR		DIMENSIONS (mm)							WEIGHT kg	
	kW	SIZE	L1	L2	D1	D2	M	PN	PUMP	ELECTRIC PUMP	
66SV7../D	45	225	1149	746	455	450	384	25	122	478	
66SV8/2A../D	45	225	1239	746	455	450	384	25	127	483	
66SV8/1A../D	45	225	1239	746	455	450	384	25	127	483	
66SV8../D	45	225	1239	746	455	450	384	25	127	483	

66sv-2p50-en\_b\_td



**66SV SERIES**  
**OPERATING CHARACTERISTICS AT 50 Hz, 2 POLES**

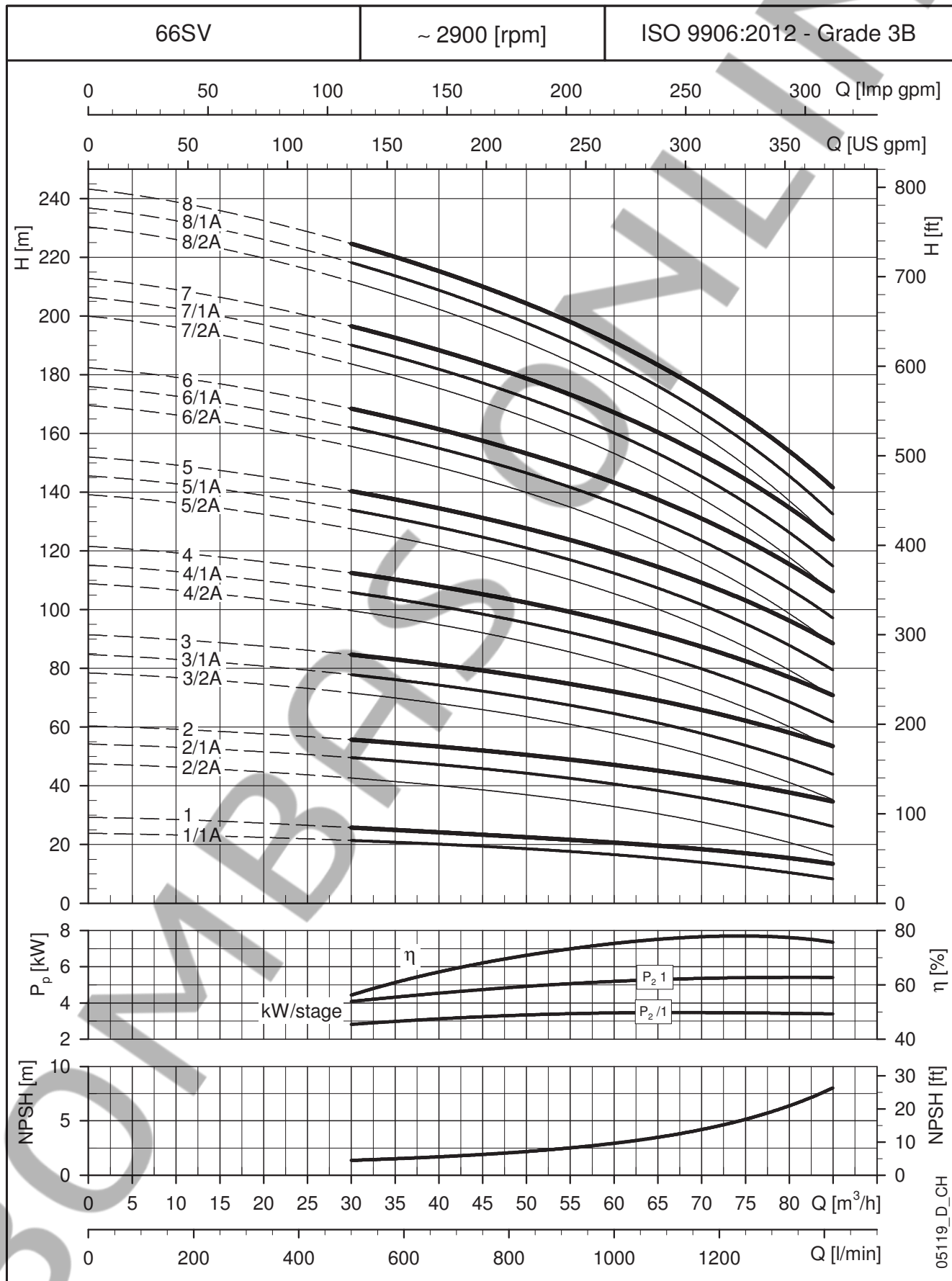

These performances are valid for liquids with density  $\rho = 1.0 \text{ Kg/dm}^3$  and kinematic viscosity  $\nu = 1 \text{ mm}^2/\text{sec}$ .