

**50 Hz**



# DOC - DIWA - DOMO DOMO GRI - DN - DL Series

DRAINAGE AND SEWAGE  
ELECTRIC PUMPS

## Submersible Electric Pumps for drainage of dirty water

The DOMO series electric pumps are available with **twin-channel** or **vortex** impeller (DOMO VX). Designed to handle liquids with suspended solids up to 50 mm in diameter (35 mm for DOMO 7 and DOMO 7VX).

Four basic models with 0,55 to 1,5 kW.

### DRIVELUB SEAL SYSTEM.

## DOMO Series



### APPLICATIONS

- Pumping of effluent (VX model handles also suspended filaments).
- Emptying of septic tanks and residential sumps.
- Draining of flooded basements and garages.

### SPECIFICATIONS

- **Maximum liquid temperature:** 35°C with fully submerged pump.
- **Dry motor.**
- **Power cord: H07RN-F**
  - single-phase: with plug.
  - three-phase: without plug.
- **Insulation class 155°C (F).**
- **IPX8 protection.**
- **Maximum immersion depth: 5 m.**
- **Versions:**
  - Single-phase: 220-240V, 50Hz 2 poles.
  - Three-phase: 220-240V, 50Hz 2 poles. 380-415V, 50Hz 2 poles.
- **Motor power:**
  - single-phase: **0,55 to 1,1 kW.**
  - three-phase: **0,55 to 1,5 kW.**

- **The single-phase versions** feature:
  - **pre-assembled float switch** for automatic pump operation.
  - **built-in capacitor.**
  - **thermal overload protection** to stop pump supply in case of overheating.

- **built-in capacitor.**
- **thermal overload protection** to stop pump supply in case of overheating.

- The **DOMO 7** and **DOMO 7VX** models feature:

- **Rp 1 1/2" threaded delivery port** (female gas).
- handling of liquids with suspended **solids up to 35 mm** in diameter.
- **fiberglass-reinforced technopolymer impeller** (DOMO S7 and DOMO S7VX models with stainless steel impeller are also available).

- The **DOMO 10-15-20** and **DOMO 10-15-20 VX** models feature:

- **Rp 2" threaded delivery port** female gas (can be turned into a flanged version if an optional accessory is installed).
- handling of liquids with suspended **solids up to 50 mm** in diameter.
- **stainless steel twin-channel or vortex impeller.**

### DRIVELUB SEAL SYSTEM

- Watertight electric motor protected by multiple seal system with **oil chamber**. A **V-ring** and **silicon carbide mechanical seal** (extremely resistant to wear and abrasion), as well as a **lip seal** which is continuously lubricated by the **DRIVELUB system**, provide an extreme barrier against infiltration.

**DOMO VX SERIES  
OPERATING CHARACTERISTICS AT 50 Hz**

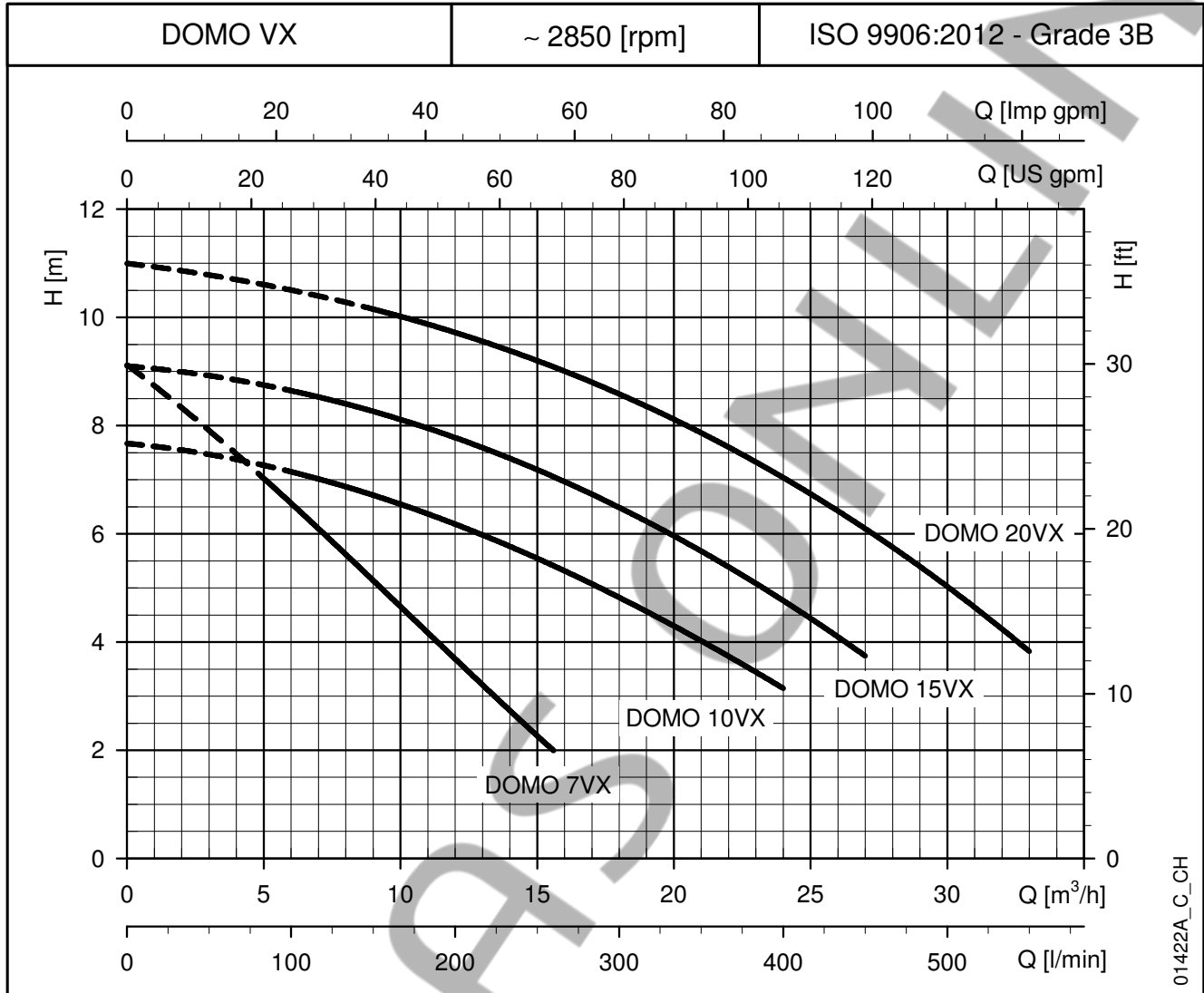

**HYDRAULIC PERFORMANCE TABLE**

PUMP TYPE	RATED POWER		Q = DELIVERY												
			H = TOTAL HEAD METRES COLUMN OF WATER												
			l/min	80	100	150	175	200	225	260	300	400	450	550	
	kW	HP	m³/h	0	4,8	6	9	10,5	12	13,5	15,6	18	24	27	33
DOMO 7VX(T) - S7VX(T)	0,55	0,75	9,1	7,1	6,6	5,1	4,4	3,7	3,0	2,0					
DOMO 10VX(T)	0,75	1	7,7	7,3	7,1	6,7	6,5	6,2	5,9	5,4	4,8	3,1			
DOMO 15VX(T)	1,1	1,5	9,1	8,8	8,6	8,3	8,0	7,8	7,5	7,1	6,5	4,8	3,7		
DOMO 20VXT	1,5	2	11,0	10,6	10,5	10,2	9,9	9,7	9,5	9,1	8,6	7,0	6,1	3,8	

These performances are valid for liquids with density  $\rho = 1,0 \text{ kg/dm}^3$  and kinematic viscosity  $\nu = 1 \text{ mm}^2/\text{s}$ .

domovx-2p50-en\_b\_th

**ELECTRICAL DATA TABLE**

PUMP TYPE	ABSORBED POWER*	ABSORBED CURRENT*	CAPACITOR	PUMP TYPE	ABSORBED POWER*	ABSORBED CURRENT*	ABSORBED CURRENT*
	kW	A	$\mu\text{F} / 450 \text{ V}$		THREE-PHASE	kW	A
DOMO 7VX - (S7VX)	0,79 (0,83)	3,91 (4,03)	16	DOMO 7VXT - (S7VXT)	0,71 (0,76)	2,56 (2,63)	1,48 (1,52)
DOMO 10VX	1,15	5,88	22	DOMO 10VXT	1,10	4,09	2,36
DOMO 15VX	1,36	6,11	30	DOMO 15VXT	1,26	4,31	2,49
-	-	-	-	DOMO 20VXT	1,74	6,22	3,59

\*Maximum values within operating range

domovx-2p50-en\_b\_te

**DOMO SERIES**  
**DIMENSIONS AND WEIGHTS**

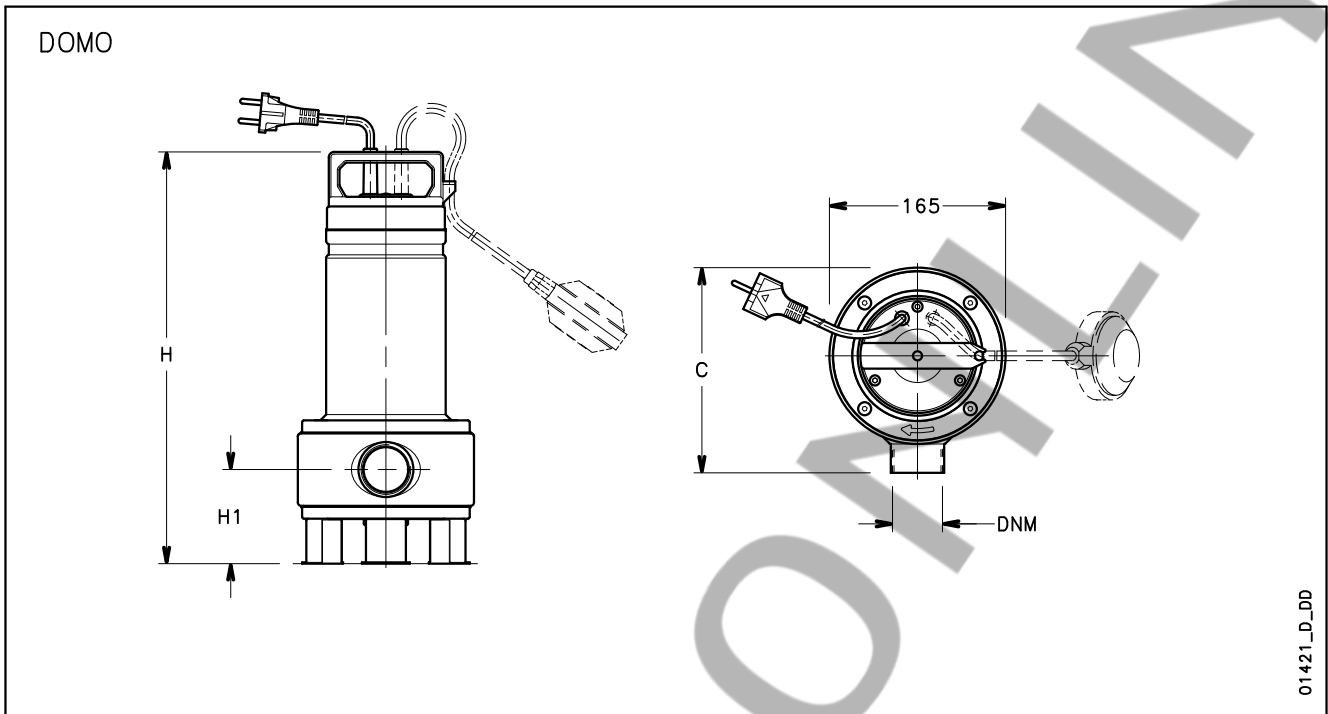

PUMP TYPE SINGLE-PHASE		DIMENSIONS (mm)			DNM	WEIGHT kg
		H	H1	C		
DOMO 7	DOMO 7 GT	391	88	193	Rp1½	10,2
DOMO 7VX	DOMO 7VX GT					
DOMO10	DOMO10 GT	468	111,5	198	Rp2	13,6
DOMO10VX	DOMO10VX GT					
DOMO15	DOMO15 GT	468	111,5	198	Rp2	15,3
DOMO15VX	DOMO15VX GT					
-	-	-	-	-	-	-

PUMP TYPE THREE-PHASE		DIMENSIONS (mm)			DNM	WEIGHT kg
		H	H1	C		
DOMO 7T	DOMO 7VXT	391	88	193	Rp1½	8,9
DOMO10T	DOMO10VXT					
DOMO15T	DOMO15VXT	468	111,5	198	Rp2	13,6
DOMO20T	DOMO20VXT					

domo-2p50-en\_c\_td

