

50 Hz



e-SH Series

HORIZONTAL CENTRIFUGAL ELECTRIC PUMPS ACCORDING TO EN 733
MADE IN AISI 316 STAINLESS STEEL AND EQUIPPED WITH **IE3** MOTORS

ErP 2009/125/EC

ESH 65, 80 SERIES HYDRAULIC PERFORMANCE TABLE AT 50 Hz, 2 POLES

PUMP TYPE	P _N kW	Ø Impeller (mm)			Q = DELIVERY											
		○ ● (1)	η _p % (2)	l/s	8,1	10,6	13,3	15,8	18,3	21,1	23,6	26,4	28,9	31,4	34,2	36,7
				m ³ /h	0	29	38	48	57	66	76	85	95	104	113	123
H = TOTAL HEAD METRES COLUMN OF WATER																
65-160/40	4	127	○	71,0	19,1	18,7	17,8	16,5	14,9	13,0	10,9	8,6	6,4			
65-160/55	5,5	140	○	75,1	24,6		23,4	22,2	20,8	19,1	17,2	15,1	12,7	10,1	7,4	
65-160/75	7,5	154	○	74,7	30,7			28,4	26,7	24,9	22,9	20,8	18,5	16,0	13,2	
65-160/92	9,2	164	○	77,6	35,7			33,8	32,5	30,9	28,9	26,5	23,8	20,8	17,5	
65-160/110A	11	164	○	77,6	35,7			33,8	32,5	30,9	28,9	26,5	23,8	20,8	17,5	
65-160/110	11	176	●	76,0	41,6			38,5	36,8	34,6	32,1	29,4	26,6			
65-200/150	15	192	○	70,0	53,6			50,0	48,1	45,9	43,2	40,3	37,0	33,4	29,7	
65-200/185	18,5	203	○	71,5	60,7			55,8	53,7	51,2	48,4	45,2	41,8	38,2		
65-200/220	22	210	●	71,5	63,9			60,4	58,6	56,4	53,9	51,0	47,8	44,3	40,7	
65-250/300	30	240	○	74,5	83,7				80,7	78,8	76,5	73,8	70,7	67,0	62,9	
65-250/370	37	255	●	73,5	96,5				93,8	91,8	89,4	86,7	83,6	80,1	76,3	72,2

PUMP TYPE	P _N kW	Ø Impeller (mm)			Q = DELIVERY												
		○ ● (1)	η _p % (2)	l/s	20,0	24,2	28,6	32,8	36,9	41,1	45,6	49,7	53,9	58,1	62,5	66,7	
				m ³ /h	0	72	87	103	118	133	148	164	179	194	209	225	240
H = TOTAL HEAD METRES COLUMN OF WATER																	
80-160/110	11	169x15°	○	75,0	34,0	31,7	30,3	28,4	26,2	23,6	20,7	17,7	14,6	11,6			
80-160/150	15	177	○	76,5	40,8	38,6	37,2	35,4	33,3	30,7	27,9	24,9	21,7	18,4	15,3		
80-160/185	18,5	186	●	78,0	47,8	45,4	44,1	42,4	40,3	38,0	35,3	32,4	29,3	26,0	22,6		
80-200/220	22	198	○	80,5	53,5	51,2	49,9	48,2	46,2	43,9	41,3	38,4	35,3	32,0	28,7		
80-200/300	30	215	○	81,0	64,0	62,4	61,2	59,7	57,7	55,4	52,7	49,7	46,5	43,0	39,5	36,1	
80-200/370	37	226	●	81,5	71,7	70,5	69,5	68,2	66,5	64,3	61,8	59,0	55,8	52,4	48,8	45,1	41,5
80-250/450	45	237	○	79,5	83,9			78,8	76,5	73,8	70,6	66,9	62,9	58,5	53,8		
80-250/550	55	252	○	80,0	95,9			91,8	89,7	87,2	84,2	80,8	76,9	72,8	68,5		
80-250/750	75	270	●	78,0	112,2			108,4	106,5	104,1	101,2	98,0	94,3	90,2	85,9	81,4	

Hydraulic performances in compliance with ISO 9906:2012 - Grade 3B (ex ISO 9906:1999 - Annex A)

ESH-65-80_2p50-en_c_th

(1) ● = Full impeller diameter - ○ = Trimmed impeller diameter (2) Hydraulic efficiency of pump.

ESH SERIES
OPERATING CHARACTERISTICS AT 50 Hz, 2 POLES

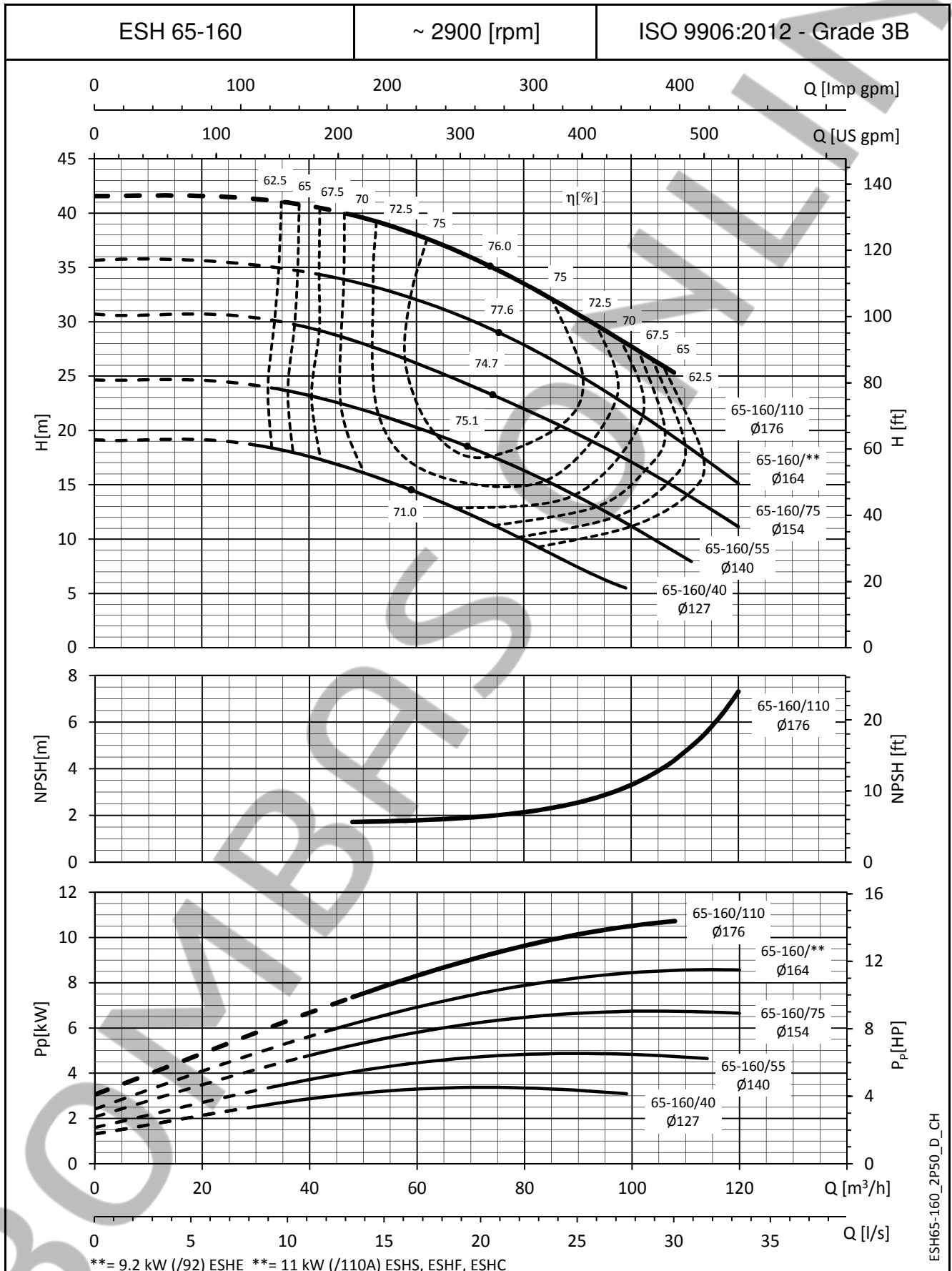

The NPSH values are laboratory values; for practical use we suggest increasing these values by 0,5 m.
These performances are valid for liquids with density $\rho = 1,0 \text{ Kg/dm}^3$ and kinematic viscosity $\nu = 1 \text{ mm}^2/\text{sec}$.

ESH SERIES
OPERATING CHARACTERISTICS AT 50 Hz, 2 POLES

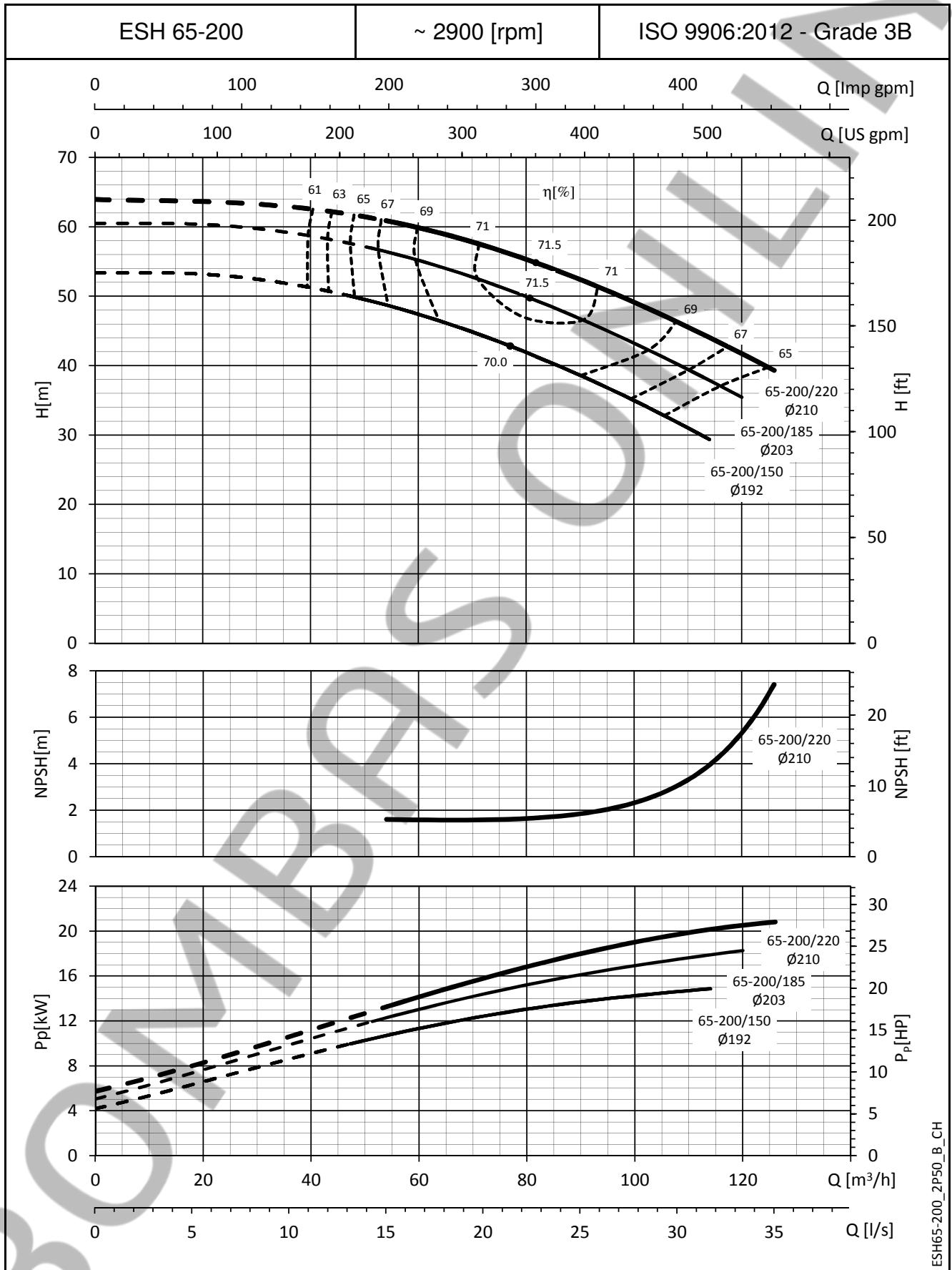

ESH65-200_2P50_B_CH

The NPSH values are laboratory values; for practical use we suggest increasing these values by 0,5 m.
These performances are valid for liquids with density $\rho = 1,0 \text{ Kg/dm}^3$ and kinematic viscosity $\nu = 1 \text{ mm}^2/\text{sec}$.

ESH SERIES
OPERATING CHARACTERISTICS AT 50 Hz, 2 POLES

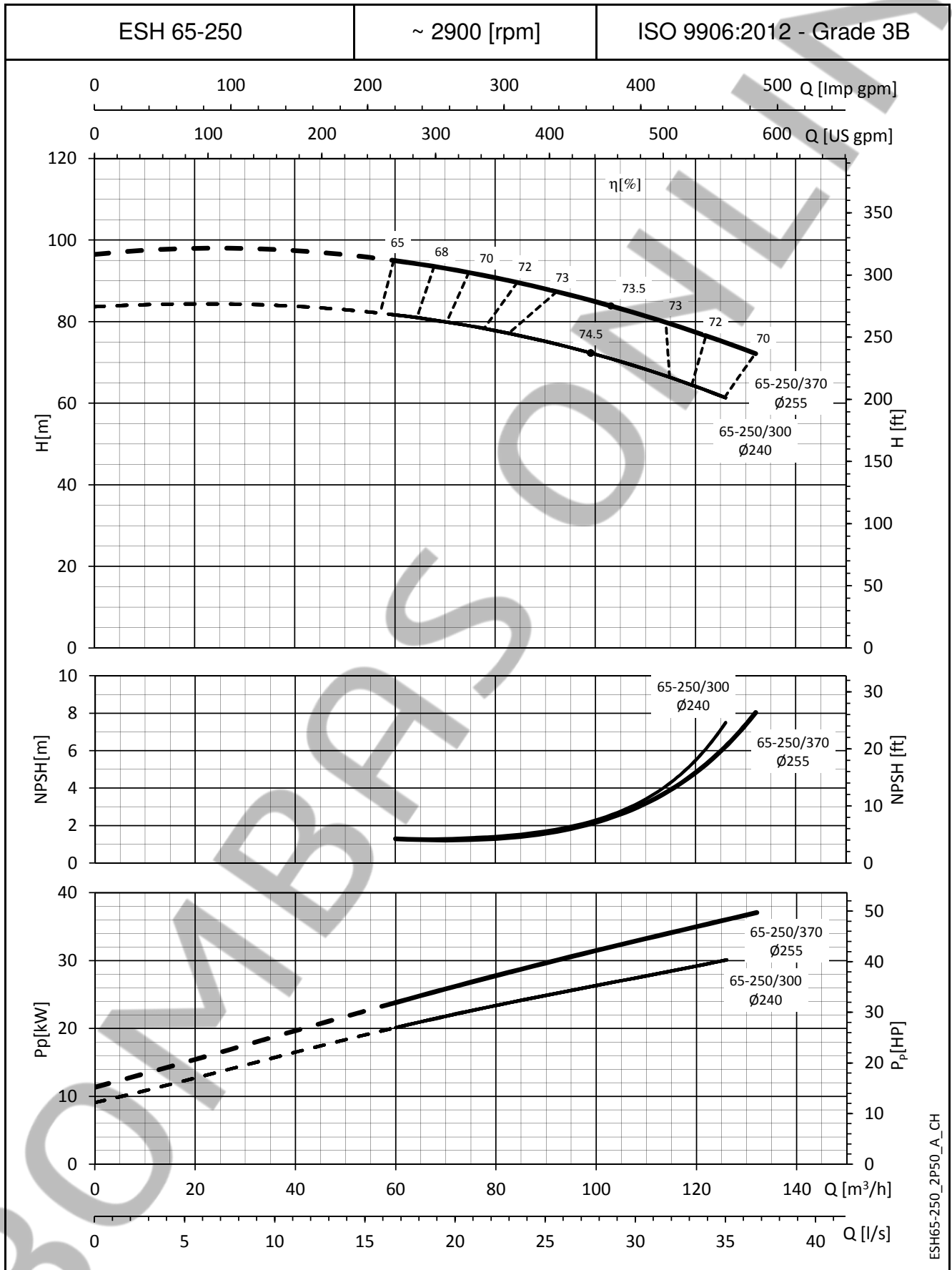

ESH65-250_2P50_A_CH

The NPSH values are laboratory values; for practical use we suggest increasing these values by 0,5 m.
These performances are valid for liquids with density $\rho = 1,0 \text{ Kg/dm}^3$ and kinematic viscosity $\nu = 1 \text{ mm}^2/\text{sec}$.

ESHS SERIES
DIMENSIONS AND WEIGHTS AT 50 Hz, 2 POLES

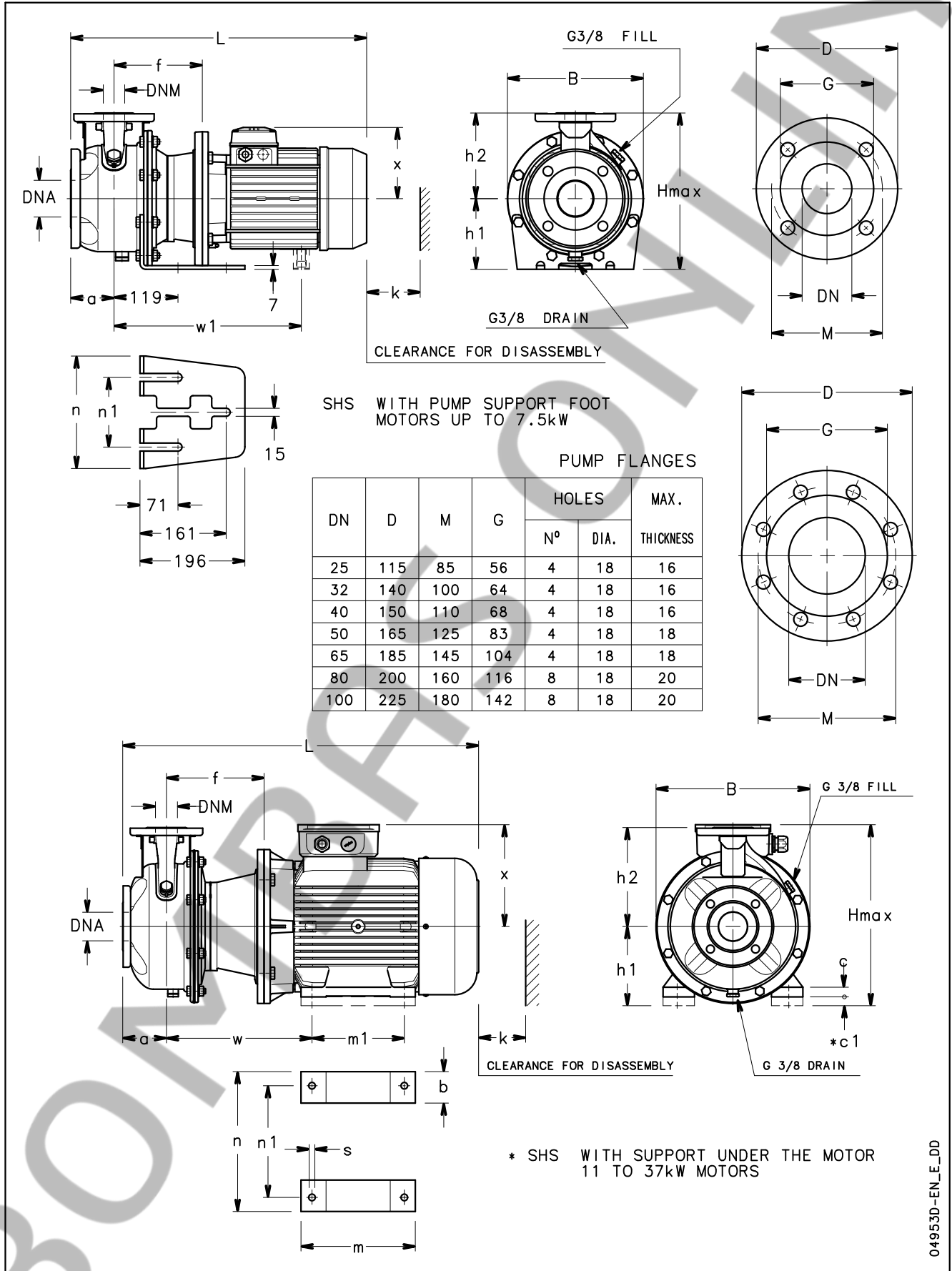

04953D-EN_E_DD

ESHS SERIES DIMENSIONS AND WEIGHTS AT 50 Hz, 2 POLES

PUMP TYPE ESHS..2	DIMENSIONS (mm)																	B	H max	L	k	WEIGHT kg
	PUMP							SUPPORT														
	DNM	DNA	a	f	h2	w	w1	x	b	c	*c1	h1	m	m1	n	n1	s					
25-125/07/S	25	50	80	155	140	-	-	129	-	-	-	160	-	-	190	130	-	218	300	498	98	24
25-125/11/S	25	50	80	155	140	-	-	129	-	-	-	160	-	-	190	130	-	218	300	498	98	25
25-160/15/S	25	50	80	155	160	-	-	129	-	-	-	160	-	-	210	130	-	253	320	498	98	27
25-160/22/P	25	50	80	155	160	-	-	134	-	-	-	160	-	-	210	130	-	253	320	533	98	33
25-200/30/P	25	50	80	165	180	-	-	134	-	-	-	160	-	-	230	130	-	284	340	543	98	44
25-200/40/P	25	50	80	165	180	-	-	154	-	-	-	160	-	-	230	130	-	284	340	564	98	51
25-250/55/P	25	50	100	192	225	-	399	168	-	-	-	180	-	-	265	130	-	345	405	667	98	77
25-250/75/P	25	50	100	192	225	-	397	191	-	-	-	180	-	-	265	130	-	345	405	659	98	91
25-250/110/P	25	50	100	222	225	330	-	240	49	5	20	180	304	210	304	254	15	350	420	816	98	130
32-125/07/S	32	50	80	155	140	-	-	129	-	-	-	112	-	-	190	130	-	218	252	498	98	24
32-125/11/S	32	50	80	155	140	-	-	129	-	-	-	112	-	-	190	130	-	218	252	498	98	25
32-160/15/S	32	50	80	155	160	-	-	129	-	-	-	132	-	-	210	130	-	253	292	498	98	27
32-160/22/P	32	50	80	155	160	-	-	134	-	-	-	132	-	-	210	130	-	253	292	533	98	33
32-200/30/P	32	50	80	165	180	-	-	134	-	-	-	160	-	-	230	130	-	284	340	543	98	44
32-200/40/P	32	50	80	165	180	-	-	154	-	-	-	160	-	-	230	130	-	284	340	564	98	51
32-250/55/P	32	50	100	192	225	-	399	168	-	-	-	180	-	-	265	130	-	345	405	667	98	77
32-250/75/P	32	50	100	192	225	-	397	191	-	-	-	180	-	-	265	130	-	345	405	659	98	91
32-250/110/P	32	50	100	222	225	330	-	240	49	5	20	180	304	210	304	254	15	350	420	816	98	130
40-125/11/S	40	65	80	155	140	-	-	129	-	-	-	112	-	-	190	130	-	218	252	498	100	26
40-125/15/S	40	65	80	155	140	-	-	129	-	-	-	112	-	-	190	130	-	218	252	498	100	26
40-125/22/P	40	65	80	155	140	-	-	134	-	-	-	112	-	-	190	130	-	218	252	533	100	32
40-160/30/P	40	65	80	165	160	-	-	134	-	-	-	132	-	-	210	130	-	253	292	543	100	42
40-160/40/P	40	65	80	165	160	-	-	154	-	-	-	132	-	-	210	130	-	253	292	564	100	48
40-200/55/P	40	65	100	192	180	-	399	168	-	-	-	160	-	-	230	130	-	300	340	667	100	63
40-200/75/P	40	65	100	192	180	-	397	191	-	-	-	160	-	-	230	130	-	300	351	659	100	80
40-250/110A/P	40	65	100	222	225	330	-	240	49	5	20	180	304	210	304	254	15	350	420	816	107	129
40-250/110/P	40	65	100	222	225	330	-	240	49	5	20	180	304	210	304	254	15	350	420	816	107	129
40-250/150/P	40	65	100	222	225	330	-	240	49	5	20	180	304	210	304	254	15	350	420	816	107	142
50-125/22/P	50	65	100	155	160	-	-	134	-	-	-	132	-	-	210	130	-	253	292	553	104	36
50-125/30/P	50	65	100	165	160	-	-	134	-	-	-	132	-	-	210	130	-	253	292	563	104	37
50-125/40/P	50	65	100	165	160	-	-	154	-	-	-	132	-	-	210	130	-	253	292	584	104	48
50-160/55/P	50	65	100	192	180	-	399	168	-	-	-	160	-	-	210	130	-	300	340	667	104	62
50-160/75/P	50	65	100	192	180	-	397	191	-	-	-	160	-	-	210	130	-	300	351	659	104	81
50-200/110A/P	50	65	100	222	200	330	-	240	49	5	20	180	304	210	304	254	15	350	420	816	104	126
50-200/110/P	50	65	100	222	200	330	-	240	49	5	20	180	304	210	304	254	15	350	420	816	104	130
50-250/150/P	50	65	100	222	225	330	-	240	49	5	20	180	304	210	304	254	15	350	420	816	107	148
50-250/185/P	50	65	100	222	225	330	-	240	49	5	20	180	304	254	304	254	15	350	420	816	107	156
50-250/220/P	50	65	100	222	225	330	-	240	49	5	20	180	304	254	304	254	15	350	420	816	107	162
65-160/40/P	65	80	100	165	200	-	-	154	-	-	-	160	-	-	245	130	-	310	360	584	130	60
65-160/55/P	65	80	100	192	200	-	399	168	-	-	-	160	-	-	245	130	-	310	360	667	130	78
65-160/75/P	65	80	100	192	200	-	397	191	-	-	-	160	-	-	245	130	-	310	360	659	130	93
65-160/110A/P	65	80	100	222	200	330	-	240	49	5	20	180	304	210	304	254	15	350	420	816	130	116
65-160/110/P	65	80	100	222	200	330	-	240	49	5	20	180	304	210	304	254	15	350	420	816	130	120
65-200/150/P	65	80	100	222	225	330	-	240	49	5	20	180	304	210	304	254	15	350	420	816	130	147
65-200/185/P	65	80	100	222	225	330	-	240	49	5	20	180	304	254	304	254	15	350	420	816	130	153
65-200/220/P	65	80	100	222	225	330	-	240	49	5	20	180	304	254	304	254	15	350	420	816	130	167
65-250/300/W	65	80	100	228	250	361	-	317	82	30	-	200	370	305	385	318	18	402	517	985	140	290
65-250/370/W	65	80	100	228	250	361	-	317	82	30	-	200	370	305	385	318	18	402	517	985	140	322
80-160/110/P	80	100	125	222	225	330	-	240	49	5	20	180	304	210	304	254	15	350	420	841	160	116
80-160/150/P	80	100	125	222	225	330	-	240	49	5	20	180	304	210	304	254	15	350	420	841	160	152
80-160/185/P	80	100	125	222	225	330	-	240	49	5	20	180	304	254	304	254	15	350	420	841	160	160
80-200/220/P	80	100	125	222	250	330	-	240	49	5	20	180	304	254	304	254	15	350	430	841	160	162
80-200/300/W	80	100	125	228	250	361	-	317	82	30	-	200	370	305	385	318	18	402	517	985	160	312
80-200/370/W	80	100	125	228	250	361	-	317	82	30	-	200	370	305	385	318	18	402	517	985	160	317

* Motor shim on request

ESHS_2p50-en_a_tit