

50 Hz



e-SH Series

HORIZONTAL CENTRIFUGAL ELECTRIC PUMPS ACCORDING TO EN 733
MADE IN AISI 316 STAINLESS STEEL AND EQUIPPED WITH **IE3** MOTORS

ErP 2009/125/EC

ESH 25, 32, 40, 50 SERIES HYDRAULIC PERFORMANCE TABLE AT 50 Hz, 2 POLES

PUMP TYPE	P _N kW	Ø Impeller (mm)		Q = DELIVERY													
		○ ● (1)	η _p % (2)	l/s m ³ /h	0	1,9 7	2,5 9	3,1 11	3,6 13	4,2 15	4,7 17	5,3 19	6,1 22	6,7 24	7,2 26	7,8 28	8,3 30
H = TOTAL HEAD METRES COLUMN OF WATER																	
25-125/07*	0,75	114	○	59,7	16,1		14,1	13,1	12,0	10,7	9,2	7,6					
25-125/11*	1,1	128	●	63,8	20,7		19,0	18,1	17,1	16,0	14,6	13,2	10,7				
25-160/15*	1,5	141	○	55,9	24,4		23,0	22,0	20,7	19,2	17,4	15,4	12,1	9,7			
25-160/22*	2,2	154	●	58,1	30,6		29,2	28,4	27,3	25,9	24,2	22,2	19,0	16,7			
25-200/30	3	178	○	55,0	38,8		35,7	34,5	33,2	31,6	29,7	27,6	24,0	21,4			
25-200/40	4	195	●	57,6	48,4		45,6	44,7	43,6	42,2	40,7	38,9	35,8	33,5	31,0		
25-250/55	5,5	203	○	50,3	53,0	51,5	50,7	49,8	48,7	47,4	45,8	44,1	41,0				
25-250/75	7,5	223,5	○	48,7	66,5		64,4	63,4	62,1	60,7	59,0	57,0	53,8	51,3	48,6		
25-250/110	11	244,5	●	49,0	82,4		79,7	78,6	77,4	75,9	74,3	72,5	69,4	67,2	64,8	62,2	59,4
32-125/07*	0,75	114	○	62,4	16,0		14,4	13,5	12,5	11,4	10,2	8,9	6,6				
32-125/11*	1,1	128	●	64,4	20,7		19,0	18,2	17,2	16,1	14,8	13,5	11,2	9,7			
32-160/15*	1,5	141	○	57,2	24,6		23,3	22,4	21,2	19,7	18,1	16,3	13,3	11,1			
32-160/22*	2,2	154	●	60,7	30,8		29,7	28,9	27,9	26,6	25,1	23,5	20,8	18,8	16,7		
32-200/30	3	178	○	56,8	39,4		36,7	35,7	34,5	33,2	31,7	30,0	27,2	25,1			
32-200/40	4	195	●	56,4	49,0		45,8	44,7	43,3	41,8	40,1	38,2	35,1	32,7	30,1		
32-250/55	5,5	203	○	50,7	53,0	51,7	51,0	50,1	49,0	47,8	46,3	44,6	41,6				
32-250/75	7,5	223,5	○	50,4	66,5		64,8	63,9	62,8	61,5	60,0	58,2	55,1	52,8	50,1		
32-250/110	11	244,5	●	50,1	82,1		80,3	79,3	78,0	76,5	74,8	73,0	70,1	68,1	65,9	63,5	61,0

PUMP TYPE	P _N kW	Ø Impeller (mm)		Q = DELIVERY													
		○ ● (1)	η _p % (2)	l/s m ³ /h	0	3,9 14	4,7 17	5,8 21	6,7 24	7,5 27	8,6 31	9,4 34	10,6 38	11,4 41	12,2 44	13,3 48	14,2 51
H = TOTAL HEAD METRES COLUMN OF WATER																	
40-125/11*	1,1	112	○	67,9	15,7	14,1	13,3	12,0	10,9	9,8	8,2	7,0	5,2				
40-125/15*	1,5	125	○	71,7	19,9		17,4	16,2	15,2	14,0	12,4	11,2	9,4	8,0			
40-125/22*	2,2	133	●	70,5	23,4			20,3	19,4	18,3	16,8	15,6	13,8	12,3	10,8		
40-160/30	3	152	○	64,0	30,9			27,7	26,4	24,9	22,7	20,9	18,6	16,8	15,0		
40-160/40	4	171	●	69,4	37,9			34,4	33,2	31,8	29,7	27,9	25,4	23,4	21,4	18,6	
40-200/55	5,5	190	○	65,0	49,1			45,2	43,8	42,2	39,7	37,6	34,5	31,9	29,1	25,0	
40-200/75	7,5	209	●	66,5	58,2			53,9	52,4	50,8	48,4	46,3	43,3	40,9	38,2	34,4	
40-250/92	9,2	218	○	59,0	64,9			60,9	59,6	58,1	55,6	53,3	49,5	45,9			
40-250/110A	11	218	○	59,0	64,9			60,9	59,6	58,1	55,6	53,3	49,5	45,9			
40-250/110	11	233	○	58,5	74,6			70,3	69,0	67,6	65,2	63,1	59,6	56,4	52,7		
40-250/150	15	251	●	58,0	87,7			82,9	81,6	80,1	77,8	75,9	72,9	70,2	67,2	62,4	58,2

PUMP TYPE	P _N kW	Ø Impeller (mm)		Q = DELIVERY													
		○ ● (1)	η _p % (2)	l/s m ³ /h	0	7,8 28	9,2 33	10,8 39	12,2 44	13,9 50	15,6 56	17,2 62	18,6 67	20,3 73	21,9 79	23,3 84	25,0 90
H = TOTAL HEAD METRES COLUMN OF WATER																	
50-125/22*	2,2	114	○	73,1	17,5	15,5	14,7	13,6	12,5	11,2	9,7	8,1	6,7				
50-125/30	3	123	○	74,1	20,6		18,5	17,4	16,3	14,9	13,4	11,7	10,3	8,6			
50-125/40	4	131	●	75,1	24,8			22,1	21,0	19,7	18,2	16,6	15,2	13,5	11,7	10,2	
50-160/55	5,5	158	○	71,7	33,8			30,5	29,3	27,7	25,9	24,0	22,3	20,2	18,0	16,1	
50-160/75	7,5	174	●	74,0	40,7			36,8	35,6	34,1	32,4	30,6	28,8	26,5	24,0	21,7	18,6
50-200/92	9,2	197	○	70,0	52,9			46,4	44,6	42,0	39,1	35,9	32,9	29,0	24,6	20,8	
50-200/110A	11	197	○	70,0	52,9			46,4	44,6	42,0	39,1	35,9	32,9	29,0	24,6	20,8	
50-200/110	11	209	●	72,0	59,7			53,5	51,7	49,3	46,4	43,2	40,2	36,3	32,0	28,1	
50-250/150	15	224	○	69,5	70,2			65,9	64,6	62,7	60,3	57,3	54,3	50,0			
50-250/185	18,5	237	○	68,4	79,9			74,1	72,7	70,6	68,2	65,4	62,7	58,9	54,4		
50-250/220	22	250	●	67,3	88,9			83,7	82,2	80,2	77,8	75,0	72,4	68,8	64,7	60,7	

Hydraulic performances in compliance with ISO 9906:2012 - Grade 3B (ex ISO 9906:1999 - Annex A)

ESH-25-32-40-50_2p50-en_c_th

(1) ● = Full impeller diameter - ○ = Trimmed impeller diameter (2) Hydraulic efficiency of pump.

*Available also in single-phase version.

ESH SERIES
OPERATING CHARACTERISTICS AT 50 Hz, 2 POLES

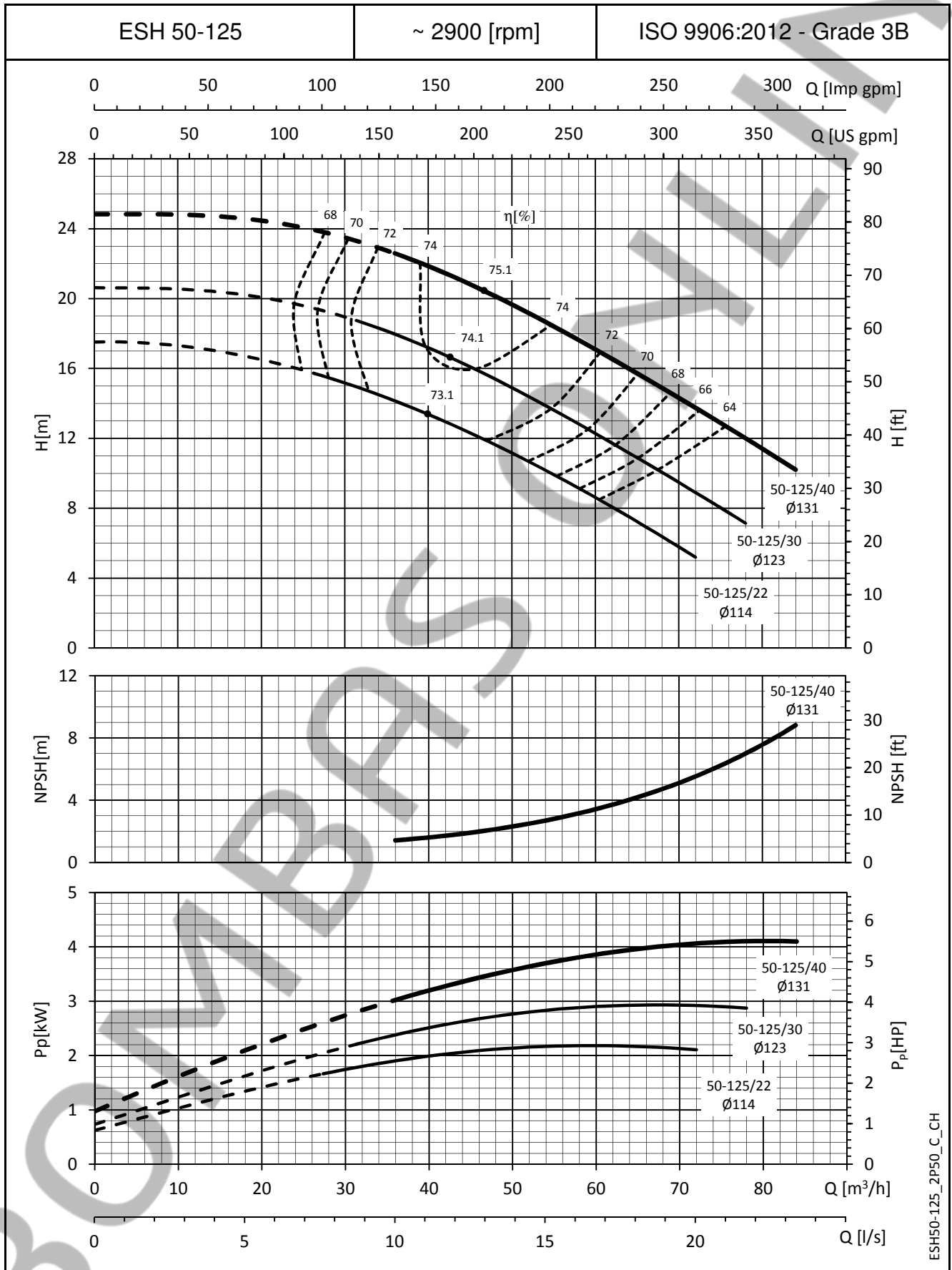

ESH50-125_2P50_C_CH

The NPSH values are laboratory values; for practical use we suggest increasing these values by 0,5 m.
These performances are valid for liquids with density $\rho = 1,0 \text{ Kg/dm}^3$ and kinematic viscosity $\nu = 1 \text{ mm}^2/\text{sec}$.

ESH SERIES
OPERATING CHARACTERISTICS AT 50 Hz, 2 POLES

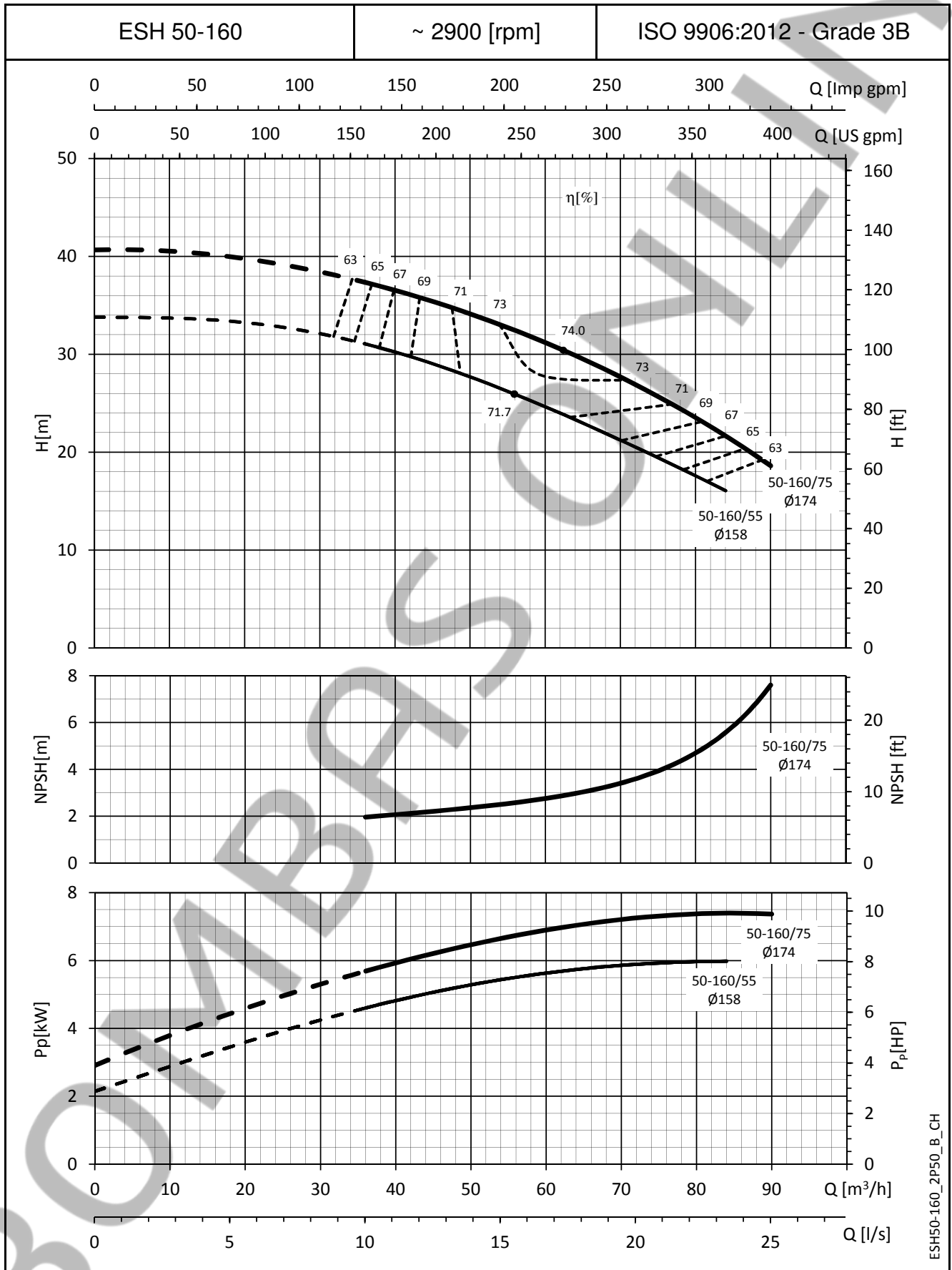

ESH50-160_2P50_B_CH

The NPSH values are laboratory values; for practical use we suggest increasing these values by 0,5 m.
These performances are valid for liquids with density $\rho = 1,0 \text{ Kg/dm}^3$ and kinematic viscosity $\nu = 1 \text{ mm}^2/\text{sec}$.

ESH SERIES
OPERATING CHARACTERISTICS AT 50 Hz, 2 POLES

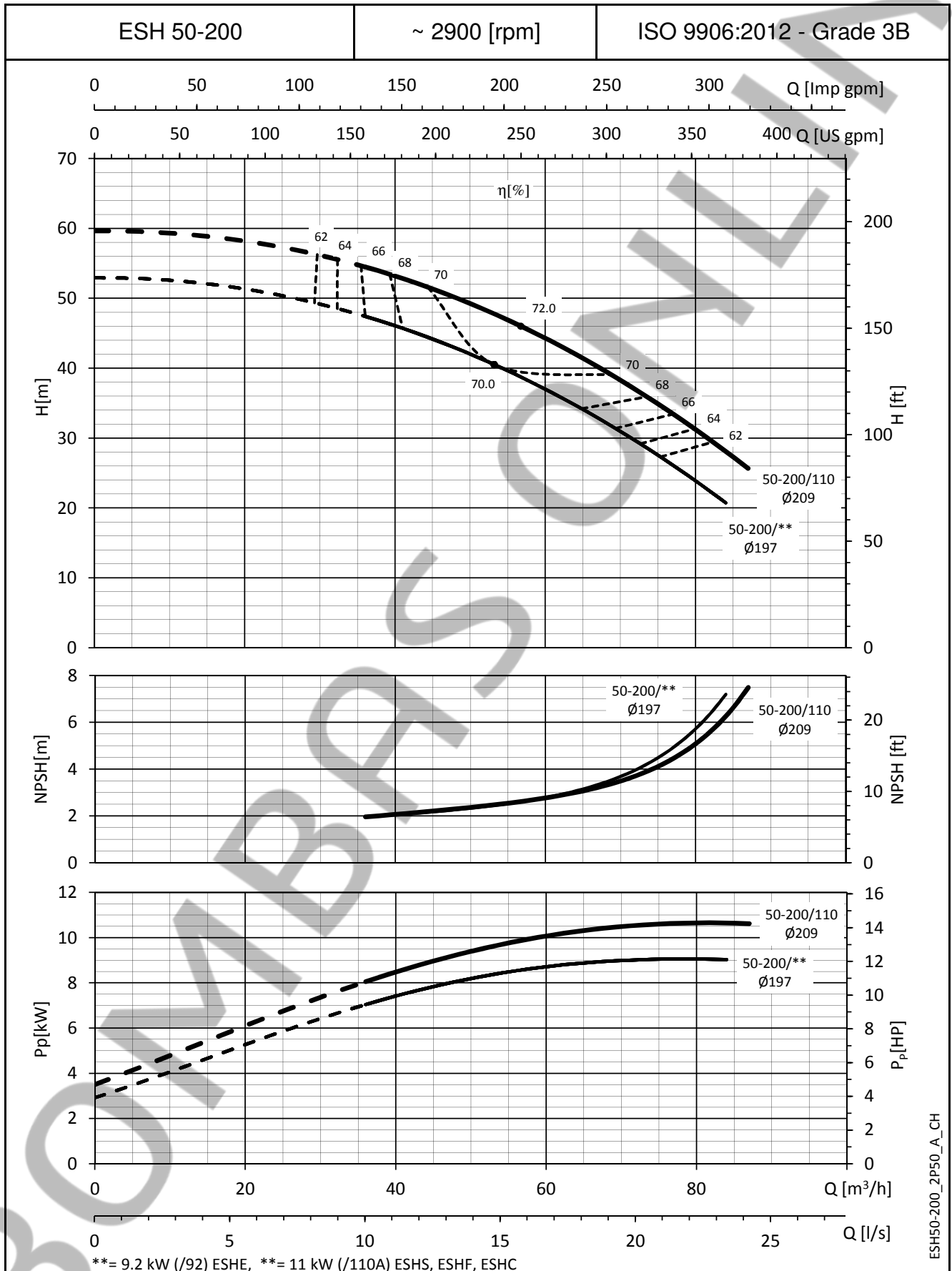

The NPSH values are laboratory values; for practical use we suggest increasing these values by 0,5 m.
 These performances are valid for liquids with density $\rho = 1,0 \text{ Kg/dm}^3$ and kinematic viscosity $\nu = 1 \text{ mm}^2/\text{sec}$.

ESH SERIES
OPERATING CHARACTERISTICS AT 50 Hz, 2 POLES

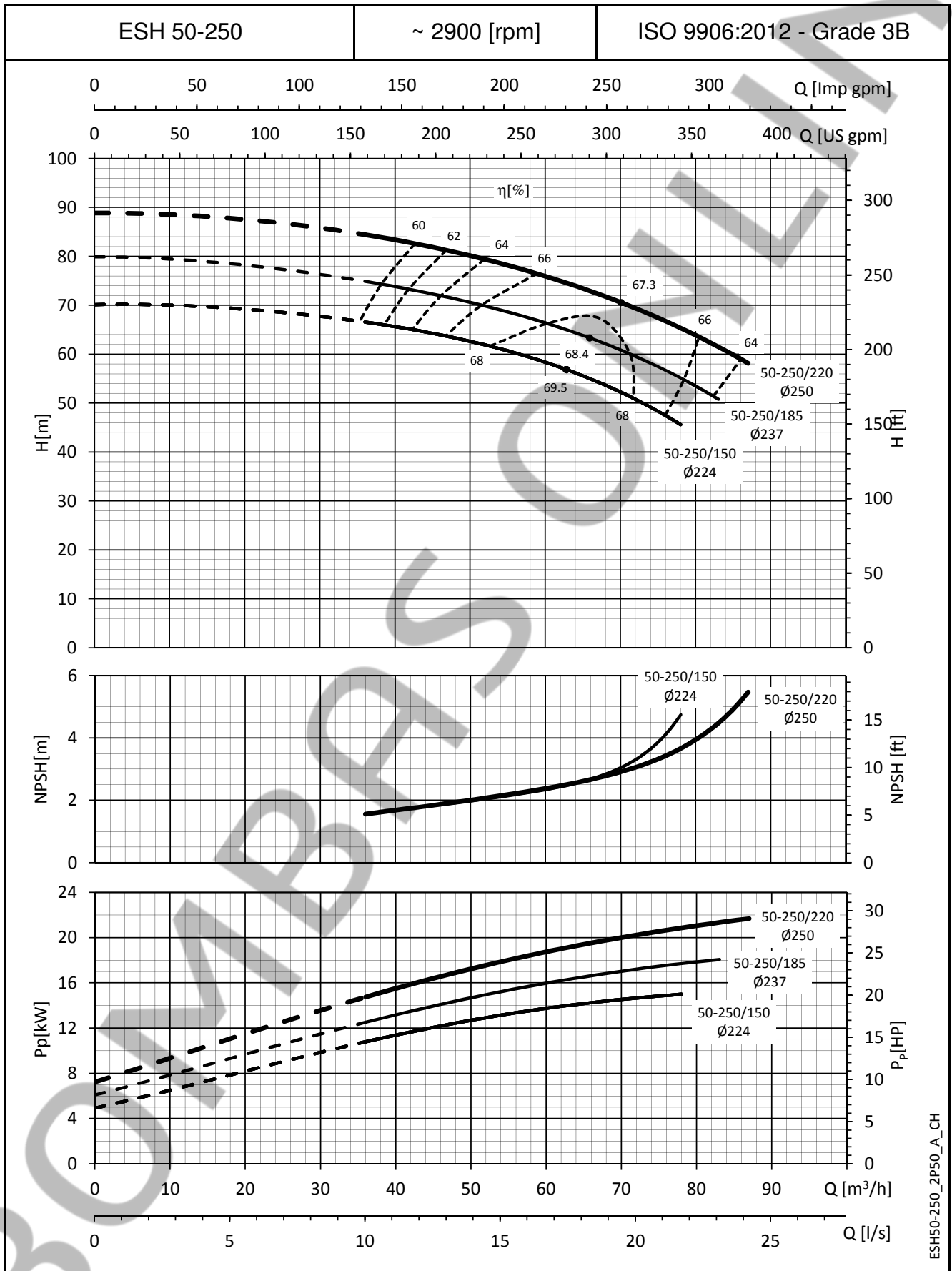

ESH50-250_2P50_A_CH

The NPSH values are laboratory values; for practical use we suggest increasing these values by 0,5 m.
These performances are valid for liquids with density $\rho = 1,0 \text{ Kg/dm}^3$ and kinematic viscosity $\nu = 1 \text{ mm}^2/\text{sec}$.

ESHF SERIES
DIMENSIONS AND WEIGHTS AT 50 Hz, 2 POLES

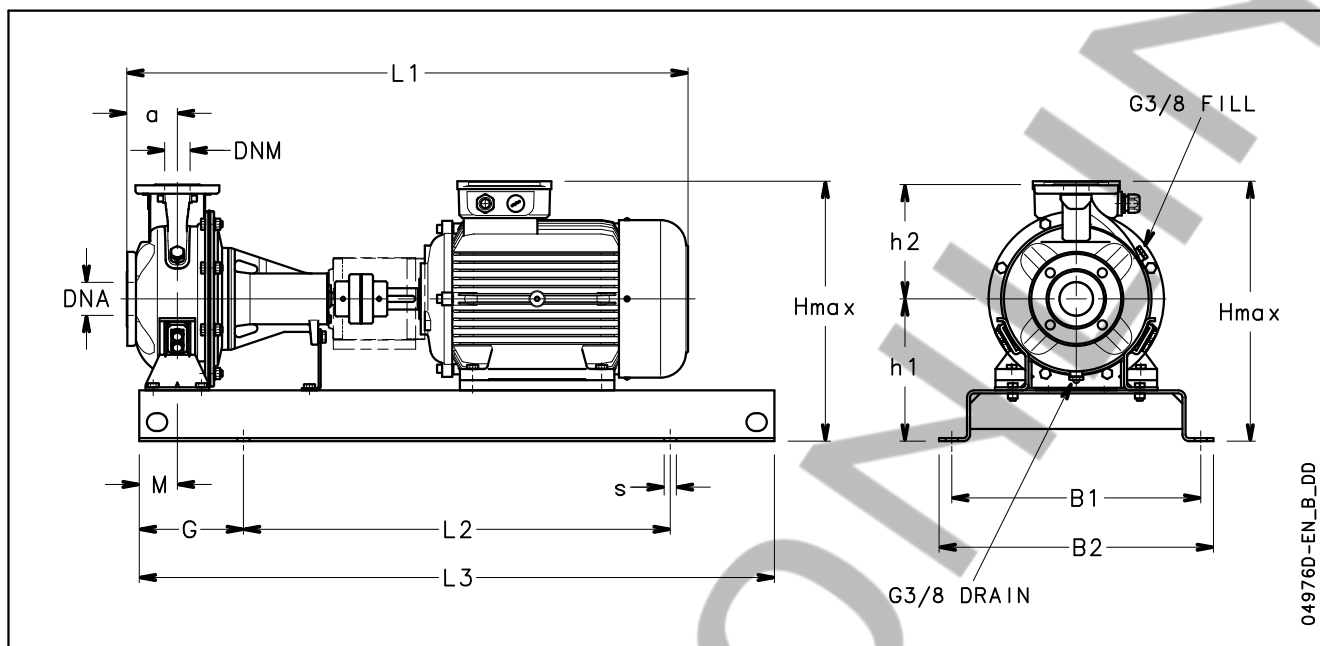

ESHF SERIES DIMENSIONS AND WEIGHTS AT 50 Hz, 2 POLES

PUMP TYPE ESHF..2	DIMENSIONS (mm)													s FOR SCREWS	WEIGHT kg	COUPLING TYPE
	DNM	DNA	a	B1	B2	L1	L2	L3	G	M	h1	h2	Hmax			
25-125/07/S	25	50	80	320	360	746	540	800	130	60	212	140	352	M16	67	A2
25-125/11/S	25	50	80	320	360	746	540	800	130	60	212	140	352	M16	69	A2
25-160/15/P	25	50	80	350	390	791	600	900	150	60	232	160	392	M16	73	A3
25-160/22/P	25	50	80	350	390	791	600	900	150	60	232	160	392	M16	75	A3
25-200/30/P	25	50	80	350	390	822	600	900	150	60	260	180	440	M16	95	B1
25-200/40/P	25	50	80	350	390	825	600	900	150	60	260	180	440	M16	97	B1
25-250/55/P	25	50	100	440	490	910	740	1120	190	75	280	225	505	M20	130	C1
25-250/75/P	25	50	100	440	490	910	740	1120	190	75	280	225	505	M20	134	C1
25-250/110/P	25	50	100	490	540	1067	840	1250	205	75	280	225	520	M20	181	C2
32-125/07/S	32	50	80	320	360	746	540	800	130	60	212	140	352	M16	67	A2
32-125/11/S	32	50	80	320	360	746	540	800	130	60	212	140	352	M16	69	A2
32-160/15/P	32	50	80	350	390	791	600	900	150	60	232	160	392	M16	73	A3
32-160/22/P	32	50	80	350	390	791	600	900	150	60	232	160	392	M16	75	A3
32-200/30/P	32	50	80	350	390	822	600	900	150	60	260	180	440	M16	95	B1
32-200/40/P	32	50	80	350	390	825	600	900	150	60	260	180	440	M16	97	B1
32-250/55/P	32	50	100	440	490	910	740	1120	190	75	280	225	505	M20	130	C1
32-250/75/P	32	50	100	440	490	910	740	1120	190	75	280	225	505	M20	134	C1
32-250/110/P	32	50	100	490	540	1067	840	1250	205	75	280	225	520	M20	181	C2
40-125/11/S	40	65	80	350	390	746	600	900	150	60	212	140	352	M16	70	A2
40-125/15/P	40	65	80	350	390	791	600	900	150	60	212	140	352	M16	74	A3
40-125/22/P	40	65	80	350	390	791	600	900	150	60	212	140	352	M16	77	A3
40-160/30/P	40	65	80	350	390	822	600	900	150	60	232	160	392	M16	92	B1
40-160/40/P	40	65	80	350	390	825	600	900	150	60	232	160	400	M16	96	B1
40-200/55/P	40	65	100	400	450	910	660	1000	170	60	260	180	451	M20	123	C1
40-200/75/P	40	65	100	400	450	910	660	1000	170	60	260	180	451	M20	128	C1
40-250/110A/P	40	65	100	490	540	1067	840	1250	205	75	280	225	520	M20	167	C2
40-250/110/P	40	65	100	490	540	1067	840	1250	205	75	280	225	520	M20	170	C2
40-250/150/P	40	65	100	490	540	1067	840	1250	205	75	280	225	520	M20	175	C2
50-125/22/P	50	65	100	350	390	811	600	900	150	60	232	160	392	M16	84	A3
50-125/30/P	50	65	100	350	390	842	600	900	150	60	232	160	392	M16	92	B1
50-125/40/P	50	65	100	350	390	845	600	900	150	60	232	160	400	M16	95	B1
50-160/55/P	50	65	100	400	450	910	660	1000	170	60	260	180	451	M20	120	C1
50-160/75/P	50	65	100	400	450	910	660	1000	170	60	260	180	451	M20	122	C1
50-200/110A/P	50	65	100	440	490	1067	740	1120	190	60	260	200	500	M20	145	C2
50-200/110/P	50	65	100	440	490	1067	740	1120	190	60	260	200	500	M20	150	C2
50-250/150/P	50	65	100	490	540	1067	840	1250	205	75	280	225	520	M20	165	C2
50-250/185/P	50	65	100	490	540	1067	840	1250	205	75	280	225	520	M20	170	C2
50-250/220/W	50	65	100	490	540	1127	840	1250	205	75	280	225	559	M20	272	D1
65-160/40/P	65	80	100	400	450	845	660	1000	170	75	260	200	460	M20	133	B1
65-160/55/P	65	80	100	440	490	910	740	1120	190	75	260	200	460	M20	155	C1
65-160/75/P	65	80	100	440	490	910	740	1120	190	75	260	200	460	M20	159	C1
65-160/110A/P	65	80	100	490	540	1067	840	1250	205	75	260	200	500	M20	162	C2
65-160/110/P	65	80	100	490	540	1067	840	1250	205	75	260	200	500	M20	162	C2
65-200/150/P	65	80	100	490	540	1067	840	1250	205	75	280	225	520	M20	185	C2
65-200/185/P	65	80	100	490	540	1067	840	1250	205	75	280	225	520	M20	190	C2
65-200/220/W	65	80	100	490	540	1127	840	1250	205	75	280	225	559	M20	265	D1
65-250/300/W	65	80	100	550	610	1340	940	1400	230	90	310	250	627	M24	359	E1
65-250/370/W	65	80	100	550	610	1340	940	1400	230	90	310	250	627	M24	375	E1
80-160/110/P	80	100	125	490	540	1092	840	1250	205	75	280	225	520	M20	198	C2
80-160/150/P	80	100	125	490	540	1092	840	1250	205	75	280	225	520	M20	209	C2
80-160/185/P	80	100	125	490	540	1092	840	1250	205	75	280	225	520	M20	220	C2
80-200/220/W	80	100	125	490	540	1262	840	1250	205	75	280	250	559	M20	278	D2
80-200/300/W	80	100	125	550	610	1365	940	1400	230	75	310	250	627	M24	359	E1
80-200/370/W	80	100	125	550	610	1365	940	1400	230	75	310	250	627	M24	375	E1
80-250/450/W	80	100	125	550	610	1454	940	1400	230	90	365	280	749	M24	549	E1
80-250/550/W	80	100	125	600	660	1563	1060	1600	270	90	390	280	792	M24	702	F1
80-250/750/W	80	100	125	670	730	1670	1200	1800	300	90	420	280	892	M24	979	G1