

50 Hz



e-NSC Series

HORIZONTAL CENTRIFUGAL ELECTRIC PUMPS
EQUIPPED WITH **IE3** MOTORS

ErP 2009/125/EC

e-NSC 65, 80 SERIES HYDRAULIC PERFORMANCE RANGE AT 50 Hz, 4 POLES

PUMP TYPE	P _N kW	Ø Impeller (mm)				Q = DELIVERY												
		STD (1)	B (2)	O (3)	η _p %	l/s	3,3	6,3	9,3	12,2	15,2	18,2	21,2	24,2	27,2	30,1	33,1	36,1
						m ³ /h	0	12	23	33	44	55	66	76	87	98	109	119
H = TOTAL HEAD METRES COLUMN OF WATER																		
65-125/05	0,55	113	112	○	75,0	3,5		3,4	3,1	2,7	2,1							
65-125/07	0,75	127	126	○	77,0	4,9		4,7	4,4	3,9	3,2	2,4						
65-125/11	1,1	137	136	○	78,3	5,8		5,8	5,6	5,1	4,5	3,6	2,7					
65-125/15	1,5	148	146	●	79,5	7,2		7,1	6,9	6,5	6,0	5,4	4,6	3,6				
65-160/11A	1,1	145	144	○	77,1	6,4		6,4	6,0	5,4	4,4	3,4						
65-160/15B	1,5	145	144	○	77,1	6,4		6,4	6,0	5,4	4,4	3,4						
65-160/11	1,1	151	152	○	78,0	7,2		7,0	6,7	6,1	5,2	4,1						
65-160/15A	1,5	151	152	○	78,0	7,2		7,0	6,7	6,1	5,2	4,1						
65-160/15	1,5	159	160	○	79,6	8,2		8,0	7,7	7,1	6,3	5,3						
65-160/22A	2,2	175	176	○	81,8	10,2		10,1	9,9	9,4	8,8	7,9	6,8	5,6				
65-160/22	2,2	180	180	●	82,1	10,9		10,8	10,5	10,0	9,3	8,4	7,4	6,1				
65-200/15	1,5	165	162	○	73,1	8,9	8,9	8,7	8,2	7,2	5,7							
65-200/22A	2,2	177	177	○	74,6	10,6		10,5	10,0	9,2	7,8	6,0						
65-200/22	2,2	189	189	○	76,9	12,1		12,0	11,6	10,8	9,6	7,9	5,7					
65-200/30	3	199	199	○	78,0	13,6		13,6	13,2	12,6	11,5	9,9	7,8					
65-200/40	4	220	218	●	80,0	17,0		16,9	16,7	16,1	15,3	14,1	12,5	10,3				
65-250/30	3	195	192	○	73,9	12,6		13,2	12,8	12,0	10,8	9,3	7,3					
65-250/40	4	215	213	○	74,3	15,7		16,2	15,8	15,1	14,1	12,7	11,0	8,9				
65-250/55A	5,5	229	226	○	76,0	18,1		19,0	18,7	18,1	17,3	16,1	14,6	12,8	10,5			
65-250/55	5,5	243	240	○	77,2	20,7		21,3	21,2	20,7	20,0	18,9	17,5	15,8	13,7			
65-250/75	7,5	258	255	●	77,6	24,3		24,6	24,3	23,8	23,0	22,0	20,8	19,2	17,4	15,2		
65-315/55	5,5	260	260	○	68,1	22,7		22,4	21,7	20,8	19,6	18,0	15,7	12,7				
65-315/75	7,5	285	285	○	70,4	27,6		27,3	26,8	26,0	24,8	23,3	21,4	18,9	15,9			
65-315/110	11	315	315	○	71,4	34,7		34,5	34,0	33,3	32,3	31,0	29,3	27,2	24,6	21,4	17,3	
65-315/150	15	334	334	●	72,2	39,0		38,9	38,5	37,8	36,8	35,5	33,9	32,0	29,7	27,0	23,8	20,3

PUMP TYPE	P _N kW	Ø Impeller (mm)				Q = DELIVERY												
		STD (1)	B (2)	O (3)	η _p %	l/s	5,6	10,7	15,7	20,8	25,8	30,9	35,9	40,9	46,0	51,0	56,1	61,1
						m ³ /h	0	20	38	57	75	93	111	129	147	166	184	202
H = TOTAL HEAD METRES COLUMN OF WATER																		
80-160/15	1,5	144	144	○	72,1	6,5		6,2	5,5	4,5	3,5							
80-160/22A	2,2	158	158	○	78,4	8,3		7,9	7,3	6,5	5,4	4,2						
80-160/22	2,2	168	168	○	79,0	9,3		9,0	8,5	7,6	6,5	5,2	3,8					
80-160/30	3	177	177	●	81,2	10,5		10,2	9,8	9,0	8,0	6,7	5,3					
80-200/30	3	181	177	○	77,1	10,8		10,6	10,1	9,3	8,2							
80-200/40	4	195	192	○	79,7	12,8		12,7	12,4	11,6	10,4	8,9						
80-200/55A	5,5	208	204	○	82,0	15,0		14,9	14,5	13,9	12,8	11,3						
80-200/55	5,5	219	216	●	82,5	16,9		16,5	16,2	15,6	14,7	13,5	11,8					
80-250/55A	5,5	214	211	○	80,0	16,4		16,0	15,4	14,4	13,1	11,3	9,1	6,5				
80-250/55	5,5	227	224	○	80,1	18,2		18,2	17,6	16,6	15,3	13,5						
80-250/75	7,5	241	238	○	80,8	21,0		20,7	20,2	19,4	18,1	16,4	14,4					
80-250/110	11	259	256	●	82,2	24,1		23,9	23,7	23,2	22,2	20,8	19,0	16,7				
80-315/110A	11	262	262	○	75,8	23,1		23,1	22,7	21,9	20,4	18,4	15,8	12,8	9,6			
80-315/110	11	280	280	○	76,0	26,6		26,6	26,4	25,7	24,5	22,8	20,4	17,5				
80-315/150	15	304	304	○	76,9	31,6		31,7	31,6	31,2	30,3	28,9	26,8	24,3	21,2			
80-315/185	18,5	321	321	○	77,2	35,5		35,6	35,5	35,2	34,4	33,2	31,4	29,1	26,2	22,7		
80-315/220	22	334	334	●	77,8	38,6		38,7	38,6	38,3	37,6	36,4	34,8	32,7	30,0	26,7		
80-400/185	18,5	338	338	○	69,9	39,1		39,0	38,2	37,0	35,3	33,3	30,6	27,0	22,0	15,0	5,1	
80-400/220	22	356	356	○	71,3	43,8	44,0	43,8	43,2	42,0	40,4	38,4	36,1	33,1	29,1			
80-400/300	30	388	388	○	72,5	53,1		52,8	52,6	51,7	50,2	48,3	46,1	43,7	40,8			
80-400/370	37	418	418	●	73,8	62,6		61,9	61,7	61,0	59,7	57,9	55,9	53,5	50,9	47,8		

Hydraulic performances in compliance with ISO 9906:2012 - Grade 3B (ex ISO 9906:1999 - Annex A)

Nsc-65-80_4p50-en_d_th

(1) STD = Cast iron/Stainless steel - B = Bronze (2) ● = Full impeller diameter - ○ = Trimmed impeller diameter (3) Hydraulic efficiency of pump.

e-NSC SERIES
OPERATING CHARACTERISTICS AT 50 Hz, 4 POLES

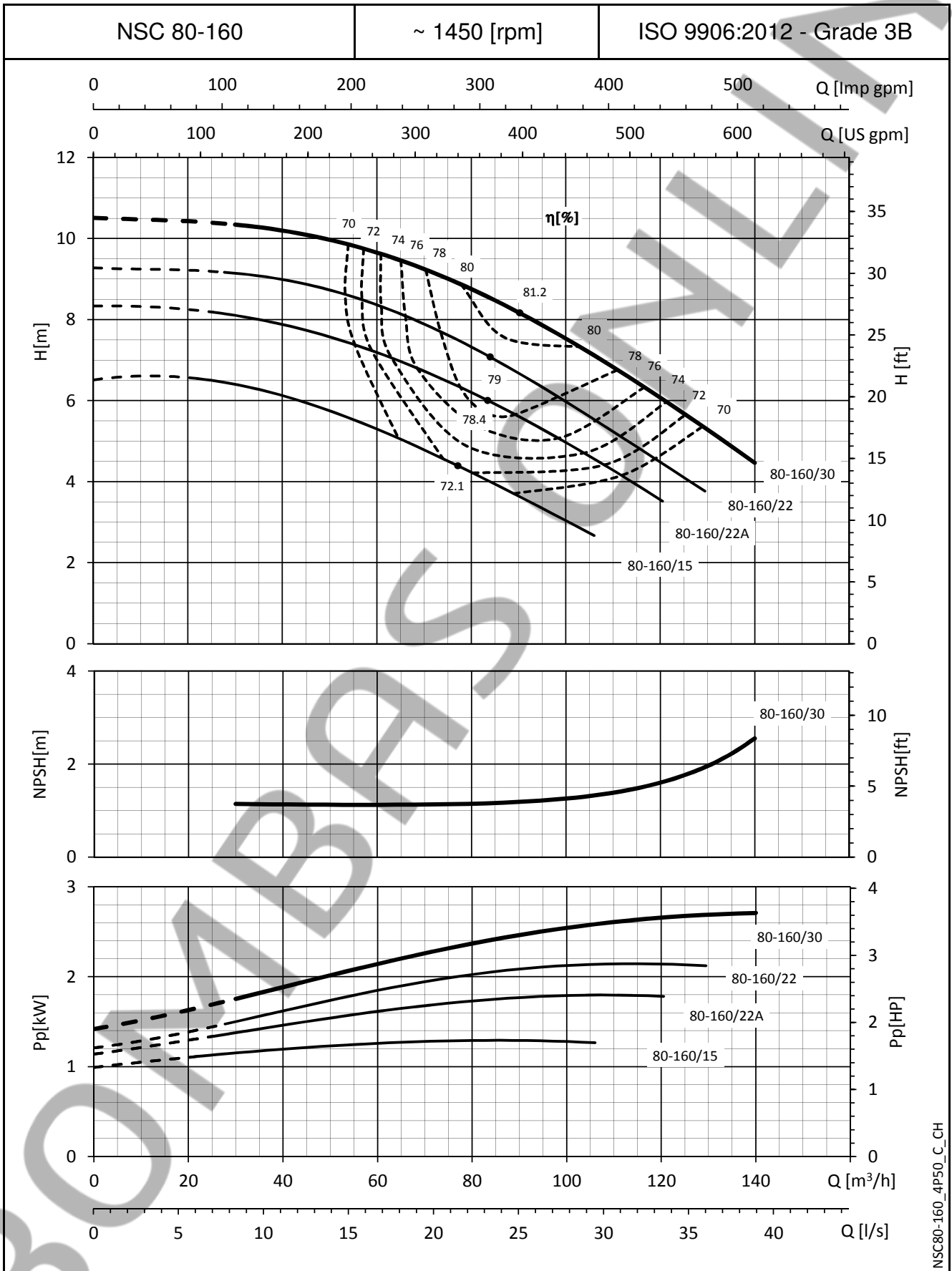

NSC80-160_4P50_C_CH

The NPSH values are laboratory values; for practical use we suggest increasing these values by 0,5 m.
These performances are valid for liquids with density $\rho = 1,0 \text{ Kg/dm}^3$ and kinematic viscosity $\nu = 1 \text{ mm}^2/\text{sec}$.

e-NSC SERIES
OPERATING CHARACTERISTICS AT 50 Hz, 4 POLES

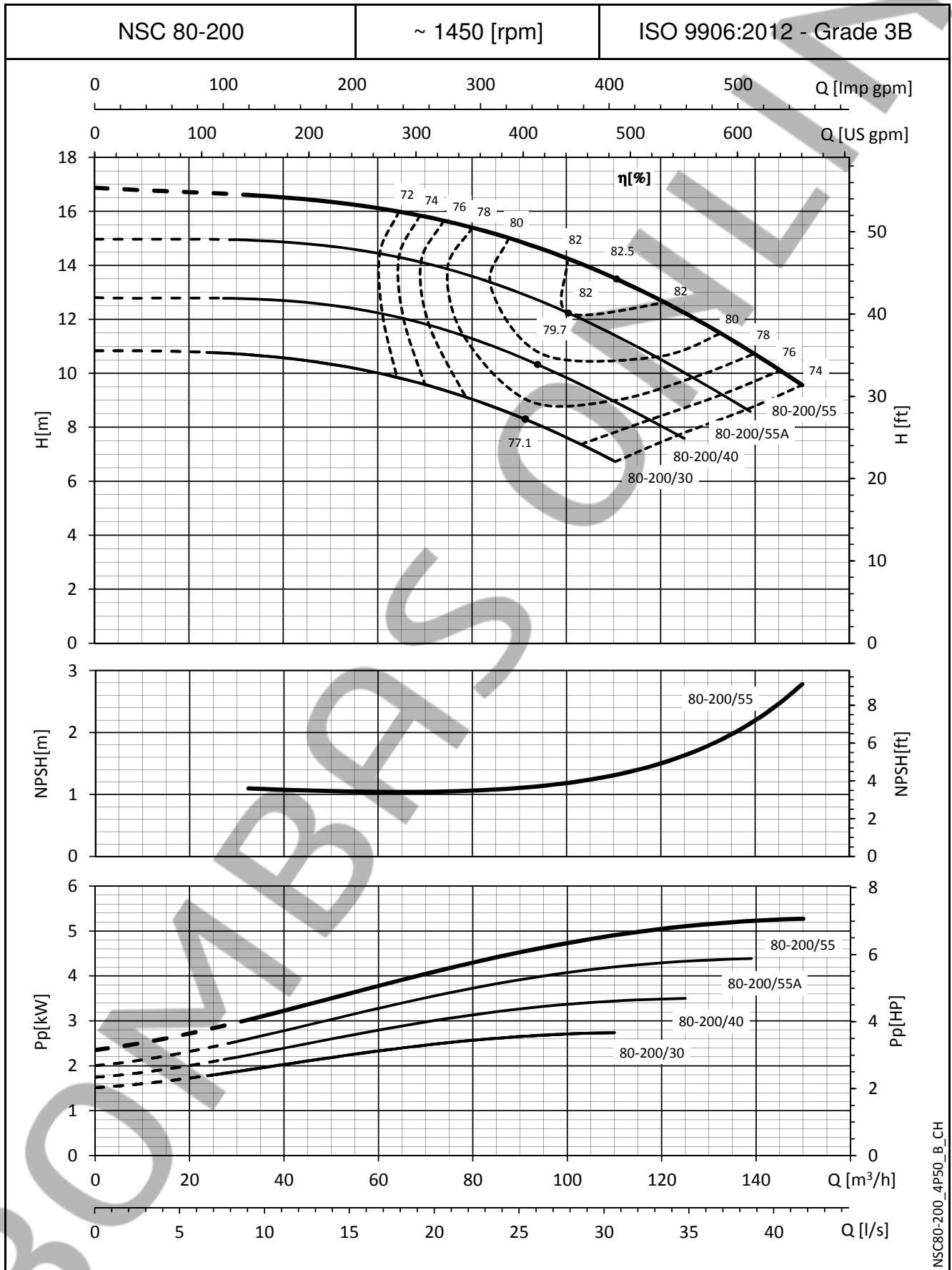

NSC80-200_4P50_B_CH

The NPSH values are laboratory values; for practical use we suggest increasing these values by 0,5 m.
These performances are valid for liquids with density $\rho = 1,0 \text{ Kg/dm}^3$ and kinematic viscosity $\nu = 1 \text{ mm}^2/\text{sec}$.

e-NSC SERIES
OPERATING CHARACTERISTICS AT 50 Hz, 4 POLES

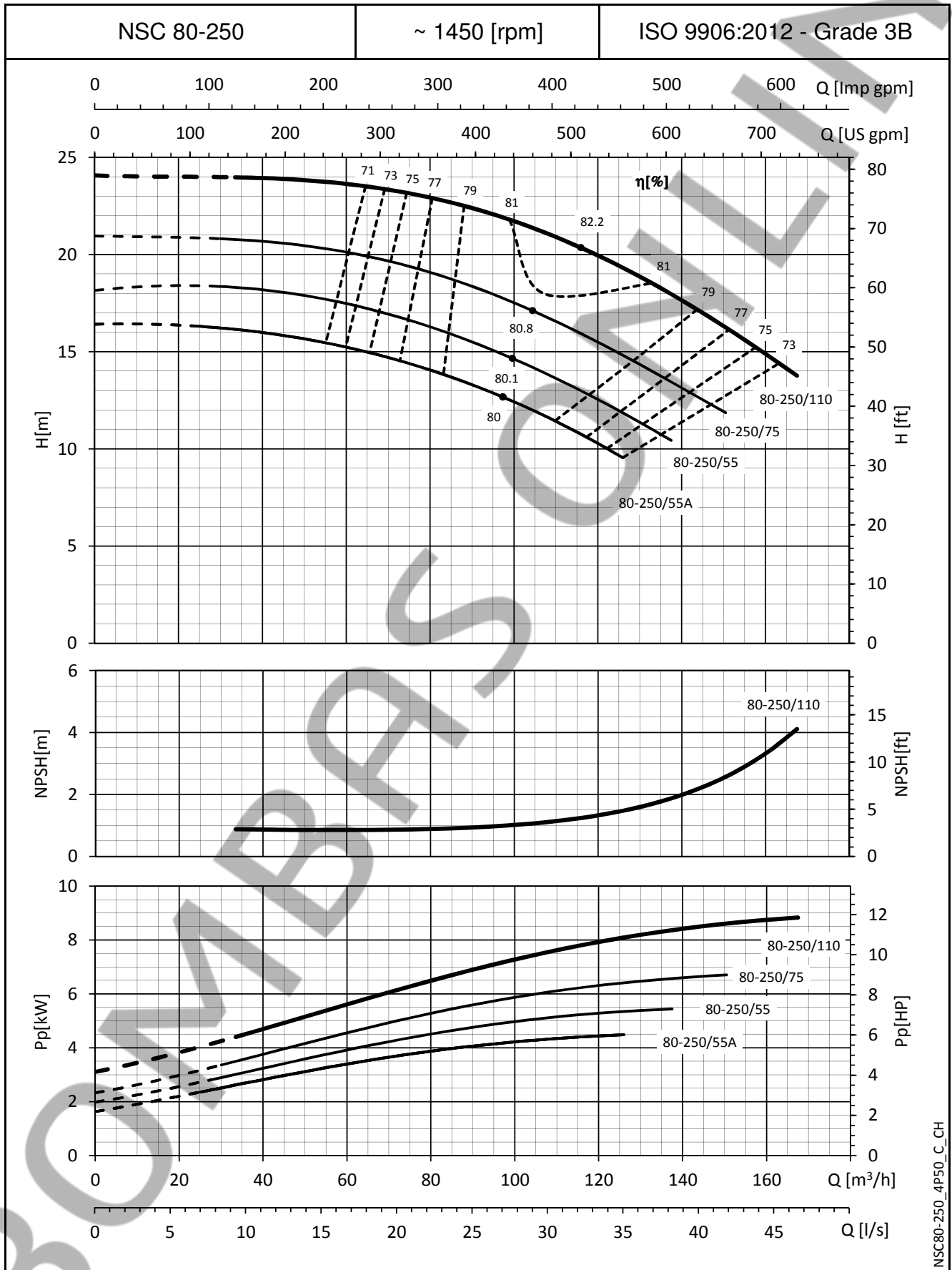

NSC80-250_4P50_C_CH

The NPSH values are laboratory values; for practical use we suggest increasing these values by 0,5 m.
These performances are valid for liquids with density $\rho = 1,0 \text{ Kg/dm}^3$ and kinematic viscosity $\nu = 1 \text{ mm}^2/\text{sec}$.

e-NSC SERIES
OPERATING CHARACTERISTICS AT 50 Hz, 4 POLES

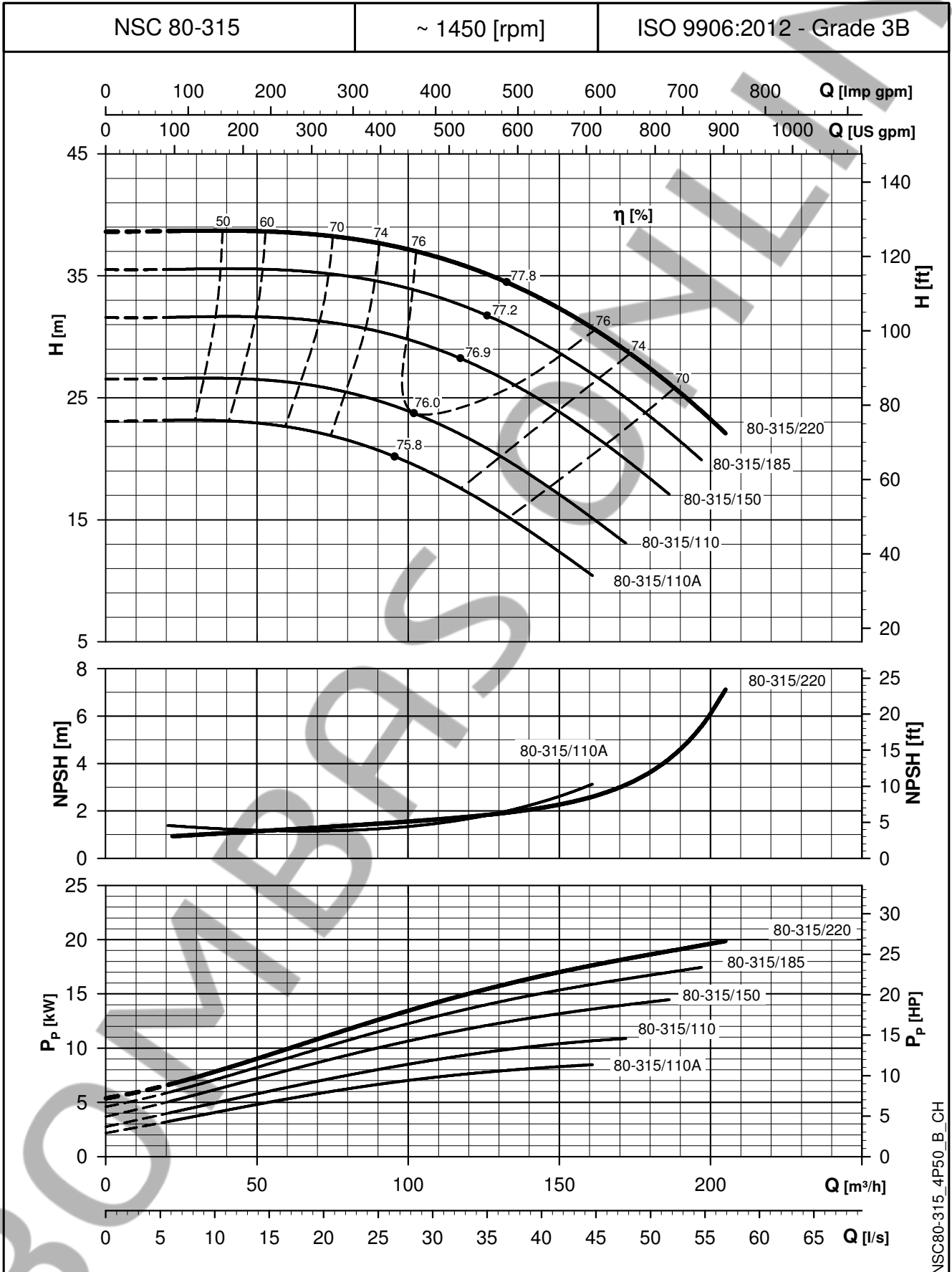

NSC80-315_4P50_B_CH

The NPSH values are laboratory values; for practical use we suggest increasing these values by 0,5 m.
These performances are valid for liquids with density $\rho = 1,0 \text{ Kg/dm}^3$ and kinematic viscosity $\nu = 1 \text{ mm}^2/\text{sec}$.

e-NSC SERIES
OPERATING CHARACTERISTICS AT 50 Hz, 4 POLES

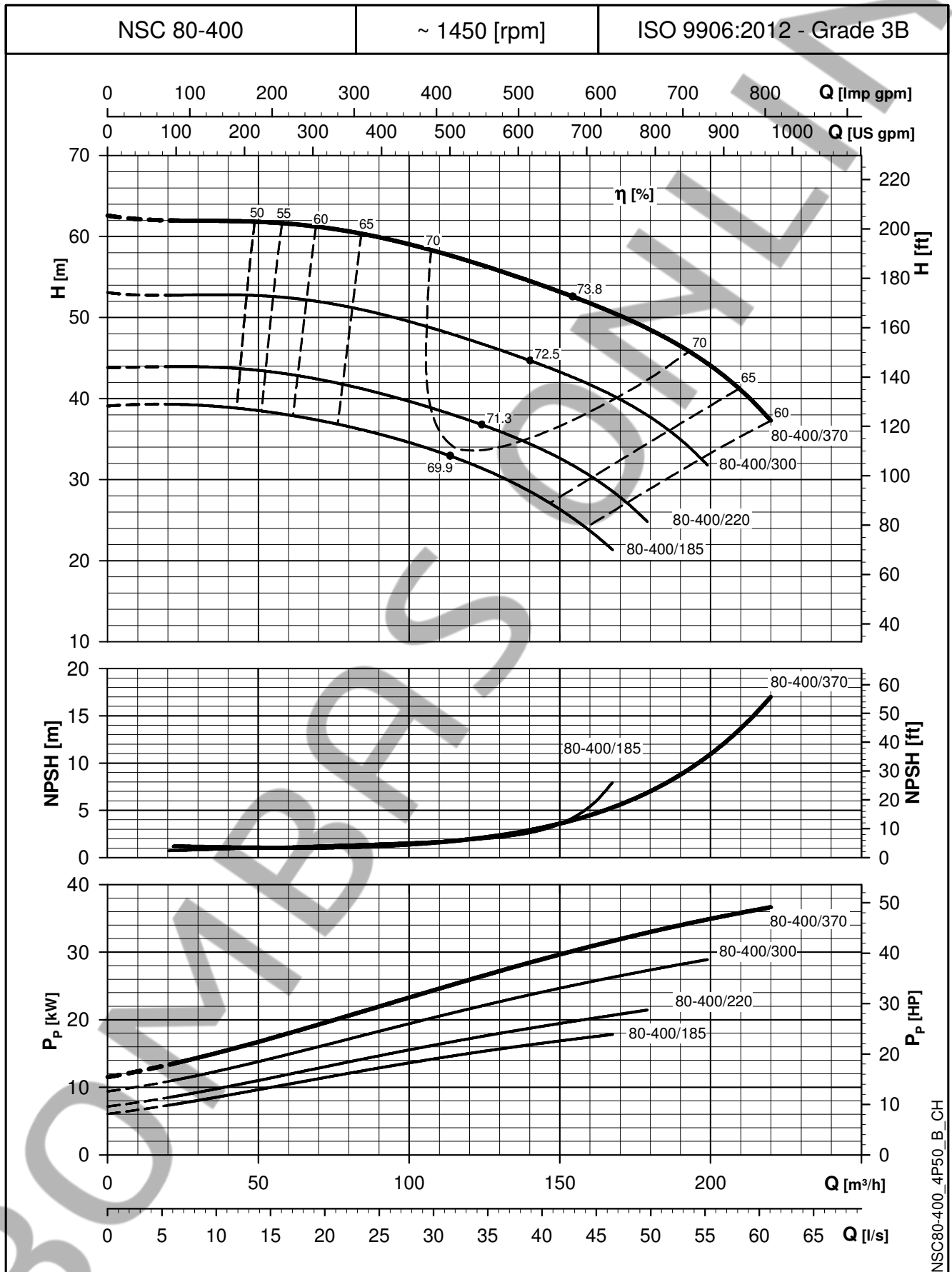

The NPSH values are laboratory values; for practical use we suggest increasing these values by 0,5 m.
These performances are valid for liquids with density $\rho = 1,0 \text{ Kg/dm}^3$ and kinematic viscosity $\nu = 1 \text{ mm}^2/\text{sec}$.

**NSCF 80, 100, 125 SERIES (MOUNTED ON BASE)
DIMENSIONS AND WEIGHTS AT 50 Hz, 4 POLES**

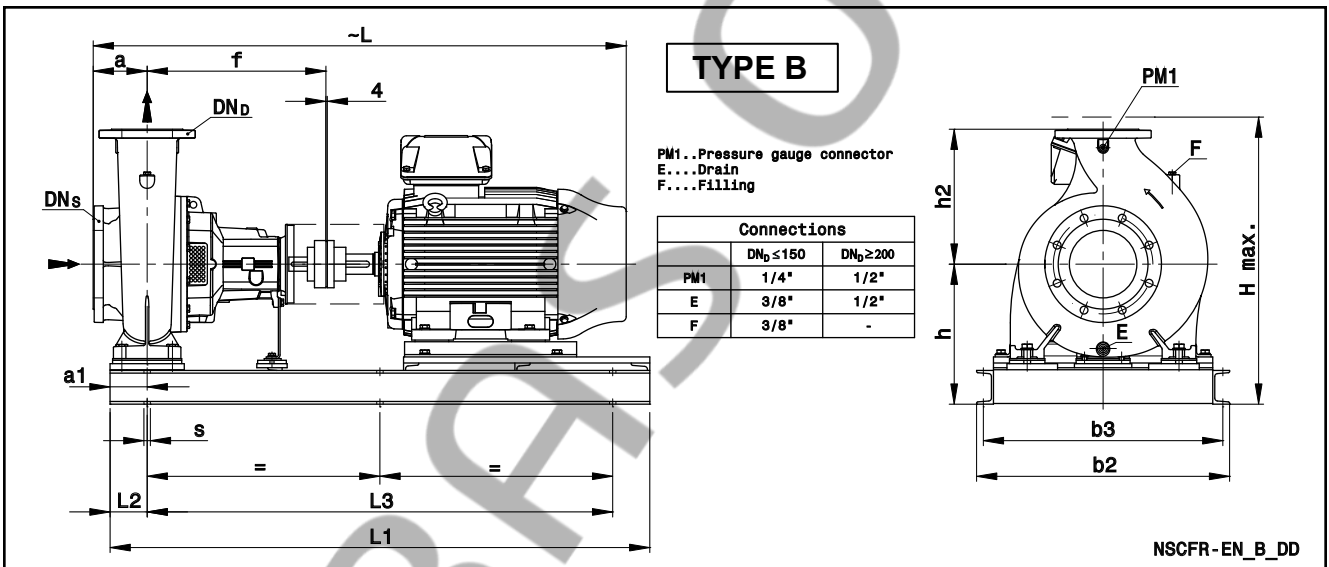
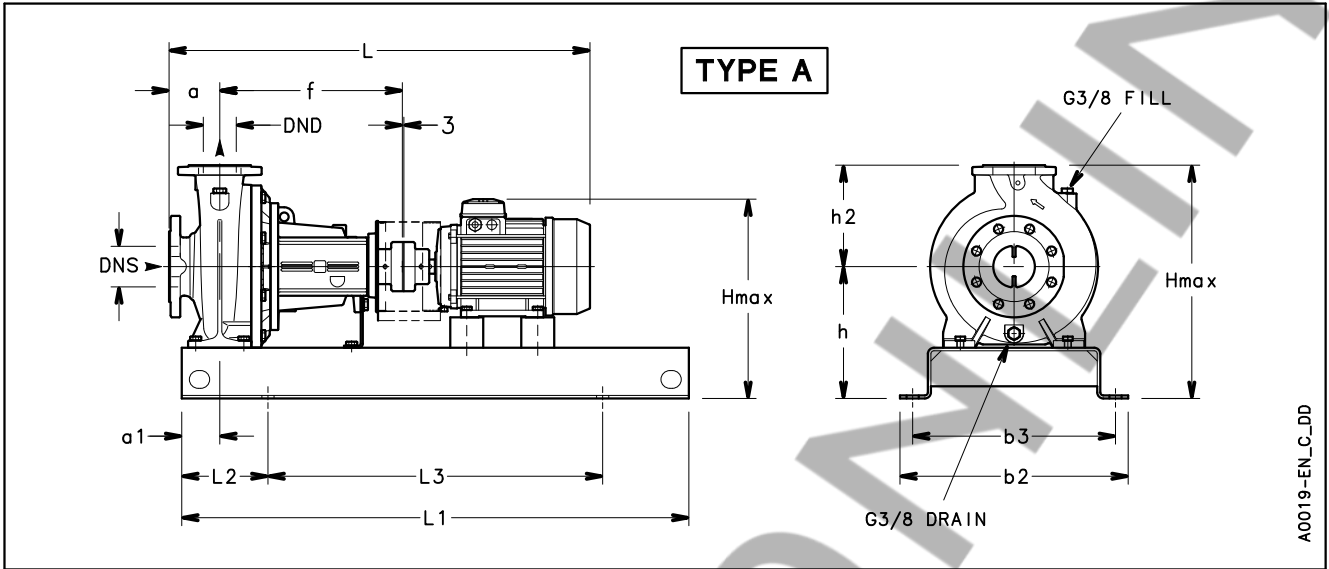

NSCF 80, 100, 125 SERIES (MOUNTED ON BASE) DIMENSIONS AND WEIGHTS AT 50 Hz, 4 POLES

PUMP TYPE NSCF..4	TYPE	DIMENSIONS (mm)															WEIGHT (kg) G	COUPLING TYPE
		DNS	DND	a	a1	b2	b3	f	h	h2	L	L1	L3	L2	H max	s FOR SCREWS		
80-160/15/P	A	100	80	125	75	450	400	360	280	225	836	1000	170	660	505	4xØ24 (M20)	124	B68C
80-160/22A/P	A	100	80	125	75	490	440	360	280	225	913	1120	190	740	505	4xØ24 (M20)	140	B80A
80-160/22/P	A	100	80	125	75	490	440	360	280	225	913	1120	190	740	505	4xØ24 (M20)	140	B80A
80-160/30/P	A	100	80	125	75	490	440	360	280	225	931	1120	190	740	505	4xØ24 (M20)	145	B80A
80-200/30/P	A	100	80	125	75	490	440	470	280	250	1041	1120	190	740	530	4xØ24 (M20)	162	B95C
80-200/40/P	A	100	80	125	75	490	440	470	280	250	1041	1120	190	740	530	4xØ24 (M20)	182	B95C
80-200/55A/P	A	100	80	125	75	490	440	470	280	250	1083	1120	190	740	530	4xØ24 (M20)	191	B95D
80-200/55/P	A	100	80	125	75	490	440	470	280	250	1083	1120	190	740	530	4xØ24 (M20)	191	B95D
80-250/55A/P	A	100	80	125	90	540	490	470	310	280	1083	1250	205	840	590	4xØ24 (M20)	200	B95D
80-250/55/P	A	100	80	125	90	540	490	470	310	280	1083	1250	205	840	590	4xØ24 (M20)	200	B95D
80-250/75/P	A	100	80	125	90	540	490	470	310	280	1083	1250	205	840	590	4xØ24 (M20)	204	B95D
80-250/110/P	A	100	80	125	90	540	490	470	310	280	1202	1250	205	840	590	4xØ24 (M20)	259	B95E
80-315/110A/P	B	100	80	125	110	670	630	470	365	315	1203	1330	1110	110	680	6xØ19 (M16)	306	B95E
80-315/110/P	B	100	80	125	110	670	630	470	365	315	1203	1330	1110	110	680	6xØ19 (M16)	306	B95E
80-315/150/P	B	100	80	125	110	670	630	470	365	315	1203	1330	1110	110	680	6xØ19 (M16)	351	B110E
80-315/185/W	B	100	80	125	110	670	630	470	385	315	1263	1330	1110	110	700	6xØ19 (M16)	410	B110B
80-315/220/W	B	100	80	125	110	670	630	470	385	315	1301	1330	1110	110	700	6xØ19 (M16)	428	B110B
80-400/185/W	B	100	80	125	110	670	630	530	400	355	1323	1430	1210	110	755	6xØ19 (M16)	443	B110D
80-400/220/W	B	100	80	125	110	670	630	530	400	355	1361	1430	1210	110	755	6xØ19 (M16)	461	B110D
80-400/300/W	B	100	80	125	110	670	630	530	420	355	1426	1430	1210	110	775	6xØ19 (M16)	514	B125C
80-400/370/W	B	100	80	125	110	750	710	530	415	355	1545	1600	1380	110	799	6xØ19 (M16)	703	B140B
100-160/22A/P	B	125	100	125	110	670	630	470	355	280	1024	1100	880	110	635	6xØ19 (M16)	217	B95C
100-160/22/P	B	125	100	125	110	670	630	470	355	280	1024	1100	880	110	635	6xØ19 (M16)	217	B95C
100-160/30/P	B	125	100	125	110	670	630	470	355	280	1041	1100	880	110	635	6xØ19 (M16)	220	B95C
100-160/40/P	B	125	100	125	110	670	630	470	365	280	1041	1100	880	110	645	6xØ19 (M16)	241	B95C
100-200/40/P	B	125	100	125	110	670	630	470	365	280	1041	1100	880	110	645	6xØ19 (M16)	249	B95C
100-200/55/P	B	125	100	125	110	670	630	470	385	280	1084	1100	880	110	665	6xØ19 (M16)	261	B95D
100-200/75/P	B	125	100	125	110	670	630	470	385	280	1084	1100	880	110	665	6xØ19 (M16)	261	B95D
100-250/55/P	B	125	100	140	110	670	630	470	385	280	1099	1100	880	110	665	6xØ19 (M16)	263	B95D
100-250/75/P	B	125	100	140	110	670	630	470	385	280	1099	1100	880	110	665	6xØ19 (M16)	263	B95D
100-250/110/P	B	125	100	140	110	670	630	470	365	280	1218	1330	1110	110	645	6xØ19 (M16)	296	B95E
100-315/110/P	B	125	100	140	110	670	630	470	365	315	1218	1330	1110	110	680	6xØ19 (M16)	304	B95E
100-315/150/P	B	125	100	140	110	670	630	470	365	315	1218	1330	1110	110	680	6xØ19 (M16)	349	B110E
100-315/185/W	B	125	100	140	110	670	630	470	385	315	1278	1330	1110	110	700	6xØ19 (M16)	408	B110B
100-315/220/W	B	125	100	140	110	670	630	470	385	315	1316	1330	1110	110	700	6xØ19 (M16)	426	B110B
100-315/300/W	B	125	100	140	110	560	520	470	355	315	1381	1350	1130	110	672	6xØ19 (M16)	454	B125B
100-400/300/W	B	125	100	140	110	670	630	530	420	355	1441	1430	1210	110	775	6xØ19 (M16)	543	B125C
100-400/370/W	B	125	100	140	110	750	710	530	415	355	1560	1600	1380	110	799	6xØ19 (M16)	729	B140B
100-400/450/W	B	125	100	140	110	750	710	530	415	355	1560	1600	1380	110	799	6xØ19 (M16)	757	B140B
125-200/55/P	B	150	125	140	110	670	630	470	385	315	1099	1100	880	110	700	6xØ19 (M16)	268	B95D
125-200/75/P	B	150	125	140	110	670	630	470	385	315	1099	1100	880	110	700	6xØ19 (M16)	268	B95D
125-200/110/P	B	150	125	140	110	670	630	470	365	315	1218	1330	1110	110	680	6xØ19 (M16)	300	B95E
125-250/75/P	B	150	125	140	110	670	630	470	385	355	1099	1100	880	110	740	6xØ19 (M16)	268	B95D
125-250/110/P	B	150	125	140	110	670	630	470	365	355	1218	1330	1110	110	720	6xØ19 (M16)	300	B95E
125-250/150/P	B	150	125	140	110	670	630	470	365	355	1218	1330	1110	110	720	6xØ19 (M16)	345	B110E
125-315/185/W	B	150	125	140	110	670	630	530	400	355	1338	1430	1210	110	755	6xØ19 (M16)	444	B110D
125-315/220/W	B	150	125	140	110	670	630	530	400	355	1376	1430	1210	110	755	6xØ19 (M16)	462	B110D
125-315/300/W	B	150	125	140	110	670	630	530	420	355	1441	1430	1210	110	775	6xØ19 (M16)	517	B125C
125-315/370/W	B	150	125	140	110	750	710	530	415	355	1560	1600	1380	110	799	6xØ19 (M16)	703	B140B
125-400/370/W	B	150	125	140	110	750	710	530	440	400	1560	1600	1380	110	840	6xØ19 (M16)	753	B140B
125-400/450/W	B	150	125	140	110	750	710	530	440	400	1560	1600	1380	110	840	6xØ19 (M16)	781	B140B
125-400/550/W	B	150	125	140	110	750	710	530	440	400	1639	1600	1380	110	842	6xØ19 (M16)	865	B160B
125-400/750/W	B	150	125	140	110	750	710	530	440	400	1745	1600	1380	110	912	6xØ19 (M16)	1075	B180B

NOTE: Pumps with flanges according to EN 1092-2 as standard.

Nscf80-125_4p50-en_c_td

Available ASME B16.5 version on request. For flanges dimensions see drawing.