

50 Hz



e-NSC Series

HORIZONTAL CENTRIFUGAL ELECTRIC PUMPS
EQUIPPED WITH **IE3** MOTORS

ErP 2009/125/EC

e-NSC 65, 80 SERIES HYDRAULIC PERFORMANCE RANGE AT 50 Hz, 4 POLES

PUMP TYPE	P _N kW	Ø Impeller (mm)				Q = DELIVERY												
		STD (1)	B (2)	O (3)	η _p %	l/s	3,3	6,3	9,3	12,2	15,2	18,2	21,2	24,2	27,2	30,1	33,1	36,1
						m ³ /h	0	12	23	33	44	55	66	76	87	98	109	119
H = TOTAL HEAD METRES COLUMN OF WATER																		
65-125/05	0,55	113	112	○	75,0	3,5		3,4	3,1	2,7	2,1							
65-125/07	0,75	127	126	○	77,0	4,9		4,7	4,4	3,9	3,2	2,4						
65-125/11	1,1	137	136	○	78,3	5,8		5,8	5,6	5,1	4,5	3,6	2,7					
65-125/15	1,5	148	146	●	79,5	7,2		7,1	6,9	6,5	6,0	5,4	4,6	3,6				
65-160/11A	1,1	145	144	○	77,1	6,4		6,4	6,0	5,4	4,4	3,4						
65-160/15B	1,5	145	144	○	77,1	6,4		6,4	6,0	5,4	4,4	3,4						
65-160/11	1,1	151	152	○	78,0	7,2		7,0	6,7	6,1	5,2	4,1						
65-160/15A	1,5	151	152	○	78,0	7,2		7,0	6,7	6,1	5,2	4,1						
65-160/15	1,5	159	160	○	79,6	8,2		8,0	7,7	7,1	6,3	5,3						
65-160/22A	2,2	175	176	○	81,8	10,2		10,1	9,9	9,4	8,8	7,9	6,8	5,6				
65-160/22	2,2	180	180	●	82,1	10,9		10,8	10,5	10,0	9,3	8,4	7,4	6,1				
65-200/15	1,5	165	162	○	73,1	8,9	8,9	8,7	8,2	7,2	5,7							
65-200/22A	2,2	177	177	○	74,6	10,6		10,5	10,0	9,2	7,8	6,0						
65-200/22	2,2	189	189	○	76,9	12,1		12,0	11,6	10,8	9,6	7,9	5,7					
65-200/30	3	199	199	○	78,0	13,6		13,6	13,2	12,6	11,5	9,9	7,8					
65-200/40	4	220	218	●	80,0	17,0		16,9	16,7	16,1	15,3	14,1	12,5	10,3				
65-250/30	3	195	192	○	73,9	12,6		13,2	12,8	12,0	10,8	9,3	7,3					
65-250/40	4	215	213	○	74,3	15,7		16,2	15,8	15,1	14,1	12,7	11,0	8,9				
65-250/55A	5,5	229	226	○	76,0	18,1		19,0	18,7	18,1	17,3	16,1	14,6	12,8	10,5			
65-250/55	5,5	243	240	○	77,2	20,7		21,3	21,2	20,7	20,0	18,9	17,5	15,8	13,7			
65-250/75	7,5	258	255	●	77,6	24,3		24,6	24,3	23,8	23,0	22,0	20,8	19,2	17,4	15,2		
65-315/55	5,5	260	260	○	68,1	22,7		22,4	21,7	20,8	19,6	18,0	15,7	12,7				
65-315/75	7,5	285	285	○	70,4	27,6		27,3	26,8	26,0	24,8	23,3	21,4	18,9	15,9			
65-315/110	11	315	315	○	71,4	34,7		34,5	34,0	33,3	32,3	31,0	29,3	27,2	24,6	21,4	17,3	
65-315/150	15	334	334	●	72,2	39,0		38,9	38,5	37,8	36,8	35,5	33,9	32,0	29,7	27,0	23,8	20,3

PUMP TYPE	P _N kW	Ø Impeller (mm)				Q = DELIVERY												
		STD (1)	B (2)	O (3)	η _p %	l/s	5,6	10,7	15,7	20,8	25,8	30,9	35,9	40,9	46,0	51,0	56,1	61,1
						m ³ /h	0	20	38	57	75	93	111	129	147	166	184	202
H = TOTAL HEAD METRES COLUMN OF WATER																		
80-160/15	1,5	144	144	○	72,1	6,5		6,2	5,5	4,5	3,5							
80-160/22A	2,2	158	158	○	78,4	8,3		7,9	7,3	6,5	5,4	4,2						
80-160/22	2,2	168	168	○	79,0	9,3		9,0	8,5	7,6	6,5	5,2	3,8					
80-160/30	3	177	177	●	81,2	10,5		10,2	9,8	9,0	8,0	6,7	5,3					
80-200/30	3	181	177	○	77,1	10,8		10,6	10,1	9,3	8,2							
80-200/40	4	195	192	○	79,7	12,8		12,7	12,4	11,6	10,4	8,9						
80-200/55A	5,5	208	204	○	82,0	15,0		14,9	14,5	13,9	12,8	11,3						
80-200/55	5,5	219	216	●	82,5	16,9		16,5	16,2	15,6	14,7	13,5	11,8					
80-250/55A	5,5	214	211	○	80,0	16,4		16,0	15,4	14,4	13,1	11,3	9,1	6,5				
80-250/55	5,5	227	224	○	80,1	18,2		18,2	17,6	16,6	15,3	13,5						
80-250/75	7,5	241	238	○	80,8	21,0		20,7	20,2	19,4	18,1	16,4	14,4					
80-250/110	11	259	256	●	82,2	24,1		23,9	23,7	23,2	22,2	20,8	19,0	16,7				
80-315/110A	11	262	262	○	75,8	23,1		23,1	22,7	21,9	20,4	18,4	15,8	12,8	9,6			
80-315/110	11	280	280	○	76,0	26,6		26,6	26,4	25,7	24,5	22,8	20,4	17,5				
80-315/150	15	304	304	○	76,9	31,6		31,7	31,6	31,2	30,3	28,9	26,8	24,3	21,2			
80-315/185	18,5	321	321	○	77,2	35,5		35,6	35,5	35,2	34,4	33,2	31,4	29,1	26,2	22,7		
80-315/220	22	334	334	●	77,8	38,6		38,7	38,6	38,3	37,6	36,4	34,8	32,7	30,0	26,7		
80-400/185	18,5	338	338	○	69,9	39,1		39,0	38,2	37,0	35,3	33,3	30,6	27,0	22,0	15,0	5,1	
80-400/220	22	356	356	○	71,3	43,8	44,0	43,8	43,2	42,0	40,4	38,4	36,1	33,1	29,1			
80-400/300	30	388	388	○	72,5	53,1		52,8	52,6	51,7	50,2	48,3	46,1	43,7	40,8			
80-400/370	37	418	418	●	73,8	62,6		61,9	61,7	61,0	59,7	57,9	55,9	53,5	50,9	47,8		

Hydraulic performances in compliance with ISO 9906:2012 - Grade 3B (ex ISO 9906:1999 - Annex A)

Nsc-65-80_4p50-en_d_th

(1) STD = Cast iron/Stainless steel - B = Bronze (2) ● = Full impeller diameter - ○ = Trimmed impeller diameter (3) Hydraulic efficiency of pump.

e-NSC SERIES
OPERATING CHARACTERISTICS AT 50 Hz, 4 POLES

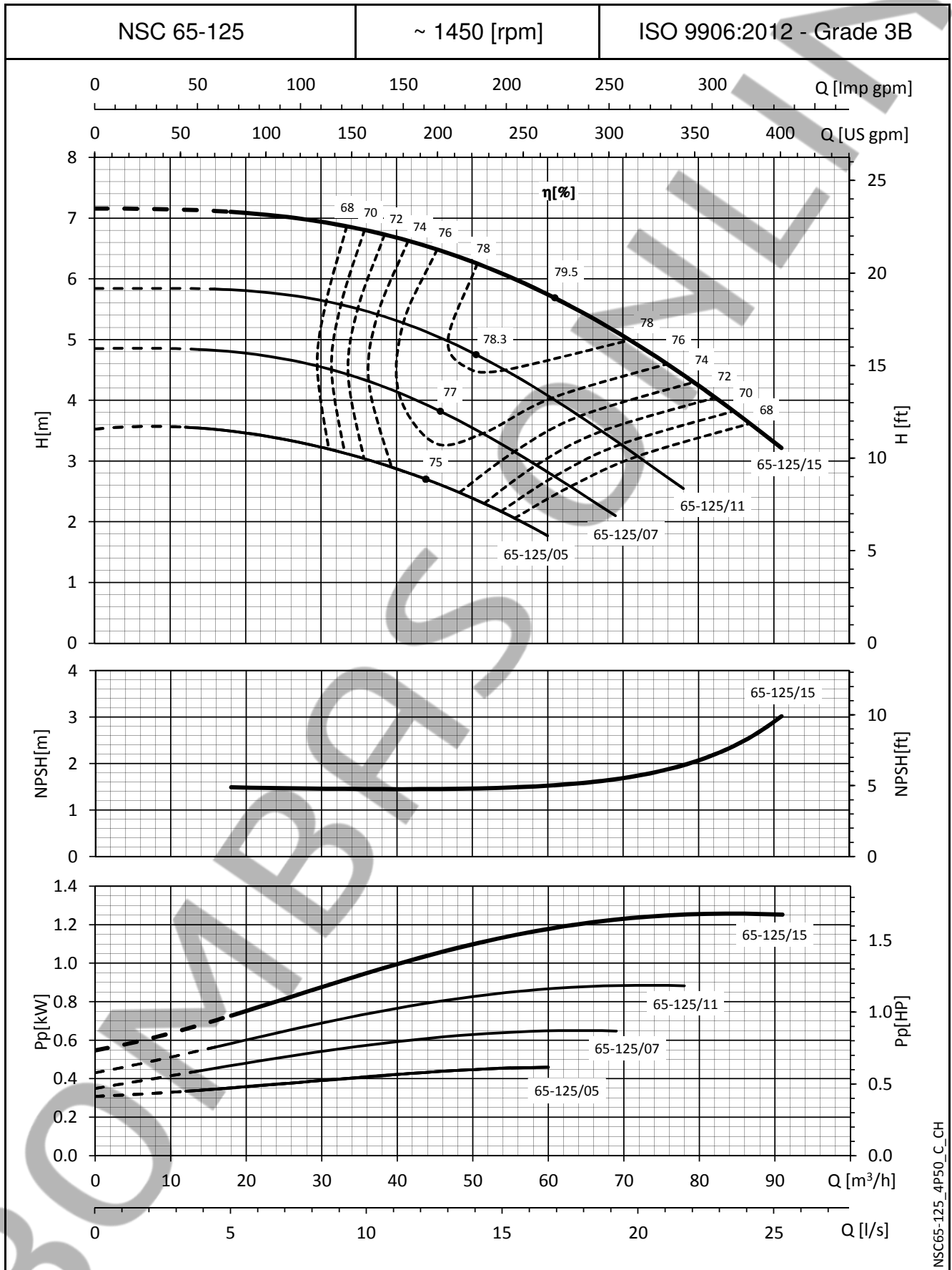

The NPSH values are laboratory values; for practical use we suggest increasing these values by 0,5 m.
These performances are valid for liquids with density $\rho = 1,0 \text{ Kg/dm}^3$ and kinematic viscosity $\nu = 1 \text{ mm}^2/\text{sec}$.

e-NSC SERIES
OPERATING CHARACTERISTICS AT 50 Hz, 4 POLES

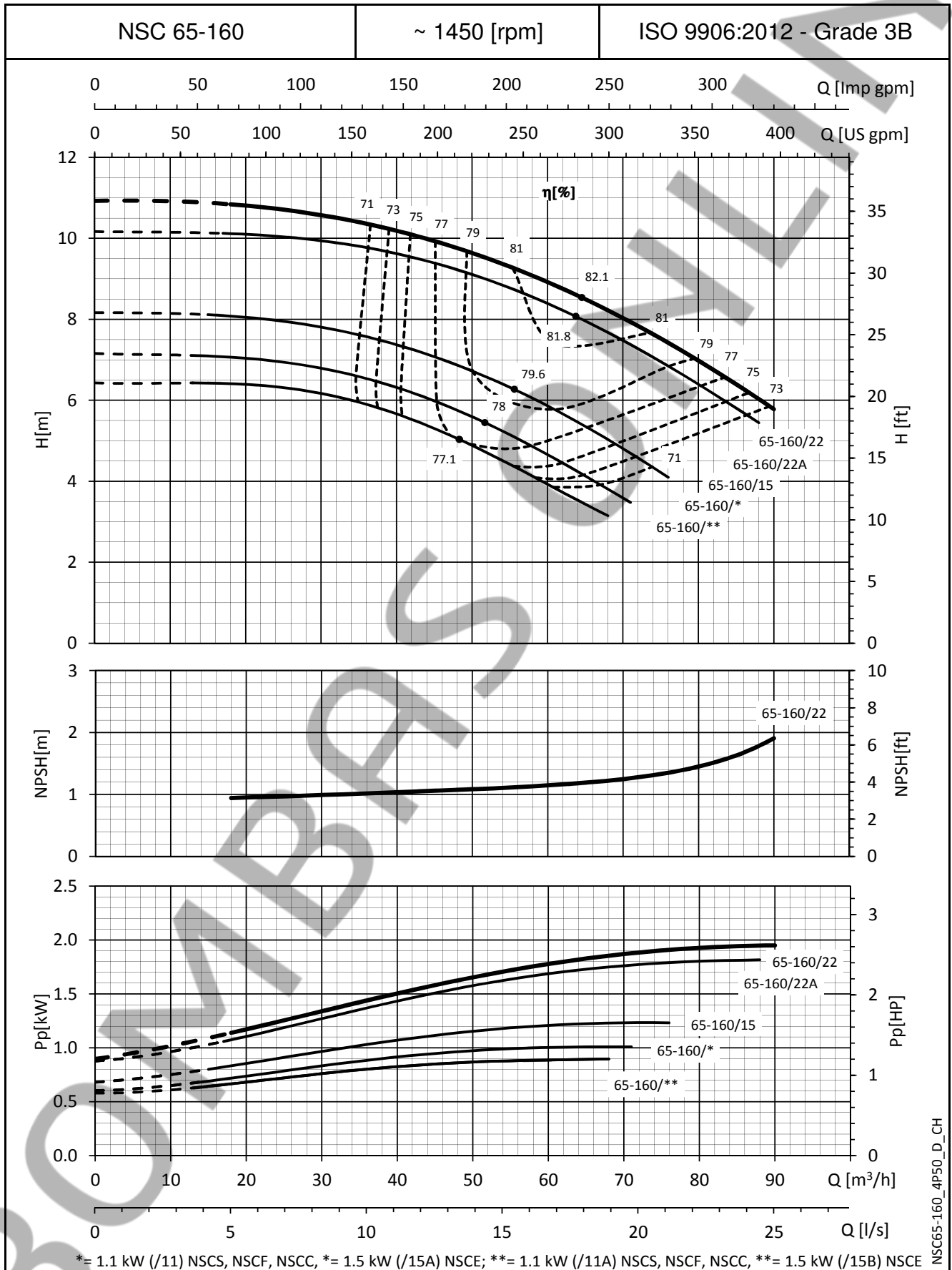

The NPSH values are laboratory values; for practical use we suggest increasing these values by 0,5 m.
 These performances are valid for liquids with density $\rho = 1,0 \text{ Kg/dm}^3$ and kinematic viscosity $\nu = 1 \text{ mm}^2/\text{sec}$.

e-NSC SERIES
OPERATING CHARACTERISTICS AT 50 Hz, 4 POLES

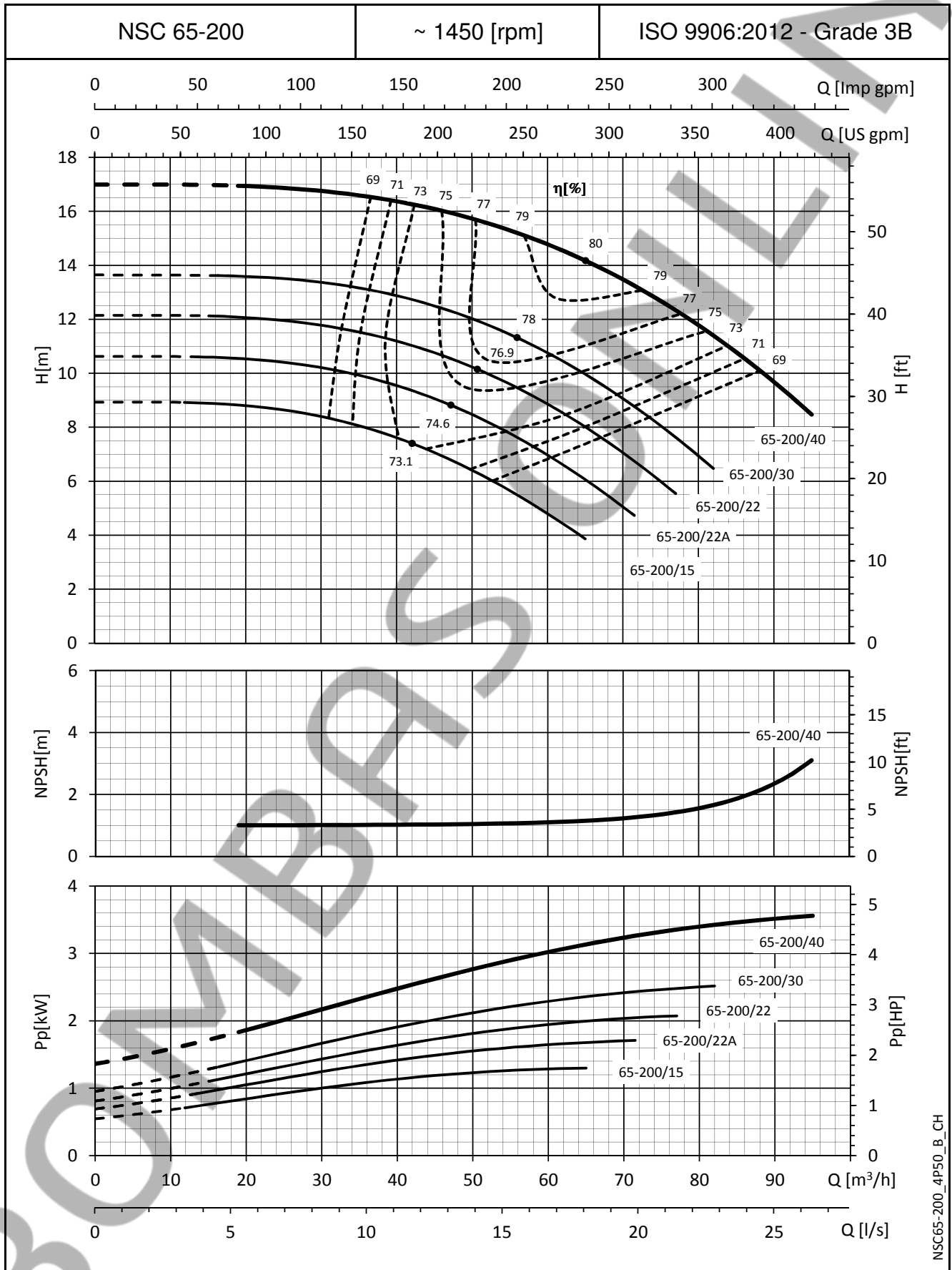

The NPSH values are laboratory values; for practical use we suggest increasing these values by 0,5 m.
These performances are valid for liquids with density $\rho = 1,0 \text{ Kg/dm}^3$ and kinematic viscosity $\nu = 1 \text{ mm}^2/\text{sec}$.

e-NSC SERIES
OPERATING CHARACTERISTICS AT 50 Hz, 4 POLES

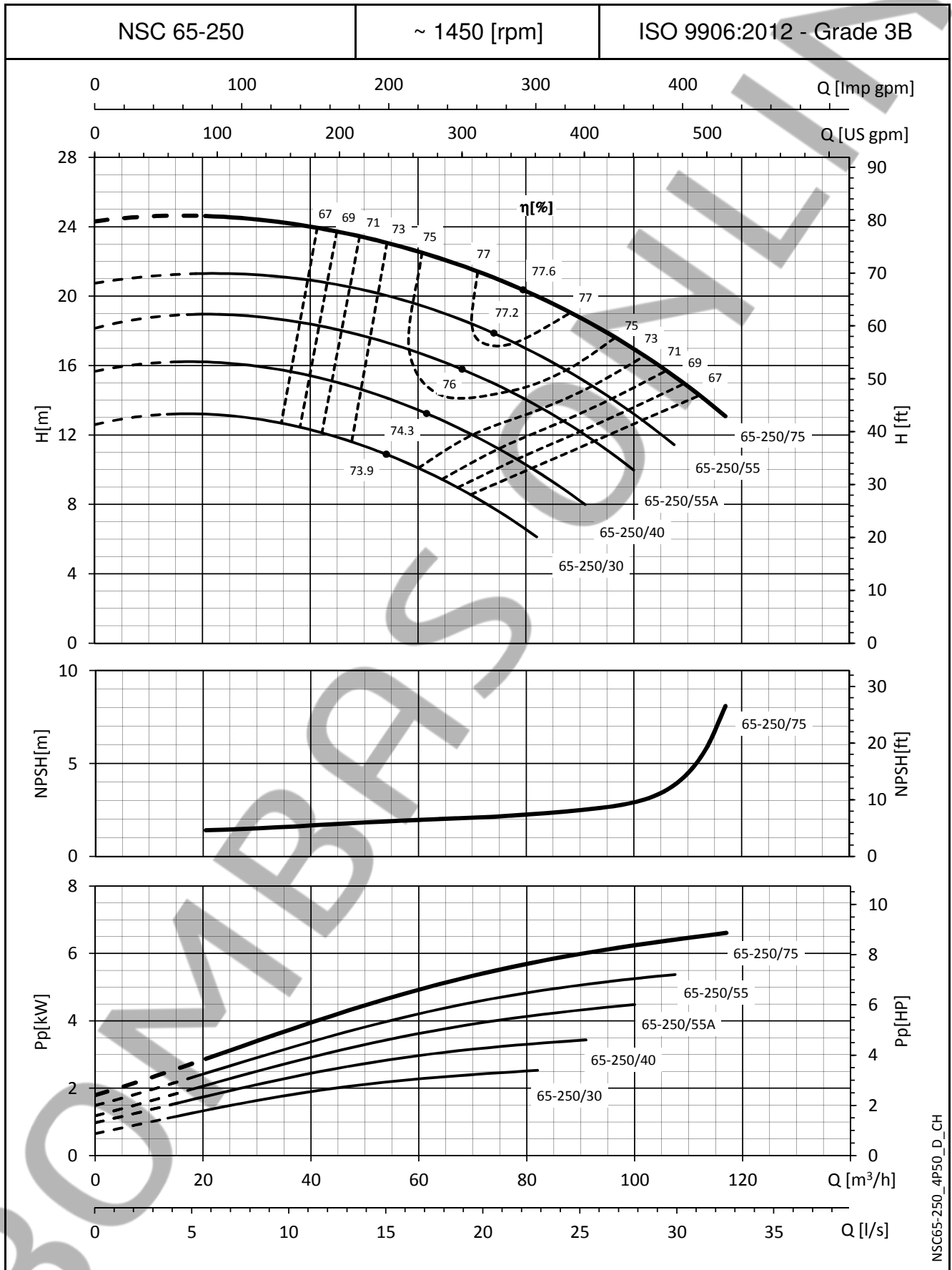

NSC65-250_4P50_D_CH

The NPSH values are laboratory values; for practical use we suggest increasing these values by 0,5 m.
These performances are valid for liquids with density $\rho = 1,0 \text{ Kg/dm}^3$ and kinematic viscosity $\nu = 1 \text{ mm}^2/\text{sec}$.

e-NSC SERIES
OPERATING CHARACTERISTICS AT 50 Hz, 4 POLES

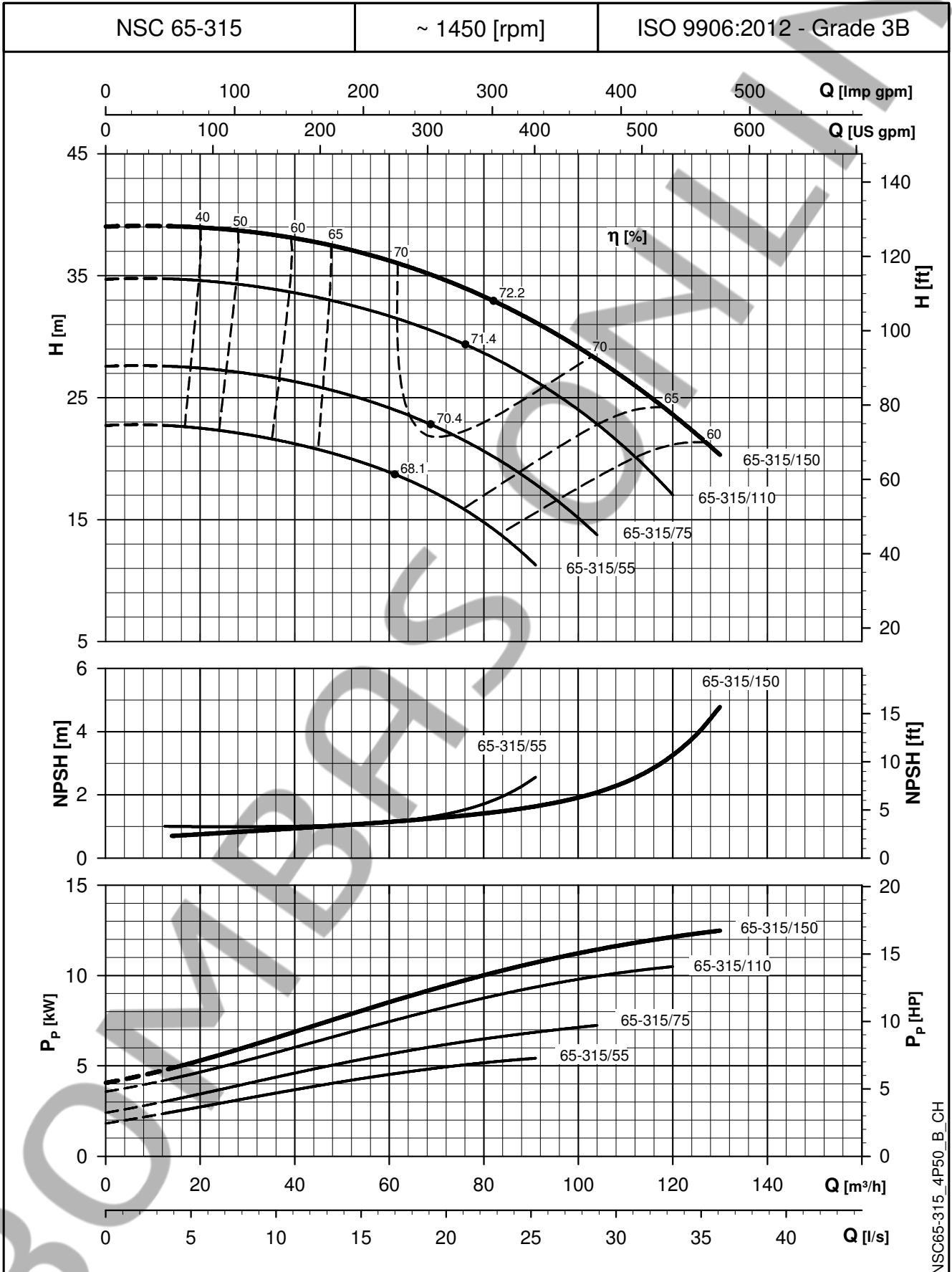

NSC65-315_4P50_B_CH

The NPSH values are laboratory values; for practical use we suggest increasing these values by 0,5 m.
These performances are valid for liquids with density $\rho = 1,0 \text{ Kg/dm}^3$ and kinematic viscosity $\nu = 1 \text{ mm}^2/\text{sec}$.

**NSCF 32 SERIES (MOUNTED ON BASE)
DIMENSIONS AND WEIGHTS AT 50 Hz, 4 POLES**

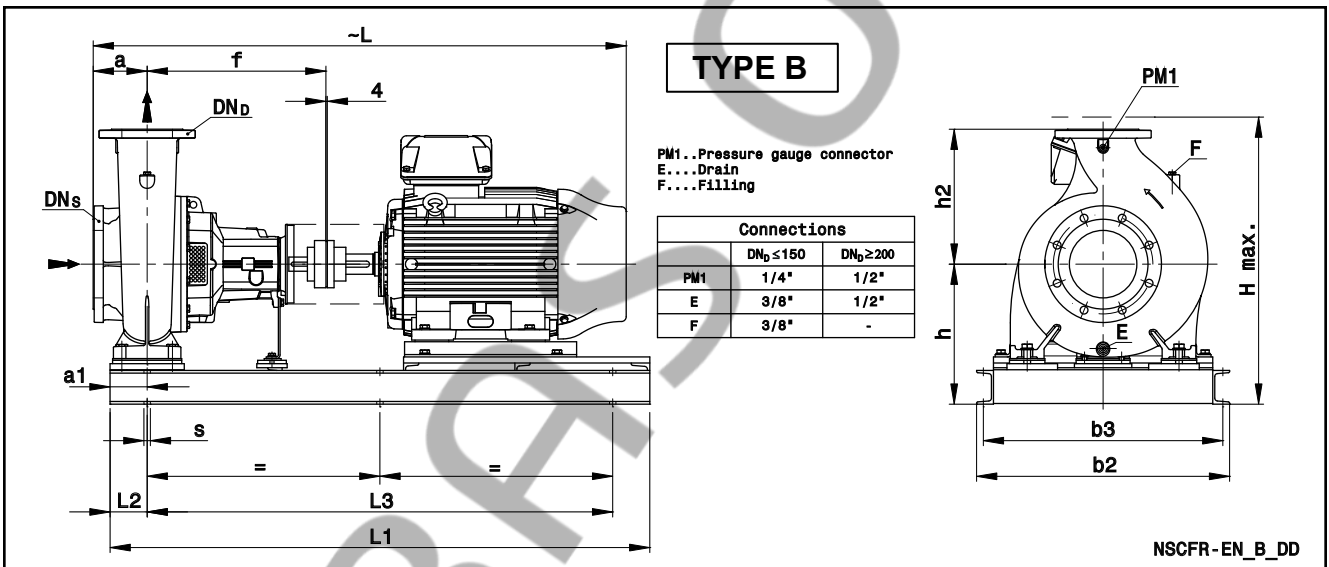
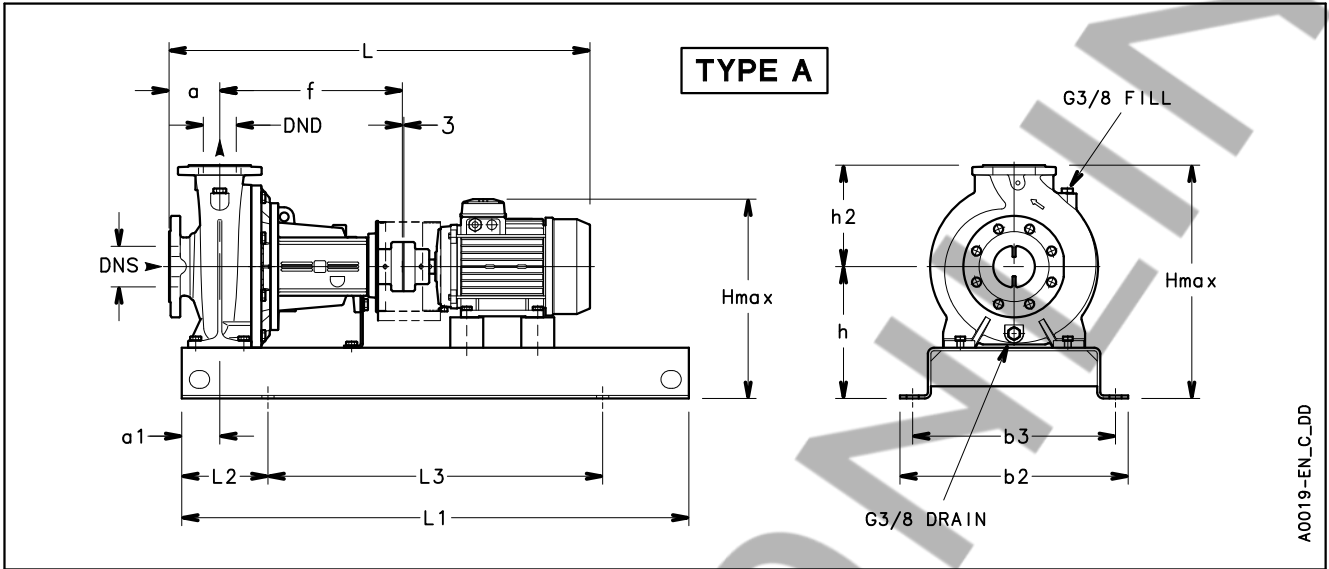

PUMP TYPE NSCF..4	TYPE	DIMENSIONS (mm)														H max	s FOR SCREWS	WEIGHT kg	COUPLING TYPE
		DN _S	DN _D	a	a1	b2	b3	f	h	h2	L	L1	L2	L3					
32-125/02B/S	A	50	32	80	60	360	320	360	212	140	704	800	130	540	352	4xØ19 (M16)	61	B68A	
32-125/02A/S	A	50	32	80	60	360	320	360	212	140	704	800	130	540	352	4xØ19 (M16)	61	B68A	
32-125/02/S	A	50	32	80	60	360	320	360	212	140	704	800	130	540	352	4xØ19 (M16)	61	B68A	
32-125/03/S	A	50	32	80	60	360	320	360	212	140	704	800	130	540	352	4xØ19 (M16)	62	B68A	
32-160/02/S	A	50	32	80	60	360	320	360	232	160	704	800	130	540	392	4xØ19 (M16)	62	B68A	
32-160/03/S	A	50	32	80	60	360	320	360	232	160	704	800	130	540	392	4xØ19 (M16)	63	B68A	
32-160/05A/S	A	50	32	80	60	360	320	360	232	160	746	800	130	540	392	4xØ19 (M16)	66	B68B	
32-160/05/S	A	50	32	80	60	360	320	360	232	160	746	800	130	540	392	4xØ19 (M16)	66	B68B	
32-200/05A/S	A	50	32	80	60	360	320	360	260	180	746	800	130	540	440	4xØ19 (M16)	73	B68B	
32-200/05/S	A	50	32	80	60	360	320	360	260	180	746	800	130	540	440	4xØ19 (M16)	73	B68B	
32-200/07/X	A	50	32	80	60	360	320	360	260	180	714	800	130	540	440	4xØ19 (M16)	76	B68B	
32-200/11/P	A	50	32	80	60	390	350	360	260	180	791	900	150	600	440	4xØ19 (M16)	85	B68C	
32-250/11A/P	A	50	32	100	75	450	400	360	280	225	811	1000	170	660	505	4xØ24 (M20)	112	B68C	
32-250/11/P	A	50	32	100	75	450	400	360	280	225	811	1000	170	660	505	4xØ24 (M20)	112	B68C	
32-250/15/P	A	50	32	100	75	450	400	360	280	225	811	1000	170	660	505	4xØ24 (M20)	117	B68C	
32-250/22/P	A	50	32	100	75	450	400	360	280	225	888	1000	170	660	505	4xØ24 (M20)	127	B80A	

NOTE: Pumps with flanges according to EN 1092-2 as standard.

Nscf32_4p50-en_c_td

Available ASME B16.5 version on request. For flanges dimensions see drawing.

NSCF 40, 50, 65 SERIES (MOUNTED ON BASE) DIMENSIONS AND WEIGHTS AT 50 Hz, 4 POLES

PUMP TYPE NSCF..4	TYPE	DIMENSIONS (mm)														WEIGHT kg	COUPLING TYPE	
		DNS	DND	a	a1	b2	b3	f	h	h2	L	L1	L2	L3	H max			S FOR SCREWS
40-125/02A/S	A	65	40	80	60	360	320	360	212	140	704	800	130	540	352	4xØ19 (M16)	62	B68A
40-125/02/S	A	65	40	80	60	360	320	360	212	140	704	800	130	540	352	4xØ19 (M16)	62	B68A
40-125/03/S	A	65	40	80	60	360	320	360	212	140	704	800	130	540	352	4xØ19 (M16)	63	B68A
40-125/05/S	A	65	40	80	60	360	320	360	212	140	746	800	130	540	352	4xØ19 (M16)	66	B68B
40-160/03/S	A	65	40	80	60	360	320	360	232	160	704	800	130	540	392	4xØ19 (M16)	64	B68A
40-160/05/S	A	65	40	80	60	360	320	360	232	160	746	800	130	540	392	4xØ19 (M16)	67	B68B
40-160/07/X	A	65	40	80	60	360	320	360	232	160	714	800	130	540	392	4xØ19 (M16)	70	B68B
40-160/11/P	A	65	40	80	60	390	350	360	232	160	791	900	150	600	392	4xØ19 (M16)	79	B68C
40-200/07/X	A	65	40	100	60	390	350	360	260	180	734	900	150	600	440	4xØ19 (M16)	81	B68B
40-200/11/P	A	65	40	100	60	390	350	360	260	180	811	900	150	600	440	4xØ19 (M16)	87	B68C
40-200/15A/P	A	65	40	100	60	390	350	360	260	180	811	900	150	600	440	4xØ19 (M16)	92	B68C
40-200/15/P	A	65	40	100	60	390	350	360	260	180	811	900	150	600	440	4xØ19 (M16)	92	B68C
40-250/11/P	A	65	40	100	75	450	400	360	280	225	811	1000	170	660	505	4xØ24 (M20)	113	B68C
40-250/15/P	A	65	40	100	75	450	400	360	280	225	811	1000	170	660	505	4xØ24 (M20)	118	B68C
40-250/22A/P	A	65	40	100	75	450	400	360	280	225	888	1000	170	660	505	4xØ24 (M20)	128	B80A
40-250/22/P	A	65	40	100	75	450	400	360	280	225	888	1000	170	660	505	4xØ24 (M20)	128	B80A
40-250/30/P	A	65	40	100	75	450	400	360	280	225	906	1000	170	660	505	4xØ24 (M20)	133	B80A
50-125/03/S	A	65	50	100	60	360	320	360	232	160	724	800	130	540	392	4xØ19 (M16)	66	B68A
50-125/05/S	A	65	50	100	60	360	320	360	232	160	766	800	130	540	392	4xØ19 (M16)	69	B68B
50-125/07/X	A	65	50	100	60	360	320	360	232	160	734	800	130	540	392	4xØ19 (M16)	72	B68B
50-125/11/P	A	65	50	100	60	390	350	360	232	160	811	900	150	600	392	4xØ19 (M16)	81	B68C
50-160/07/X	A	65	50	100	60	390	350	360	260	180	734	900	150	600	440	4xØ19 (M16)	82	B68B
50-160/11A/P	A	65	50	100	60	390	350	360	260	180	811	900	150	600	440	4xØ19 (M16)	88	B68C
50-160/11/P	A	65	50	100	60	390	350	360	260	180	811	900	150	600	440	4xØ19 (M16)	88	B68C
50-160/15/P	A	65	50	100	60	390	350	360	260	180	811	900	150	600	440	4xØ19 (M16)	93	B68C
50-200/11/P	A	65	50	100	60	390	350	360	260	200	811	900	150	600	460	4xØ19 (M16)	89	B68C
50-200/15/P	A	65	50	100	60	390	350	360	260	200	811	900	150	600	460	4xØ19 (M16)	94	B68C
50-200/22A/P	A	65	50	100	60	390	350	360	260	200	888	900	150	600	460	4xØ19 (M16)	104	B80A
50-200/22/P	A	65	50	100	60	390	350	360	260	200	888	900	150	600	460	4xØ19 (M16)	104	B80A
50-250/22A/P	A	65	50	100	75	450	400	360	280	225	888	1000	170	660	505	4xØ24 (M20)	129	B80A
50-250/22/P	A	65	50	100	75	450	400	360	280	225	888	1000	170	660	505	4xØ24 (M20)	129	B80A
50-250/30/P	A	65	50	100	75	450	400	360	280	225	906	1000	170	660	505	4xØ24 (M20)	134	B80A
50-250/40/P	A	65	50	100	75	450	400	360	280	225	906	1000	170	660	505	4xØ24 (M20)	153	B80A
50-315/40/P	B	65	50	125	110	670	630	470	365	280	1041	1100	110	880	645	6xØ19 (M16)	246,6	B95C
50-315/55/P	B	65	50	125	110	670	630	470	385	280	1084	1100	110	880	665	6xØ19 (M16)	258	B95D
50-315/75/P	B	65	50	125	110	670	630	470	385	280	1084	1100	110	880	665	6xØ19 (M16)	258	B95D
50-315/110/P	B	65	50	125	110	670	630	470	365	280	1198	1330	110	1110	645	6xØ19 (M16)	290,3	B95E
65-125/05/S	A	80	65	100	75	390	350	360	260	180	766	900	150	600	440	4xØ19 (M16)	83	B68B
65-125/07/X	A	80	65	100	75	390	350	360	260	180	734	900	150	600	440	4xØ19 (M16)	86	B68B
65-125/11/P	A	80	65	100	75	390	350	360	260	180	811	900	150	600	440	4xØ19 (M16)	92	B68C
65-125/15/P	A	80	65	100	75	390	350	360	260	180	811	900	150	600	440	4xØ19 (M16)	97	B68C
65-160/11A/P	A	80	65	100	75	450	400	360	260	200	811	1000	170	660	460	4xØ24 (M20)	113	B68C
65-160/11/P	A	80	65	100	75	450	400	360	260	200	811	1000	170	660	460	4xØ24 (M20)	113	B68C
65-160/15/P	A	80	65	100	75	450	400	360	260	200	811	1000	170	660	460	4xØ24 (M20)	118	B68C
65-160/22A/P	A	80	65	100	75	450	400	360	260	200	888	1000	170	660	460	4xØ24 (M20)	128	B80A
65-160/22/P	A	80	65	100	75	450	400	360	260	200	888	1000	170	660	460	4xØ24 (M20)	128	B80A
65-200/15/P	A	80	65	100	75	450	400	360	280	225	811	1000	170	660	505	4xØ24 (M20)	121	B68C
65-200/22A/P	A	80	65	100	75	490	440	360	280	225	888	1120	190	740	505	4xØ24 (M20)	137	B80A
65-200/22/P	A	80	65	100	75	490	440	360	280	225	888	1120	190	740	505	4xØ24 (M20)	137	B80A
65-200/30/P	A	80	65	100	75	490	440	360	280	225	906	1120	190	740	505	4xØ24 (M20)	142	B80A
65-200/40/P	A	80	65	100	75	490	440	360	280	225	906	1120	190	740	505	4xØ24 (M20)	161	B80A
65-250/30/P	A	80	65	100	90	490	440	470	310	250	1016	1120	190	740	560	4xØ24 (M20)	161	B95C
65-250/40/P	A	80	65	100	90	490	440	470	310	250	1016	1120	190	740	560	4xØ24 (M20)	180	B95C
65-250/55A/P	A	80	65	100	90	490	440	470	310	250	1058	1120	190	740	560	4xØ24 (M20)	189	B95D
65-250/55/P	A	80	65	100	90	490	440	470	310	250	1058	1120	190	740	560	4xØ24 (M20)	189	B95D
65-250/75/P	A	80	65	100	90	490	440	470	310	250	1058	1120	190	740	560	4xØ24 (M20)	193	B95D
65-315/55/P	B	80	65	125	110	670	630	470	385	280	1084	1100	110	880	665	6xØ19 (M16)	265,3	B95D
65-315/75/P	B	80	65	125	110	670	630	470	385	280	1084	1100	110	880	665	6xØ19 (M16)	265,3	B95D
65-315/110/P	B	80	65	125	110	670	630	470	365	280	1203	1330	110	1110	645	6xØ19 (M16)	297,5	B95E
65-315/150/P	B	80	65	125	110	670	630	470	365	280	1203	1330	110	1110	645	6xØ19 (M16)	342,4	B110E

NOTE: Pumps with flanges according to EN 1092-2 as standard.

Nscf40-65_4p50-en_d_td

Available ASME B16.5 version on request. For flanges dimensions see drawing.