

50 Hz



e-NSC Series

HORIZONTAL CENTRIFUGAL ELECTRIC PUMPS
EQUIPPED WITH **IE3** MOTORS

ErP 2009/125/EC



e-NSC 100-125-150 SERIES
HYDRAULIC PERFORMANCE RANGE AT 50 Hz, 4 POLES

PUMP TYPE	P _N kW	Ø Impeller (mm)				Q = DELIVERY													
		STD	B	●	η _p %	l/s	0	5.6	12.6	19.7	26.8	33.8	40.9	48.0	55.1	62.1	69.2	76.3	83.3
						m ³ /h	0	20	45	71	96	122	147	173	198	224	249	275	300
H = TOTAL HEAD METRES COLUMN OF WATER																			
100-160/22A	2.2	144	144	○	75.9	5.9		5.9	5.6	4.9	3.7								
100-160/22	2.2	156	156	○	77.4	6.9		6.9	6.6	6.0	4.8	3.5							
100-160/30	3	176	176	○	81.5	9.1		9.0	8.8	8.1	7.0	5.6	4.0						
100-160/40	4	190	190	●	83.6	10.8		10.6	10.4	9.8	8.9	7.6	6.0						
100-200/40	4.0	197	197	○	82.6	12.2		12.1	11.8	11.0	9.6	7.5	5.1						
100-200/55	5.5	213	213	○	83.8	14.8		14.6	14.5	13.8	12.6	10.7	8.4						
100-200/75	7.5	227	227	●	84.3	16.9		16.7	16.5	15.9	14.8	13.1	11.0	8.4					
100-250/55	5.5	213	213	○	80.6	14.1		14.1	13.8	13.1	11.9	10.1	8.0						
100-250/75	7.5	237	237	○	83.1	17.8		17.9	17.7	17.2	16.2	14.6	12.5	10.1					
100-250/110	11	259	259	●	84.1	21.9		21.9	21.7	21.1	20.0	18.4	16.3	13.8					
100-315/110	11	260	260	○	78.9	23.5	23.5	23.4	23.1	22.4	21.1	19.2	16.5	12.6					
100-315/150	15	284	284	○	79.5	28.0		28.0	27.8	27.2	26.0	24.4	22.4	19.5					
100-315/185	18.5	298	298	○	79.9	31.1		31.0	30.9	30.3	29.3	27.8	26.1	23.8	20.4				
100-315/220	22	312	312	○	80.6	34.3		34.2	34.1	33.7	32.8	31.4	29.6	27.6	25.0				
100-315/300	30	334	334	●	80.8	40.2		40.1	40.1	39.7	38.8	37.6	36.0	34.0	31.5	28.2			
100-400/300	30	375	375	○	76.8	47.4		46.5	45.8	44.9	43.7	42.1	40.0	37.4	34.3	30.6			
100-400/370	37	397	397	○	77.1	54.4		53.3	52.5	51.6	50.4	48.9	47.1	44.8	42.0	38.6	34.7		
100-400/450	45	420	420	●	76.9	61.3		60.0	59.4	58.6	57.3	55.7	53.8	51.6	49.0	45.8	42.0	37.3	

PUMP TYPE	P _N kW	Ø Impeller (mm)				Q = DELIVERY													
		STD	B	●	η _p %	l/s	0	11.9	21.4	30.9	40.5	50.0	59.5	69.0	78.6	88.1	97.6	107.1	116.7
						m ³ /h	0	43	77	111	146	180	214	249	283	317	351	386	420
H = TOTAL HEAD METRES COLUMN OF WATER																			
125-200/55	5.5	179	179	○	80.9	8.6		8.4	8.4	8.3	8.0	7.2	6.0						
125-200/75	7.5	204	204	○	83.5	11.9		11.8	11.8	11.6	11.2	10.3	9.0	7.5					
125-200/110	11	225	225	●	85.4	15.0		14.9	14.9	14.8	14.4	13.7	12.6	11.1	9.3				
125-250/75	7.5	210	210	○	84.5	13.6	13.5	13.4	13.3	12.9	12.1	10.6	8.6	6.3					
125-250/110	11	235	235	○	86.3	17.5		17.4	17.4	17.2	16.6	15.3	13.5	11.3	9.2				
125-250/150	15	259	259	●	88.3	22.0		21.7	21.7	21.5	21.0	20.0	18.5	16.5	14.1	11.6			
125-315/185	18.5	277	277	○	83.7	25.6		25.7	25.6	25.3	24.4	22.8	20.1	16.4	11.9	7.3			
125-315/220	22	290	290	○	84.3	28.3		28.6	28.5	28.2	27.5	26.1	23.8	20.7	16.6				
125-315/300	30	315	315	○	85.4	34.8		35.1	35.0	34.8	34.1	33.0	31.4	29.1	26.0	22.1			
125-315/370	37	334	334	●	86.4	39.6		39.8	39.9	39.7	39.2	38.2	36.8	34.8	32.1	28.7	24.6		
125-400/370	37	353	353	○	78.0	43.4		43.9	43.8	43.2	41.9	39.9	37.0	33.0	28.0				
125-400/450	45	374	374	○	78.8	48.7		49.4	49.6	49.3	48.3	46.4	43.7	40.0	35.4	30.0			
125-400/550	55	394	394	○	79.1	54.4		55.6	55.8	55.5	54.6	53.0	50.7	47.6	43.6	38.7			
125-400/750	75	422	422	●	79.9	63.4		64.8	64.7	64.2	63.3	61.8	59.8	57.1	53.8	49.8	45.0	39.3	

PUMP TYPE	P _N kW	Ø Impeller (mm)				Q = DELIVERY													
		STD	B	●	η _p %	l/s	0	16.7	33.8	51.0	68.2	85.4	102.5	119.7	136.9	154.0	171.2	188.4	205.6
						m ³ /h	0	60	122	184	245	307	369	431	493	555	616	678	740
H = TOTAL HEAD METRES COLUMN OF WATER																			
150-200/110A	11	200	200	○	78.8	11.8		11.3	10.5	9.4	8.3	7.0	5.4						
150-200/110	11	217	217	○	80.7	14.0		13.4	12.5	11.4	10.1	8.7	7.0	4.9					
150-200/150A	15	227	227	○	82.0	15.2		14.5	13.8	12.9	11.7	10.2	8.4	6.4					
150-200/150	15	237	237	●	83.9	16.3		15.6	15.1	14.4	13.4	12.0	10.3	8.2					
150-250/150	15	238	238	○	80.3	17.2	17.0	16.7	16.1	15.1	13.7	11.6	9.1						
150-250/185	18.5	253	253	○	82.7	19.8		19.1	18.7	17.9	16.6	14.8	12.4	9.5					
150-250/220	22	265	265	○	84.6	22.1		21.4	21.0	20.4	19.3	17.6	15.4	12.6					
150-250/300	30	282	282	●	86.2	26.4		25.3	24.7	23.9	22.9	21.5	19.6	17.3	14.4				
150-315/300	30	291	291	○	84.2	27.7		27.7	27.6	27.0	25.7	23.5	20.4	16.5					
150-315/370	37	310	310	○	85.1	31.9		31.8	31.6	31.1	30.0	28.1	25.3	21.5	17.1				
150-315/450	45	330	330	●	86.3	36.6		36.2	36.1	35.7	34.7	32.9	30.4	27.2	23.2				
150-400/450	45	327	327	○	81.8	36.7		36.9	36.6	35.6	34.0	31.7	28.6	24.6					
150-400/550	55	346	346	○	84.4	41.2		41.6	41.5	40.9	39.5	37.5	34.6	30.9	26.3				
150-400/750	75	377	377	○	84.9	50.3		50.8	50.9	50.4	49.1	47.0	44.4	41.3	37.7	33.3			
150-400/900	90	398	398	○	85.3	56.5		56.9	57.0	56.5	55.5	53.7	51.4	48.5	45.1	41.0			
150-400/1100	110	423	423	●	85.5	63.9		64.4	64.3	63.9	63.0	61.5	59.4	56.6	53.2	49.1	44.4		
150-500/900	90	420	420	○	75.1	60.9		61.6	61.8	61.1	59.0	55.2	49.6	42.6	34.5				
150-500/1100	110	443	443	○	75.4	68.5		68.9	69.3	69.0	67.5	64.4	59.5	52.7	44.6	36.1			
150-500/1320	132	467	467	○	76.5	76.9		77.6	78.1	78.0	76.9	74.3	70.1	64.0	56.3	47.3			
150-500/1600	160	495	495	○	77.9	87.0		87.9	88.4	88.5	87.8	86.0	82.7	77.6	70.7	62.1	52.6		
150-500/2000	200	516	516	●	78.6	95.1		95.9	96.5	96.7	96.1	94.4	91.4	86.7	80.4	72.6	63.5	53.7	

Hydraulic performances in compliance with ISO 9906:2012 - Grade 3B (ex ISO 9906:1999 - Annex A)

Nsc-100-150_4p50-en_c_th

(1) STD = Cast iron/Stainless steel - B = Bronze (2) ● = Full impeller diameter - ○ = Trimmed impeller diameter (3) Hydraulic efficiency of pump.

e-NSC SERIES
OPERATING CHARACTERISTICS AT 50 Hz, 4 POLES

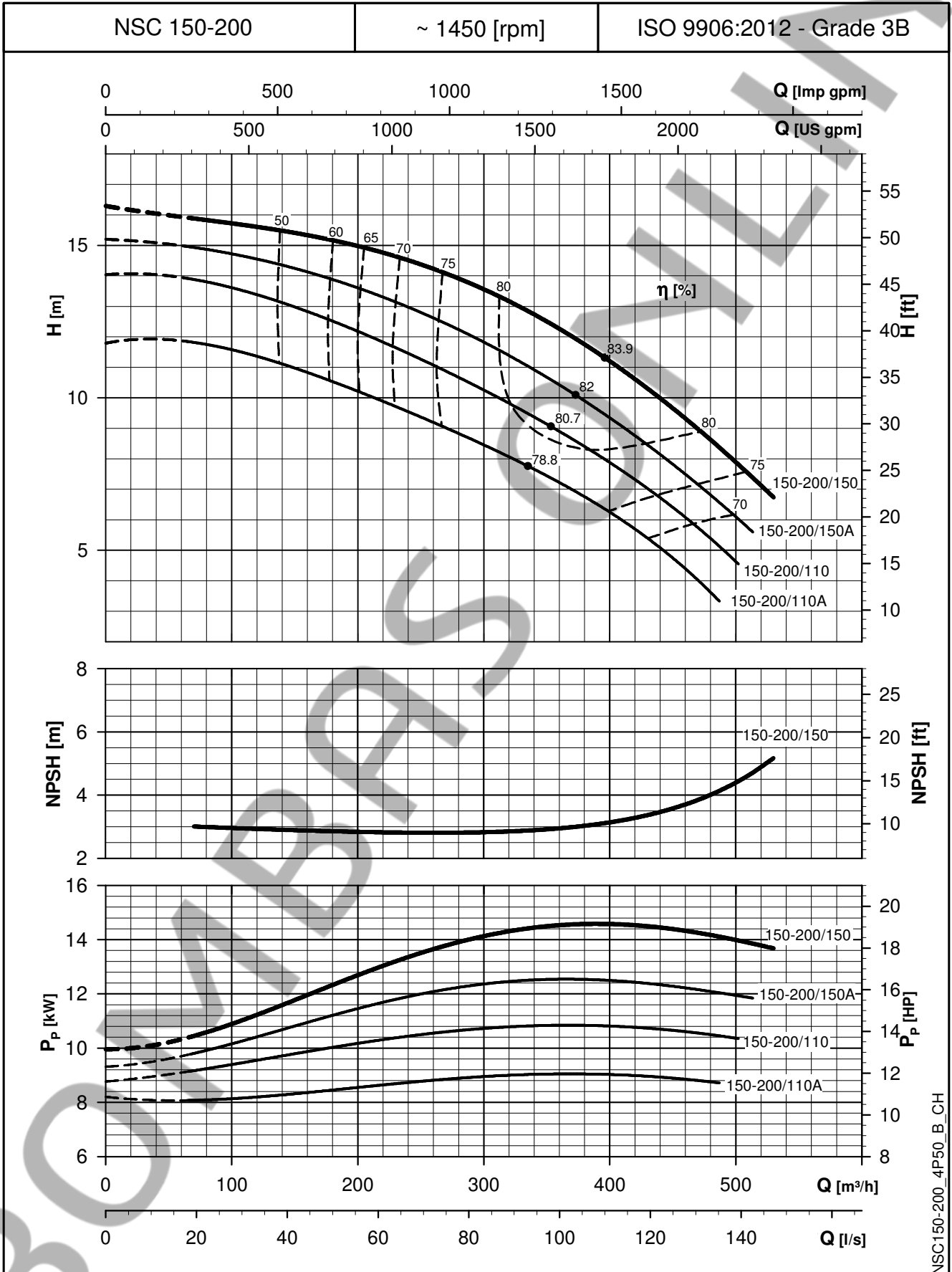

NSC150-200_4P50_B_CH

The NPSH values are laboratory values; for practical use we suggest increasing these values by 0,5 m.
These performances are valid for liquids with density ρ = 1,0 Kg/dm³ and kinematic viscosity ν = 1 mm²/sec.

e-NSC SERIES
OPERATING CHARACTERISTICS AT 50 Hz, 4 POLES

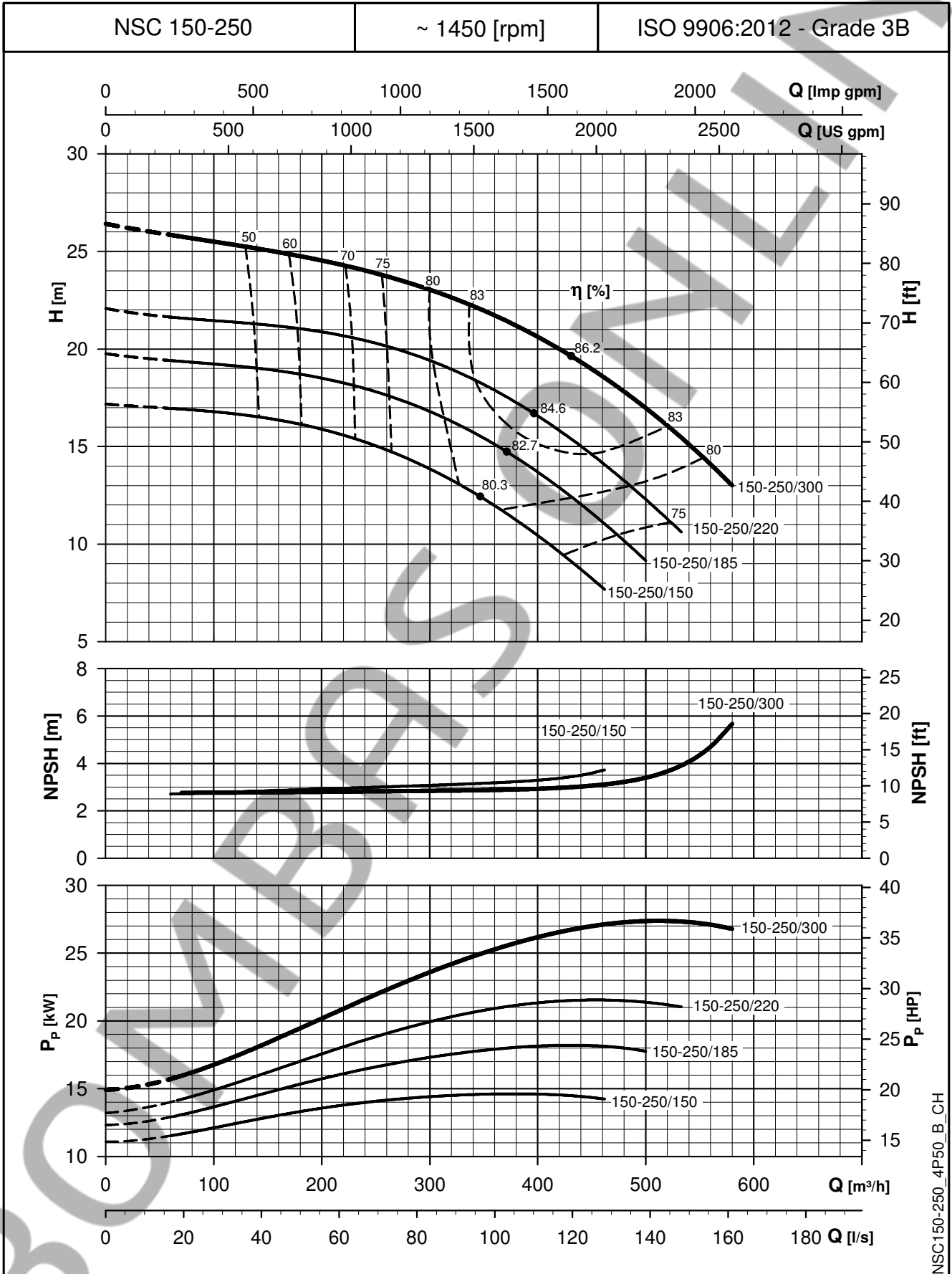

NSC150-250_4P50_B_CH

The NPSH values are laboratory values; for practical use we suggest increasing these values by 0,5 m.
These performances are valid for liquids with density $\rho = 1,0 \text{ Kg/dm}^3$ and kinematic viscosity $\nu = 1 \text{ mm}^2/\text{sec}$.

e-NSC SERIES
OPERATING CHARACTERISTICS AT 50 Hz, 4 POLES

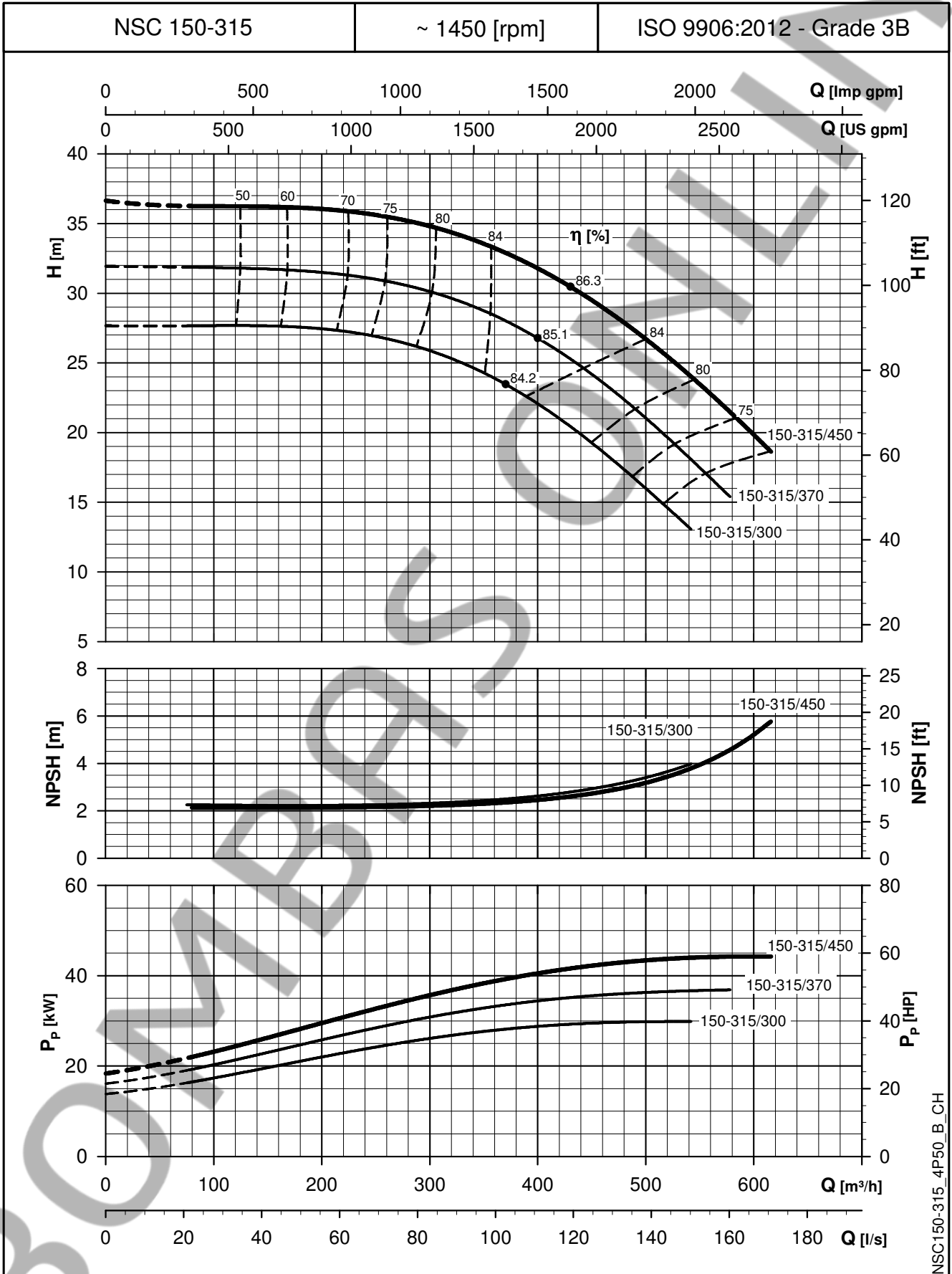

NSC150-315_4P50_B_CH

The NPSH values are laboratory values; for practical use we suggest increasing these values by 0,5 m.
These performances are valid for liquids with density $\rho = 1,0 \text{ Kg/dm}^3$ and kinematic viscosity $\nu = 1 \text{ mm}^2/\text{sec}$.

e-NSC SERIES
OPERATING CHARACTERISTICS AT 50 Hz, 4 POLES

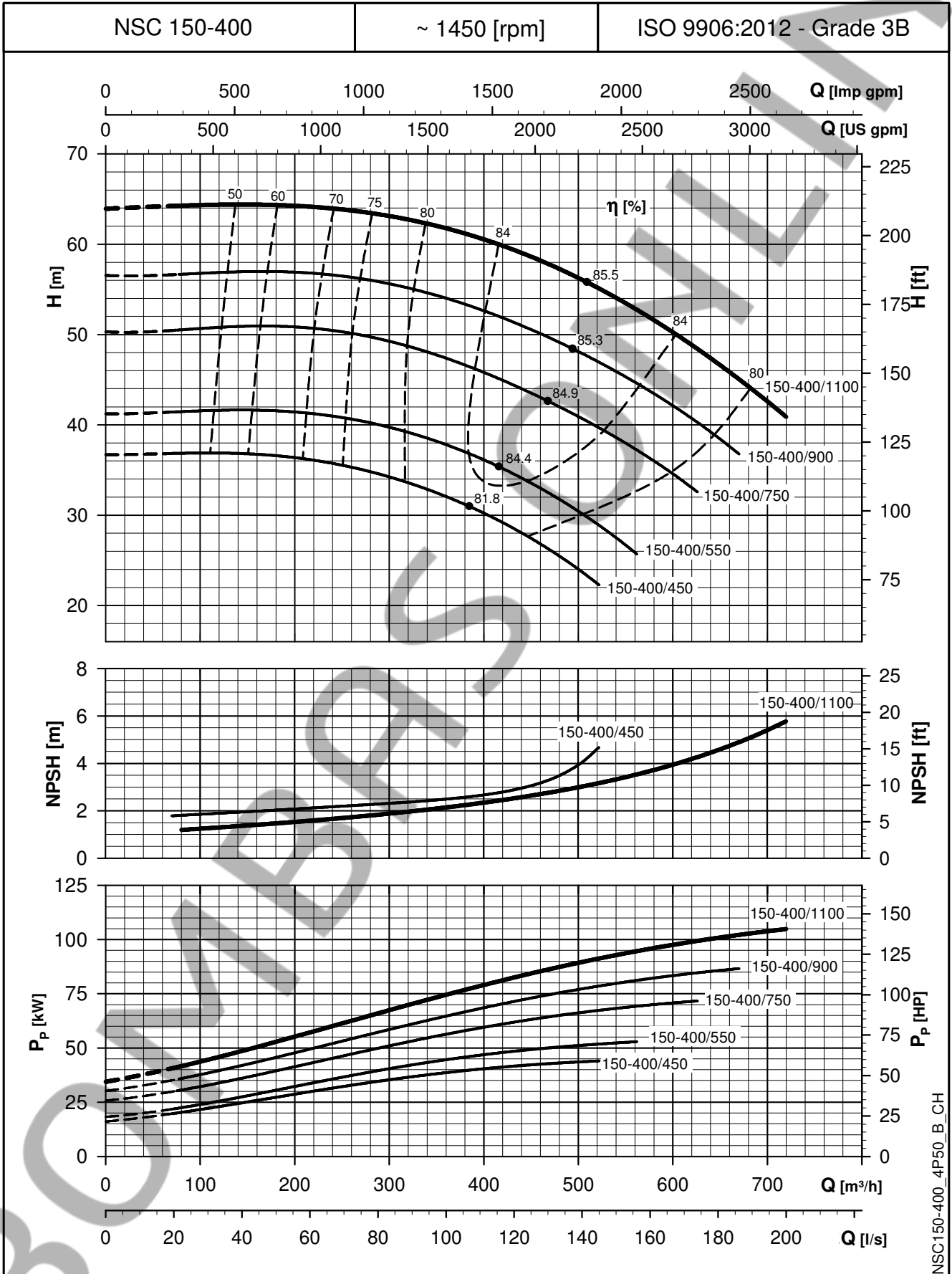

NSC150-400_4P50_B_CH

The NPSH values are laboratory values; for practical use we suggest increasing these values by 0,5 m.
These performances are valid for liquids with density ρ = 1,0 Kg/dm³ and kinematic viscosity ν = 1 mm²/sec.

e-NSC SERIES
OPERATING CHARACTERISTICS AT 50 Hz, 4 POLES

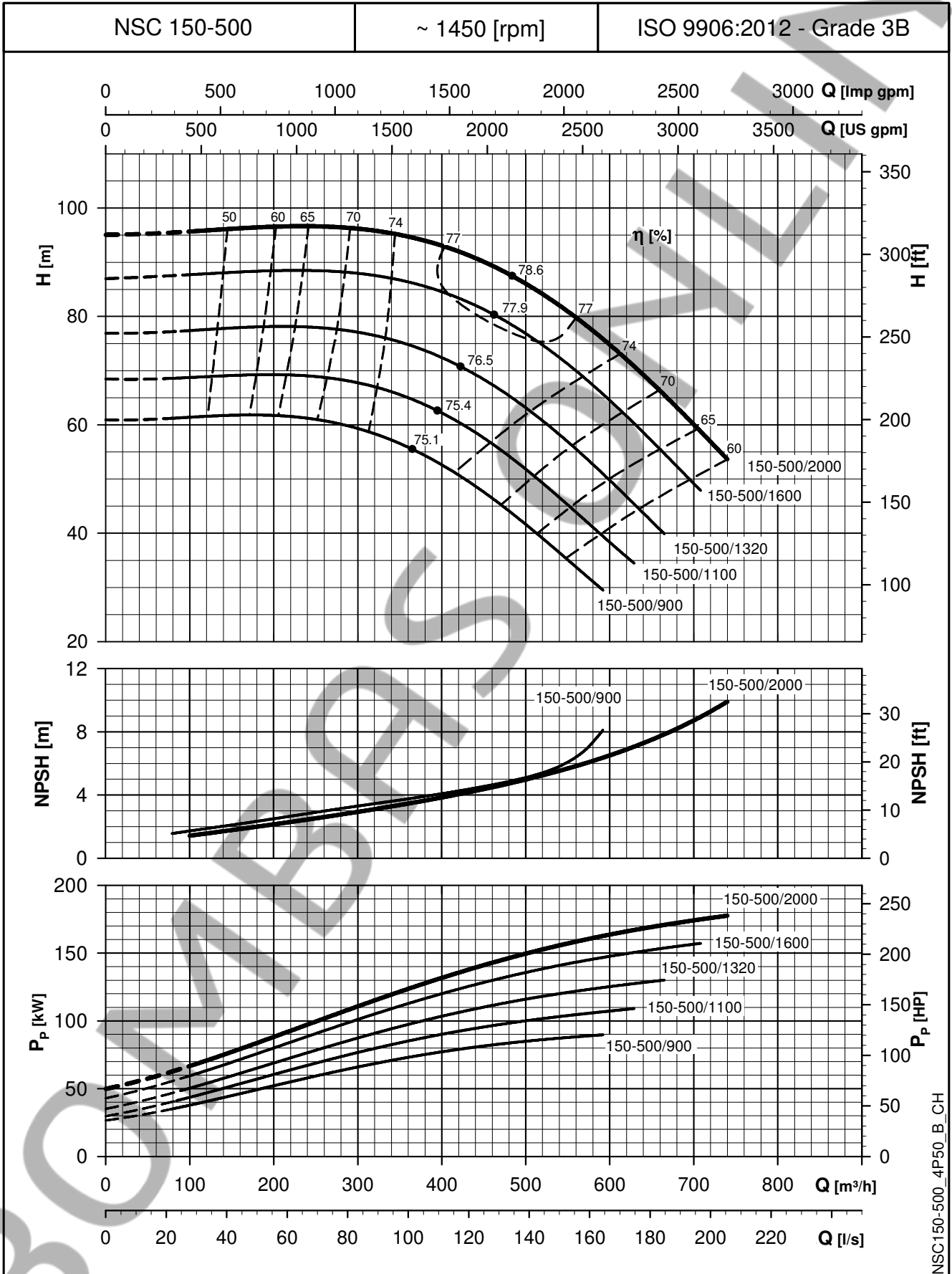

NSC150-500_4P50_B_CH

The NPSH values are laboratory values; for practical use we suggest increasing these values by 0,5 m.
These performances are valid for liquids with density $\rho = 1,0 \text{ Kg/dm}^3$ and kinematic viscosity $\nu = 1 \text{ mm}^2/\text{sec}$.

**NSCF 150 SERIES (MOUNTED ON BASE)
DIMENSIONS AND WEIGHTS AT 50 Hz, 4 POLES**

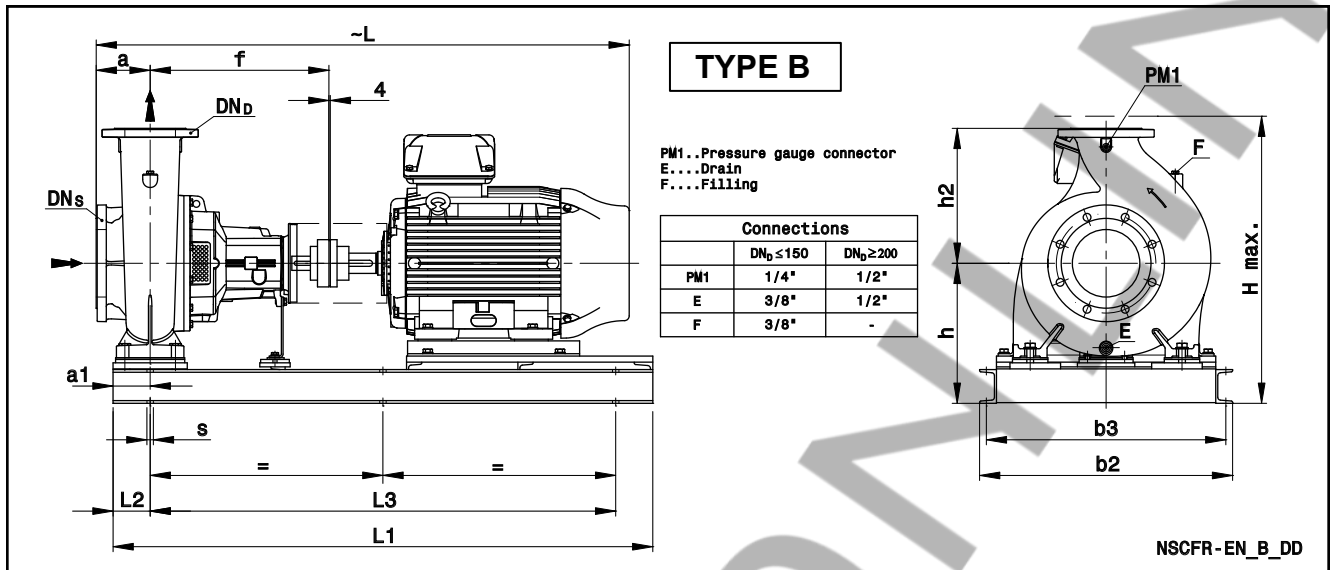

PUMP TYPE NSCF..4	TYPE	DIMENSIONS (mm)														H max	s FOR SCREWS	WEIGHT (kg) G	COUPLING TYPE
		DN _S	DN _D	a	a1	b2	b3	f	h	h2	L	L1	L2	L3					
150-200/110A/P	B	200	150	160	110	670	630	470	385	400	1238	1330	110	1110	785	6xØ19 (M16)	357	B95E	
150-200/110/P	B	200	150	160	110	670	630	470	385	400	1238	1330	110	1110	785	6xØ19 (M16)	357	B95E	
150-200/150A/P	B	200	150	160	110	670	630	470	385	400	1238	1330	110	1110	785	6xØ19 (M16)	402	B110E	
150-200/150/P	B	200	150	160	110	670	630	470	385	400	1238	1330	110	1110	785	6xØ19 (M16)	402	B110E	
150-250/150/P	B	200	150	160	110	670	630	530	385	400	1298	1430	110	1210	785	6xØ19 (M16)	413	B110C	
150-250/185/W	B	200	150	160	110	670	630	530	400	400	1358	1430	110	1210	800	6xØ19 (M16)	472	B110D	
150-250/220/W	B	200	150	160	110	670	630	530	400	400	1396	1430	110	1210	800	6xØ19 (M16)	490	B110D	
150-250/300/W	B	200	150	160	110	670	630	530	420	400	1461	1430	110	1210	820	6xØ19 (M16)	545	B125C	
150-315/300/W	B	200	150	160	110	670	630	530	420	400	1461	1430	110	1210	820	6xØ19 (M16)	551	B125C	
150-315/370/W	B	200	150	160	110	750	710	530	415	400	1580	1600	110	1380	815	6xØ19 (M16)	737	B140B	
150-315/450/W	B	200	150	160	110	750	710	530	415	400	1580	1600	110	1380	815	6xØ19 (M16)	765	B140B	
150-400/450/W	B	200	150	160	110	750	710	530	440	450	1580	1600	110	1380	890	6xØ19 (M16)	809	B140B	
150-400/550/W	B	200	150	160	110	750	710	530	440	450	1659	1600	110	1380	890	6xØ19 (M16)	893	B160B	
150-400/750/W	B	200	150	160	110	750	710	530	440	450	1765	1600	110	1380	912	6xØ19 (M16)	1103	B180B	
150-400/900/W	B	200	150	160	110	750	710	530	440	450	1765	1600	110	1380	912	6xØ19 (M16)	1151	B180B	
150-400/1100/W	B	200	150	160	110	750	710	530	440	450	1765	1600	110	1380	912	6xØ19 (M16)	1258	B180B	
150-500/900/W	B	200	150	180	165	860	810	770	565	500	2025	1750	165	1420	1065	6xØ26 (M20)	1384	B180C	
150-500/1100/W	B	200	150	180	165	860	810	770	585	500	2228	2000	165	1670	1115	6xØ26 (M20)	1678	B200A	
150-500/1320/W	B	200	150	180	165	860	810	770	585	500	2228	2000	165	1670	1115	6xØ26 (M20)	1763	B200A	
150-500/1600/W	B	200	150	180	165	860	810	770	585	500	2228	2000	165	1670	1115	6xØ26 (M20)	1820	B200A	
150-500/2000/W	B	200	150	180	165	860	810	770	585	500	2337	2000	165	1670	1160	6xØ26 (M20)	2005	B225A	

NOTE: Pumps with flanges according to EN 1092-2 as standard.

Nscf150_4p50-en_d_td

Available ASME B16.5 version on request. For flanges dimensions see drawing.

NSCF 200, 250, 300 SERIES (MOUNTED ON BASE) DIMENSIONS AND WEIGHTS AT 50 Hz, 4 POLES

PUMP TYPE NSCF..4	TYPE	DIMENSIONS (mm)															WEIGHT (kg) G	COUPLING TYPE
		DNS	DND	a	a1	b2	b3	f	h	h2	L	L1	L2	L3	H max	s FOR SCREWS		
200-250/185/W	B	250	200	180	110	670	630	530	460	475	1378	1450	110	1230	935	6xØ19 (M16)	527	B110D
200-250/220/W	B	250	200	180	110	670	630	530	460	475	1416	1450	110	1230	935	6xØ19 (M16)	545	B110D
200-250/300A/W	B	250	200	180	110	670	630	530	460	475	1481	1450	110	1230	935	6xØ19 (M16)	588	B125C
200-250/300/W	B	250	200	180	110	670	630	530	460	475	1481	1450	110	1230	935	6xØ19 (M16)	588	B125C
200-315/300/W	B	250	200	180	110	670	630	530	460	450	1481	1450	110	1230	910	6xØ19 (M16)	592	B125C
200-315/370/W	B	250	200	180	110	750	710	530	480	450	1600	1660	110	1440	930	6xØ19 (M16)	791	B140B
200-315/450/W	B	250	200	180	110	750	710	530	480	450	1600	1660	110	1440	930	6xØ19 (M16)	819	B140B
200-315/550/W	B	250	200	180	110	750	710	530	480	450	1679	1660	110	1440	930	6xØ19 (M16)	904	B160B
200-315/750/W	B	250	200	180	110	750	710	530	480	450	1785	1660	110	1440	952	6xØ19 (M16)	1113	B180B
200-400/750A/W	B	250	200	180	165	860	810	770	565	500	2025	1750	165	1420	1065	6xØ26 (M20)	1291	B180C
200-400/750/W	B	250	200	180	165	860	810	770	565	500	2025	1750	165	1420	1065	6xØ26 (M20)	1291	B180C
200-400/900/W	B	250	200	180	165	860	810	770	565	500	2025	1750	165	1420	1065	6xØ26 (M20)	1339	B180C
200-400/1100/W	B	250	200	180	165	860	810	770	585	500	2228	2000	165	1670	1115	6xØ26 (M20)	1633	B200A
200-400/1320/W	B	250	200	180	165	860	810	770	585	500	2228	2000	165	1670	1115	6xØ26 (M20)	1718	B200A
200-500/1320/W	B	250	200	200	165	860	810	770	635	560	2248	2000	165	1670	1195	6xØ26 (M20)	1778	B200A
200-500/1600/W	B	250	200	200	165	860	810	770	635	560	2248	2000	165	1670	1195	6xØ26 (M20)	1835	B200A
200-500/2000/W	B	250	200	200	165	860	810	770	635	560	2357	2000	165	1670	1210	6xØ26 (M20)	2019	B225A
200-500/2500/W	B	250	200	200	165	860	810	770	635	560	2357	2000	165	1670	1210	6xØ26 (M20)	2214	B225A
200-500/3150/W	B	250	200	200	165	1000	930	770	675	560	2456	2200	165	1870	1300	6xØ29 (M24)	2553	B250A
250-315/370/W	B	300	250	250	165	850	810	530	525	500	1670	1700	165	1370	1025	6xØ19 (M16)	905	B140B
250-315/450/W	B	300	250	250	165	850	810	530	525	500	1670	1700	165	1370	1025	6xØ19 (M16)	933	B140B
250-315/550/W	B	300	250	250	165	850	810	530	525	500	1749	1700	165	1370	1025	6xØ19 (M16)	1017	B160B
250-315/750/W	B	300	250	250	165	850	810	530	525	500	1855	1700	165	1370	1025	6xØ19 (M16)	1227	B180B
250-400/750/W	B	300	250	200	165	860	810	770	565	560	2045	1750	165	1420	1125	6xØ26 (M20)	1328	B180C
250-400/900/W	B	300	250	200	165	860	810	770	565	560	2045	1750	165	1420	1125	6xØ26 (M20)	1376	B180C
250-400/1100/W	B	300	250	200	165	860	810	770	585	560	2248	2000	165	1670	1145	6xØ26 (M20)	1670	B200A
250-400/1320/W	B	300	250	200	165	860	810	770	585	560	2248	2000	165	1670	1145	6xØ26 (M20)	1755	B200A
250-400/1600/W	B	300	250	200	165	860	810	770	585	560	2248	2000	165	1670	1145	6xØ26 (M20)	1812	B200A
250-400/2000/W	B	300	250	200	165	860	810	770	585	560	2357	2000	165	1670	1160	6xØ26 (M20)	1997	B225A
250-500/1600/W	B	300	250	200	165	860	810	770	635	670	2248	2000	165	1670	1305	6xØ26 (M20)	1886	B200A
250-500/2000/W	B	300	250	200	165	860	810	770	635	670	2357	2000	165	1670	1305	6xØ26 (M20)	2070	B225A
250-500/2500/W	B	300	250	200	165	860	810	770	635	670	2357	2000	165	1670	1305	6xØ26 (M20)	2265	B225A
250-500/3150/W	B	300	250	200	165	1000	930	770	675	670	2456	2200	165	1870	1345	6xØ29 (M24)	2604	B250A
250-500/3550/W	B	300	250	200	165	1000	930	770	675	670	2456	2200	165	1870	1345	6xØ29 (M24)	2710	B250A
300-350/750A/W	B	350	300	250	200	960	910	800	620	600	2125	1850	200	1450	1220	6xØ26 (M20)	1514	B180C
300-350/750/W	B	350	300	250	200	960	910	800	620	600	2125	1850	200	1450	1220	6xØ26 (M20)	1514	B180C
300-350/900/W	B	350	300	250	200	960	910	800	620	600	2125	1850	200	1450	1220	6xØ26 (M20)	1562	B180C
300-350/1100/W	B	350	300	250	200	960	910	800	640	600	2328	2100	200	1700	1240	6xØ26 (M20)	1871	B200A
300-400/1100/W	B	350	300	250	200	960	910	800	640	600	2328	2100	200	1700	1240	6xØ26 (M20)	1875	B200A
300-400/1320/W	B	350	300	250	200	960	910	800	640	600	2328	2100	200	1700	1240	6xØ26 (M20)	1960	B200A
300-400/1600/W	B	350	300	250	200	960	910	800	640	600	2328	2100	200	1700	1240	6xØ26 (M20)	2017	B200A
300-400/2000/W	B	350	300	250	200	960	910	800	640	600	2437	2100	200	1700	1240	6xØ26 (M20)	2201	B225A
300-400/2500/W	B	350	300	250	200	960	910	800	640	600	2437	2100	200	1700	1240	6xØ26 (M20)	2396	B225A
300-450/1600/W	B	350	300	250	200	960	910	800	665	630	2328	2100	200	1700	1295	6xØ26 (M20)	2058	B200A
300-450/2000/W	B	350	300	250	200	960	910	800	665	630	2437	2100	200	1700	1295	6xØ26 (M20)	2243	B225A
300-450/2500/W	B	350	300	250	200	960	910	800	665	630	2437	2100	200	1700	1295	6xØ26 (M20)	2438	B225A
300-450/3150/W	B	350	300	250	200	1000	930	800	705	630	2536	2250	200	1850	1335	6xØ29 (M24)	2754	B250A

NOTE: Pumps with flanges according to EN 1092-2 as standard.

Nscf200-300_4p50-en_d_td

Available ASME B16.5 version on request. For flanges dimensions see drawing.