

50 Hz



## e-NSC Series

HORIZONTAL CENTRIFUGAL ELECTRIC PUMPS  
EQUIPPED WITH **IE3** MOTORS

ErP 2009/125/EC

### e-NSC 32, 40, 50 SERIES HYDRAULIC PERFORMANCE TABLE AT 50 Hz, 2 POLES

PUMP TYPE	P <sub>N</sub> kW	Ø Impeller (mm)				Q = DELIVERY													
		STD (1)	B (2)	● (3)	η <sub>p</sub> %	vs 0	1,8	2,6	3,5	4,4	5,3	6,1	7,0	7,9	8,8	9,6	10,5	11,4	
						m <sup>3</sup> /h 0	6	9	13	16	19	22	25	28	32	35	38	41	
H = TOTAL HEAD METRES COLUMN OF WATER																			
32-125/11*	1,1	113	-	○	60,7	14,2	14,4	14,2	13,7	12,9	11,8	10,2	8,2						
32-125/15*	1,5	123	-	○	65,9	17,9		18,0	17,5	16,7	15,7	14,3	12,6	10,5					
32-125/22*	2,2	133	-	○	70,2	22,7		23,0	22,8	22,3	21,7	20,7	19,5	17,9	16,0	13,6			
32-125/30	3	145	-	●	70,4	27,7			28,4	28,1	27,5	26,6	25,5	24,0	22,3	20,2	17,8	15,1	
32-160/22*	2,2	137	-	○	62,5	24,2		23,9	23,6	23,0	22,1	20,7	18,7						
32-160/30	3	150	-	○	65,7	29,3		29,5	29,2	28,7	27,9	26,6	25,0	22,9	20,2				
32-160/40	4	160,5	-	○	66,1	34,4		35,0	34,9	34,6	34,0	32,9	31,4	29,5	27,0	24,0			
32-160/55	5,5	171	-	●	67,5	40,4			40,9	40,7	40,2	39,3	38,1	36,3	34,1	31,4	28,1		
32-200/30	3	158	-	○	57,2	33,1		32,6	31,9	30,7	28,8	26,1							
32-200/40	4	171	-	○	61,1	40,2		39,8	39,4	38,6	37,3	35,4	32,6						
32-200/55	5,5	186	-	○	61,7	48,9		48,4	48,0	47,2	46,1	44,4	42,0	38,8					
32-200/75	7,5	205	-	●	63,4	62,4			61,9	61,1	59,6	57,6	55,2	52,8	50,0				
NSC2 32-250/55	5,5	174	-	○	49,9	70,3		64,7	61,3	56,5	50,6	44,0							
NSC2 32-250/75	7,5	190,5	-	●	50,4	88,3		82,0	79,1	74,6	68,6	61,6	54,2						
32-250/75	7,5	214	-	○	45,5	58,7			57,5	56,0	53,7	50,6	46,5	41,0					
32-250/92	9,2	226,5	-	○	47,5	66,8			65,8	64,6	62,7	60,3	57,2	52,8					
32-250/110A	11	226,5	-	○	47,5	66,8			65,8	64,6	62,7	60,3	57,2	52,8					
32-250/110	11	239	-	○	48,3	76,0				73,7	71,7	69,2	66,1	62,2	57,0				
32-250/150	15	259	-	●	50,5	92,5				91,0	90,4	89,3	87,4	84,3	79,5	72,3	62,2		

PUMP TYPE	P <sub>N</sub> kW	Ø Impeller (mm)				Q = DELIVERY													
		STD (1)	B (2)	○ (3)	η <sub>p</sub> %	vs 0	2,7	4,1	5,5	6,9	8,4	9,8	11,2	12,6	14,1	15,5	16,9	18,3	
						m <sup>3</sup> /h 0	10	15	20	25	30	35	40	45	51	56	61	66	
H = TOTAL HEAD METRES COLUMN OF WATER																			
40-125/15*	1,5	105	-	○	69,3	14,5	14,7	14,5	13,9	13,1	11,9	10,5							
40-125/22*	2,2	118	-	○	73,1	19,4		18,8	18,2	17,4	16,4	15,0	13,3	11,1					
40-125/30	3	130	-	○	78,1	23,2		22,9	22,6	22,0	21,2	20,0	18,6	16,9	15,0				
40-125/40	4	135	-	●	81,1	26,7			26,5	26,2	25,7	25,0	24,0	22,8	21,3	19,5			
40-160/30	3	127	-	○	69,2	21,8		22,8	22,5	21,8	20,7	19,3	17,4						
40-160/40	4	139	-	○	71,6	26,4		27,8	27,7	27,2	26,4	25,2	23,6	21,6					
40-160/55	5,5	154	-	○	75,0	33,3		34,7	34,7	34,4	33,8	32,8	31,5	29,9	28,0	25,7			
40-160/75	7,5	165	-	●	75,6	40,8			41,3	41,2	40,9	40,2	39,2	37,9	36,2	34,3	32,0		
40-200/55	5,5	165	-	○	62,4	36,2		36,6	36,4	35,7	34,4	32,4	29,5						
40-200/75	7,5	179	-	○	64,0	44,2		45,0	44,8	44,2	43,3	41,7	39,4	36,1	31,6				
40-200/92	9,2	189	-	○	67,3	49,8			50,9	50,5	50,0	49,0	47,6	45,2	41,6	36,3			
40-200/110A	11	189	-	○	67,3	49,8			50,9	50,5	50,0	49,0	47,6	45,2	41,6	36,3			
40-200/110	11	199	-	●	67,6	56,1			57,1	56,8	56,3	55,4	53,9	51,8	48,7	44,5	38,8		
40-250/92	9,2	199	-	○	58,8	54,9			54,8	54,1	52,7	50,5	47,2						
40-250/110A	11	199	-	○	58,8	54,9			54,8	54,1	52,7	50,5	47,2						
40-250/110	11	210	-	○	59,3	60,5			59,5	58,9	57,7	55,9	53,1	49,0					
40-250/150	15	228	-	○	61,0	73,9				72,7	71,9	70,6	68,7	65,9	61,9				
40-250/185	18,5	243	-	○	65,2	86,5				85,2	84,5	83,6	82,2	80,1	77,1	72,9			
40-250/220	22	257,5	-	●	66,8	99,8				98,1	97,4	96,6	95,5	93,8	91,3	87,9	83,1	76,6	

PUMP TYPE	P <sub>N</sub> kW	Ø Impeller (mm)				Q = DELIVERY													
		STD (1)	B (2)	○ (3)	η <sub>p</sub> %	vs 0	4,6	7,5	10,4	13,4	16,3	19,2	22,1	25,0	27,9	30,8	33,8	36,7	
						m <sup>3</sup> /h 0	17	27	38	48	59	69	80	90	101	111	122	132	
H = TOTAL HEAD METRES COLUMN OF WATER																			
50-125/30	3	118	-	○	66,1	17,1		16,2	15,2	13,7	11,7	9,3	6,5						
50-125/40	4	130	-	○	70,6	21,3		20,4	19,5	18,1	16,3	14,0	11,2	8,2					
50-125/55	5,5	144	-	○	73,2	26,9		25,6	24,9	23,8	22,2	20,1	17,6	14,7	11,5				
50-125/75	7,5	148	-	●	75,2	30,9		29,2	28,4	27,3	25,9	24,1	21,9	19,3	16,2	12,8			
50-160/55	5,5	144	-	○	71,9	27,1		26,2	25,3	23,8	21,7	18,9	15,7						
50-160/75	7,5	159	-	○	72,2	33,8		32,7	31,8	30,2	28,0	25,2	21,9	18,1					
50-160/92	9,2	170	-	○	72,6	38,8		38,0	37,3	36,0	34,1	31,6	28,5	24,9	20,7				
50-160/110A	11	170	-	○	72,6	38,8		38,0	37,3	36,0	34,1	31,6	28,5	24,9	20,7				
50-160/110	11	176	-	●	74,9	43,5		42,3	41,5	40,3	38,7	36,6	34,0	30,8	27,1	22,7			
50-200/92	9,2	168	-	○	70,7	36,5		37,5	37,5	36,8	35,1	32,4	28,5						
50-200/110A	11	168	-	○	70,7	36,5		37,5	37,5	36,8	35,1	32,4	28,5						
50-200/110	11	179	-	○	72,2	42,5		43,5	43,5	42,6	40,6	37,3	32,9						
50-200/150	15	197	-	○	74,4	53,5		54,3	54,3	53,6	51,9	49,0	44,9	39,8					
50-200/185	18,5	209	-	●	77,4	62,7		63,0	63,0	62,6	61,4	59,5	56,6	52,7	48,0				
50-250/150	15	208	-	○	65,4	57,9		57,7	57,2	55,6	52,8	48,3	42,1						
50-250/185	18,5	220	-	○	69,8	67,1		66,9	66,4	65,0	62,5	58,5	52,9	45,4					
50-250/220	22	232	-	○	70,3	75,1		74,9	74,4	73,2	71,0	67,6	62,5	55,7	46,7				
50-250/300	30	256	-	●	71,5	93,2		93,5	93,3	92,5	90,8	87,9	83,6	77,7	70,1	60,6			
50-315/370	37	264	-	○	61,2	101,7	100,8	100,2	98,3	95,3	92,0	88,9	86,1	82,2					
50-315/450	45	278	-	○	62,1	112,7		112,4	111,2	108,8	105,6	102,2	98,8	95,3	90,2				
50-315/550	55	298	-	○	63,2	131,0		128,6	127,8	126,6	124,6	121,7	117,8	113,6	109,3	104,3			
50-315/750	75	322	-	●	64,2	154,0		151,9	151,6	151,0	149,7	147,3	143,8	139,4	134,9	130,3	125,0	117,1	

Hydraulic performances in compliance with ISO 9906:2012 - Grade 3B (ex ISO 9906:1999 - Annex A)

Nsc-32-40-50\_2p50-en\_f\_th

(1) STD = Cast iron/Stainless steel - B = Bronze (2) ● = Full impeller diameter - ○ = Trimmed impeller diameter (3) Hydraulic efficiency of pump.

\*Available also in single-phase version.

**e-NSC SERIES**  
**OPERATING CHARACTERISTICS AT 50 Hz, 2 POLES**

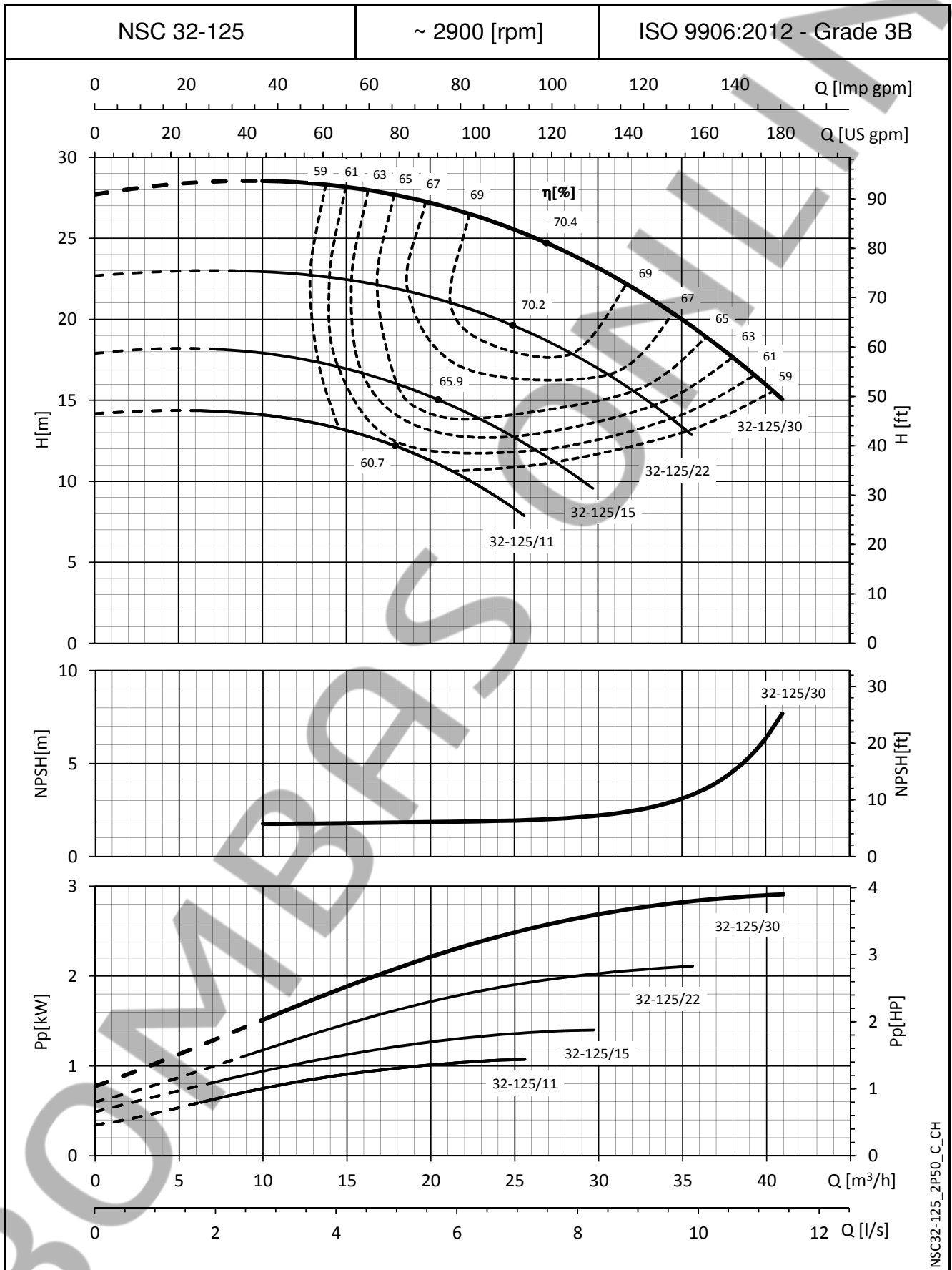

NSC32-125\_2P50\_C\_CH

The NPSH values are laboratory values; for practical use we suggest increasing these values by 0,5 m.  
These performances are valid for liquids with density  $\rho = 1,0 \text{ Kg/dm}^3$  and kinematic viscosity  $\nu = 1 \text{ mm}^2/\text{sec}$ .

**e-NSC SERIES**  
**OPERATING CHARACTERISTICS AT 50 Hz, 2 POLES**

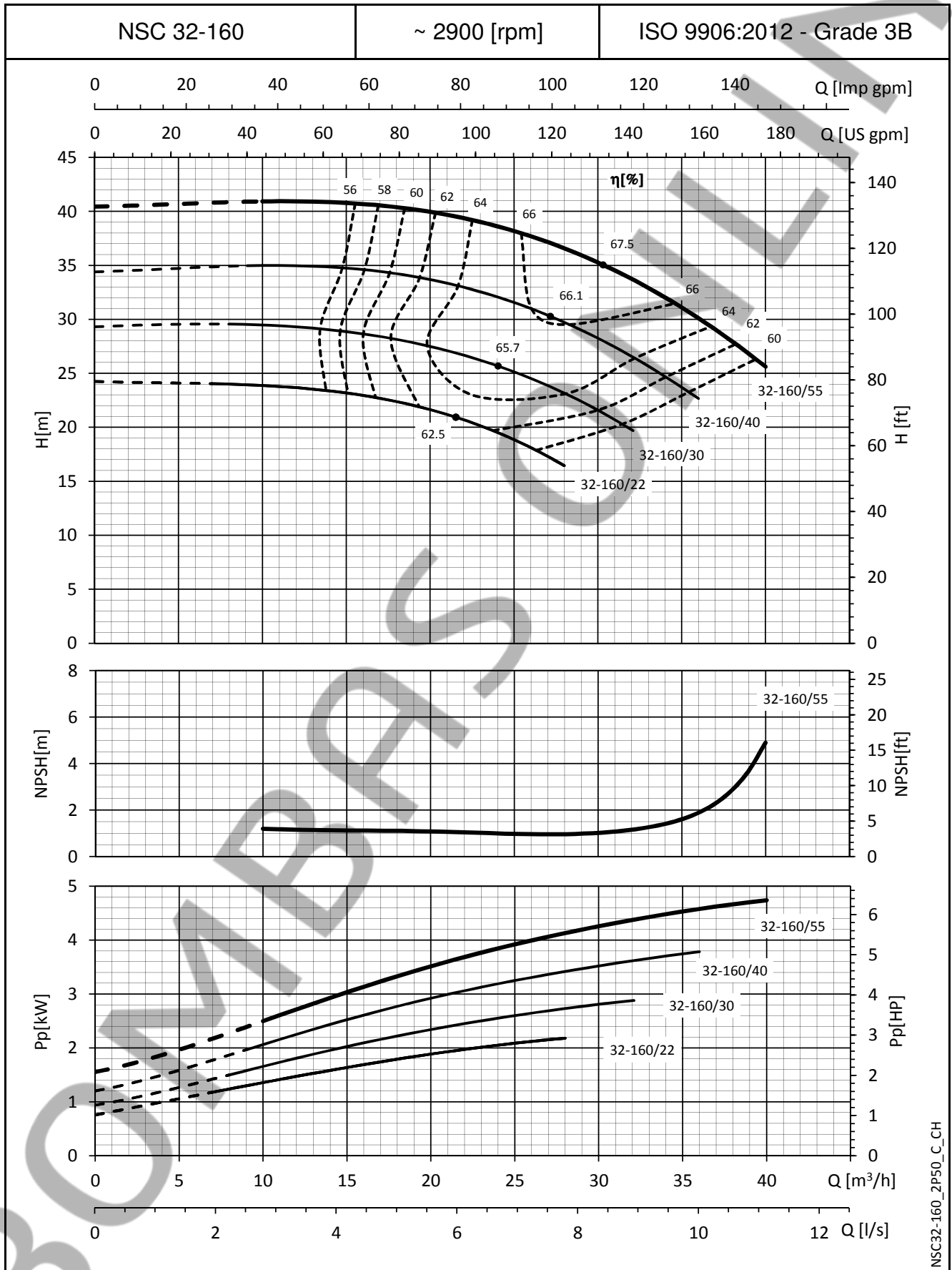

NSC32-160\_2P50\_C\_CH

The NPSH values are laboratory values; for practical use we suggest increasing these values by 0,5 m.  
These performances are valid for liquids with density  $\rho = 1,0 \text{ Kg/dm}^3$  and kinematic viscosity  $\nu = 1 \text{ mm}^2/\text{sec}$ .

**e-NSC SERIES**  
**OPERATING CHARACTERISTICS AT 50 Hz, 2 POLES**

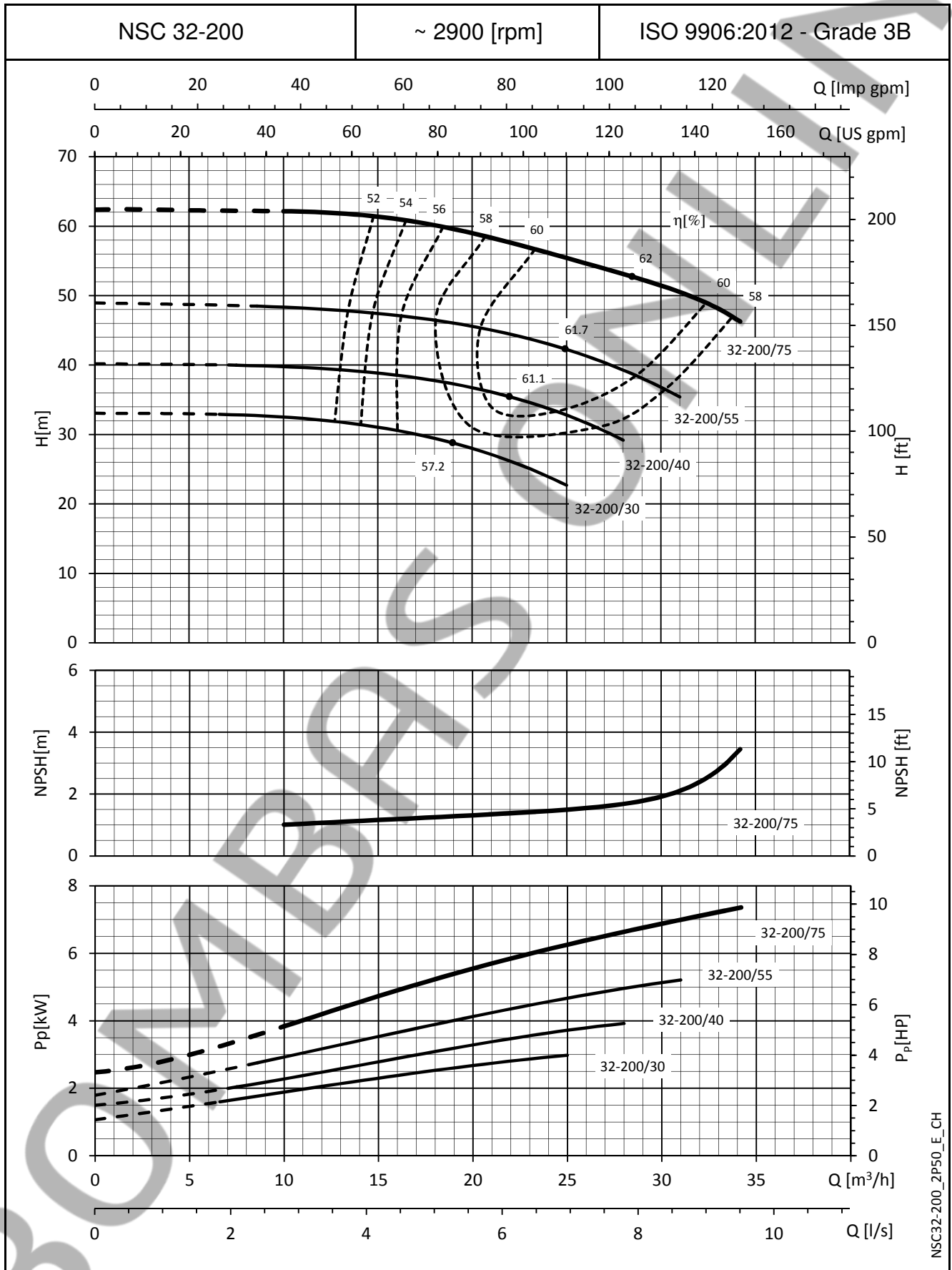

The NPSH values are laboratory values; for practical use we suggest increasing these values by 0,5 m.  
These performances are valid for liquids with density  $\rho = 1,0 \text{ Kg/dm}^3$  and kinematic viscosity  $\nu = 1 \text{ mm}^2/\text{sec}$ .

**e-NSC SERIES**  
**OPERATING CHARACTERISTICS AT 50 Hz, 2 POLES**

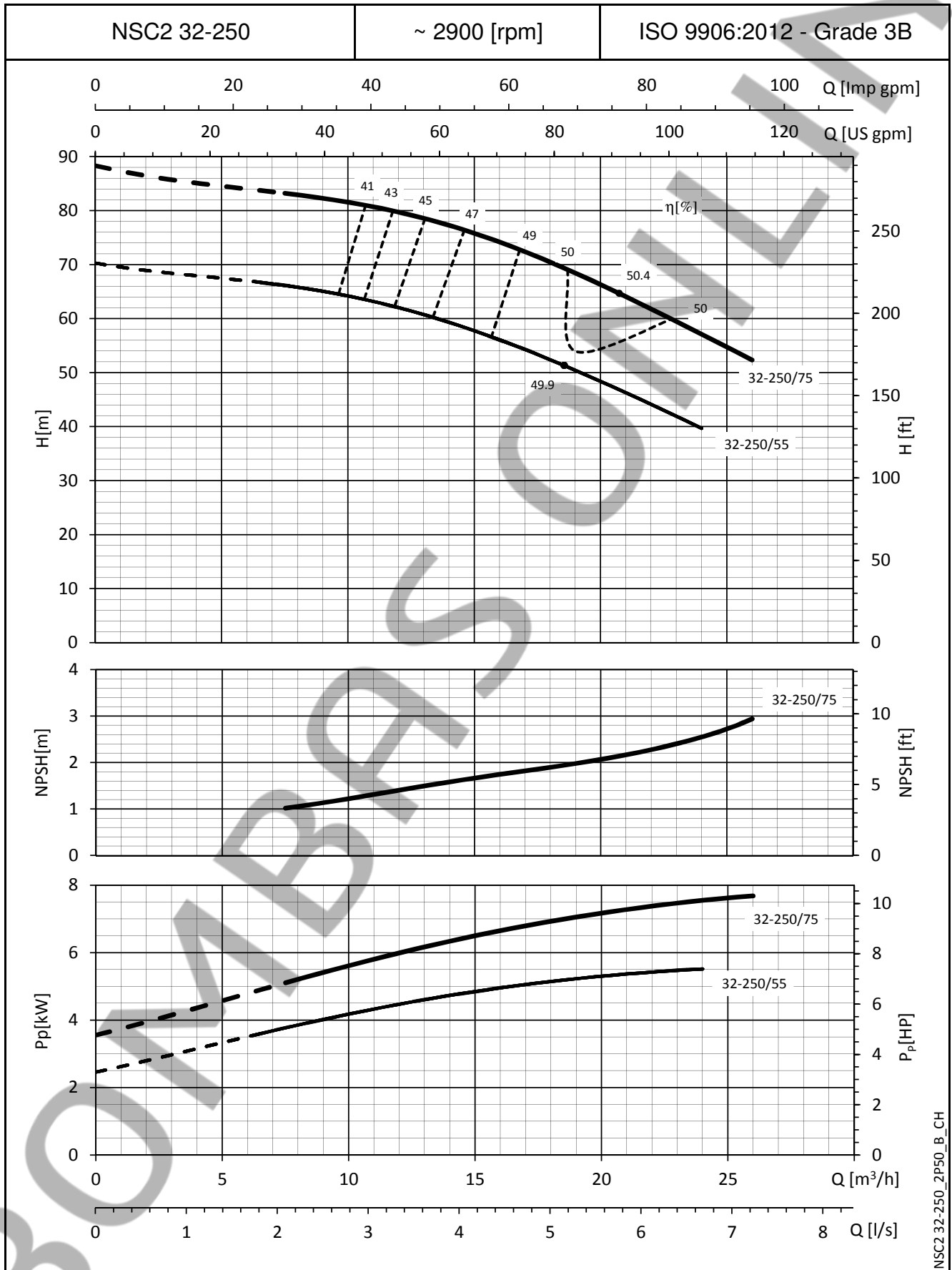

The NPSH values are laboratory values; for practical use we suggest increasing these values by 0,5 m.  
These performances are valid for liquids with density  $\rho = 1,0 \text{ Kg/dm}^3$  and kinematic viscosity  $\nu = 1 \text{ mm}^2/\text{sec}$ .

**e-NSC SERIES**  
**OPERATING CHARACTERISTICS AT 50 Hz, 2 POLES**

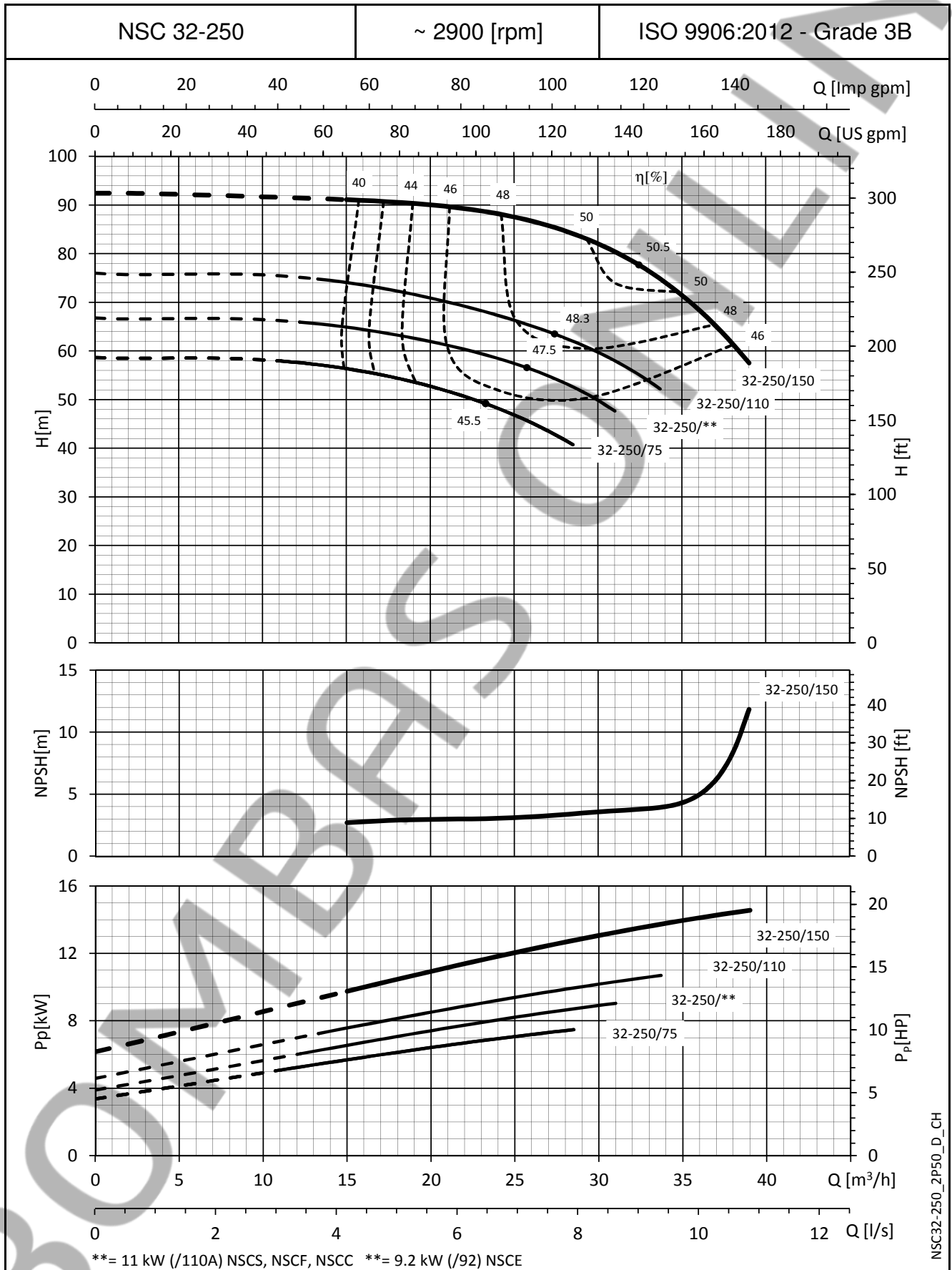

\*\*= 11 kW (/110A) NSCS, NSCF, NSCC    \*\*= 9.2 kW (/92) NSCE

The NPSH values are laboratory values; for practical use we suggest increasing these values by 0,5 m.  
These performances are valid for liquids with density  $\rho = 1,0 \text{ Kg/dm}^3$  and kinematic viscosity  $\nu = 1 \text{ mm}^2/\text{sec}$ .

**NSCF 32 SERIES (MOUNTED ON BASE)  
DIMENSIONS AND WEIGHTS AT 50 Hz, 2 POLES**

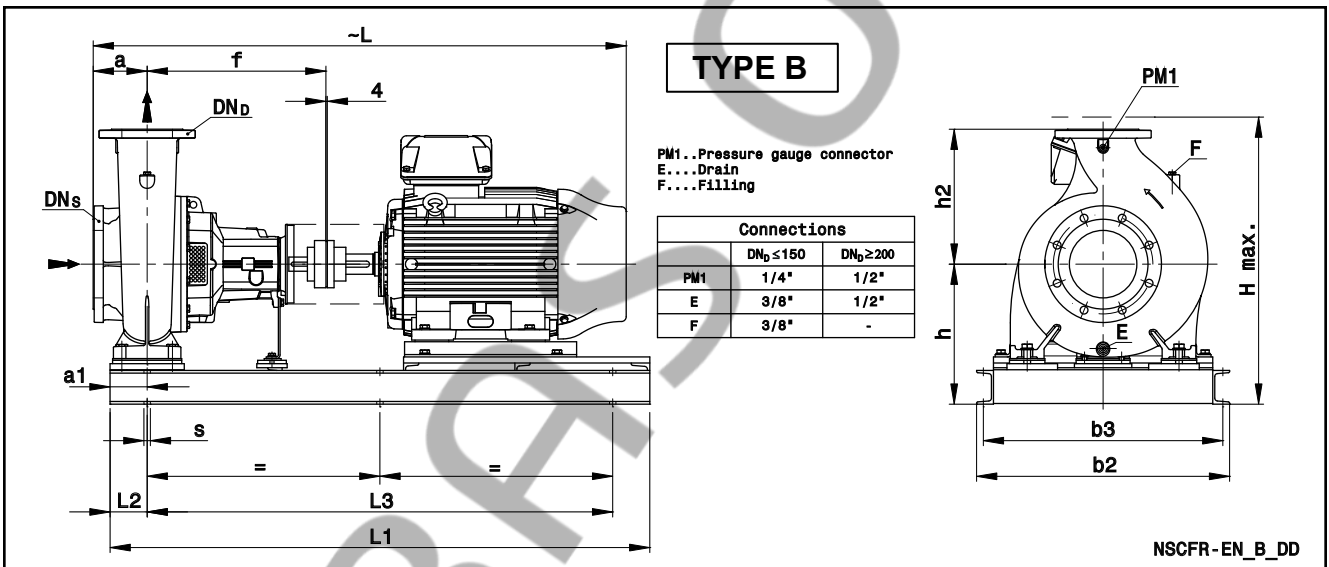
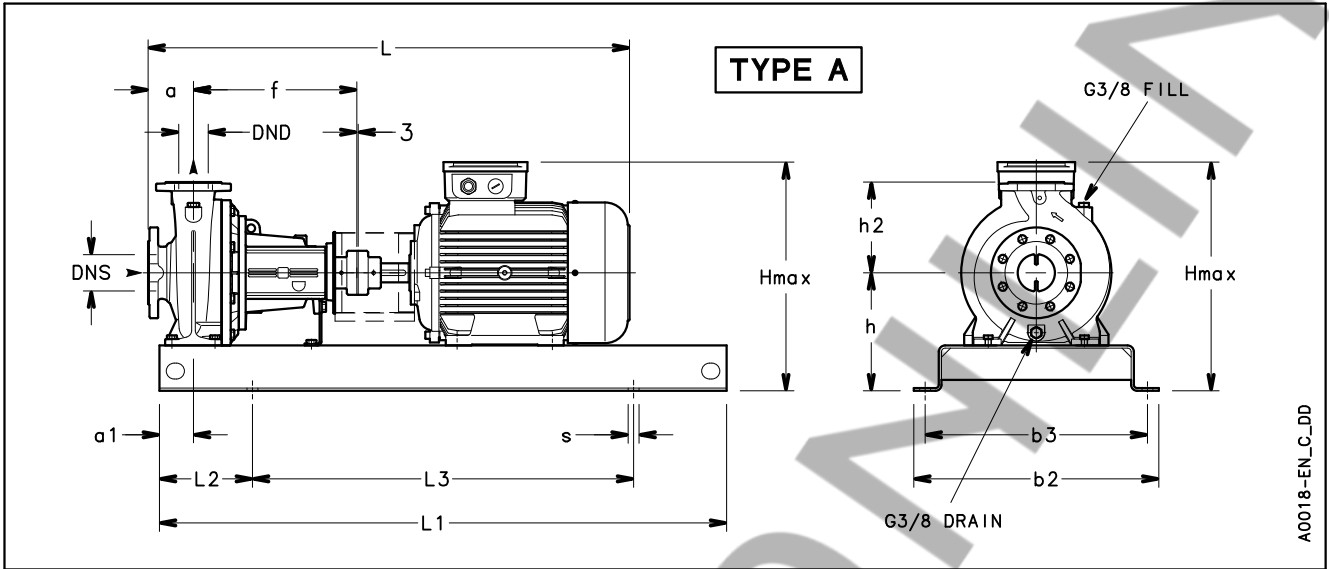

PUMP TYPE NSCF..2	TYPE	DIMENSIONS (mm)														H max	s FOR SCREWS	WEIGHT kg	COUPLING TYPE
		DNS	DND	a	a1	b2	b3	f	h	h2	L	L1	L2	L3					
32-125/11/S	A	50	32	80	60	360	320	360	212	140	746	800	130	540	352	4xØ19 (M16)	65	B68B	
32-125/15/P	A	50	32	80	60	390	350	360	212	140	791	900	150	600	352	4xØ19 (M16)	75	B68C	
32-125/22/P	A	50	32	80	60	390	350	360	212	140	791	900	150	600	352	4xØ19 (M16)	77	B68C	
32-125/30/P	A	50	32	80	60	390	350	360	212	140	822	900	150	600	366	4xØ19 (M16)	84	B80A	
32-160/22/P	A	50	32	80	60	390	350	360	232	160	791	900	150	600	392	4xØ19 (M16)	78	B68C	
32-160/30/P	A	50	32	80	60	390	350	360	232	160	822	900	150	600	392	4xØ19 (M16)	85	B80A	
32-160/40/P	A	50	32	80	60	390	350	360	232	160	825	900	150	600	400	4xØ19 (M16)	90	B80A	
32-160/55/P	A	50	32	80	60	450	400	360	232	160	890	1000	170	660	423	4xØ24 (M20)	119	B95A	
32-200/30/P	A	50	32	80	60	390	350	360	260	180	822	900	150	600	440	4xØ19 (M16)	92	B80A	
32-200/40/P	A	50	32	80	60	390	350	360	260	180	825	900	150	600	440	4xØ19 (M16)	97	B80A	
32-200/55/P	A	50	32	80	60	450	400	360	260	180	890	1000	170	660	451	4xØ24 (M20)	126	B95A	
32-200/75/P	A	50	32	80	60	450	400	360	260	180	890	1000	170	660	451	4xØ24 (M20)	130	B95A	
32-250/75/P	A	50	32	100	75	490	440	360	280	225	910	1120	190	740	505	4xØ24 (M20)	157	B95A	
32-250/110A/P	A	50	32	100	75	540	490	360	280	225	1067	1250	205	840	520	4xØ24 (M20)	187	B95B	
32-250/110/P	A	50	32	100	75	540	490	360	280	225	1067	1250	205	840	520	4xØ24 (M20)	187	B95B	
32-250/150/P	A	50	32	100	75	540	490	360	280	225	1067	1250	205	840	520	4xØ24 (M20)	204	B95B	

NOTE: Pumps with flanges according to EN 1092-2 as standard.

Nscf32\_2p50-en\_d\_td

Available ASME B16.5 version on request. For flanges dimensions see drawing.

## NSCF 40, 50, 65 SERIES (MOUNTED ON BASE) DIMENSIONS AND WEIGHTS AT 50 Hz, 2 POLES

PUMP TYPE NSCF..2	TYPE	DIMENSIONS (mm)														H max	S FOR SCREWS	WEIGHT kg	COUPLING TYPE
		DNS	DND	a	a1	b2	b3	f	h	h2	L	L1	L2	L3					
40-125/15/P	A	65	40	80	60	390	350	360	212	140	791	900	150	600	352	4xØ19 (M16)	76	B68C	
40-125/22/P	A	65	40	80	60	390	350	360	212	140	791	900	150	600	352	4xØ19 (M16)	78	B68C	
40-125/30/P	A	65	40	80	60	390	350	360	212	140	822	900	150	600	366	4xØ19 (M16)	85	B80A	
40-125/40/P	A	65	40	80	60	390	350	360	212	140	825	900	150	600	380	4xØ19 (M16)	90	B80A	
40-160/30/P	A	65	40	80	60	390	350	360	232	160	822	900	150	600	392	4xØ19 (M16)	86	B80A	
40-160/40/P	A	65	40	80	60	390	350	360	232	160	825	900	150	600	400	4xØ19 (M16)	91	B80A	
40-160/55/P	A	65	40	80	60	450	400	360	232	160	890	1000	170	660	423	4xØ24 (M20)	120	B95A	
40-160/75/P	A	65	40	80	60	450	400	360	232	160	890	1000	170	660	423	4xØ24 (M20)	124	B95A	
40-200/55/P	A	65	40	100	60	450	400	360	260	180	910	1000	170	660	451	4xØ24 (M20)	128	B95A	
40-200/75/P	A	65	40	100	60	450	400	360	260	180	910	1000	170	660	451	4xØ24 (M20)	132	B95A	
40-200/110A/P	A	65	40	100	60	490	440	360	260	180	1067	1120	190	740	500	4xØ24 (M20)	161	B95B	
40-200/110/P	A	65	40	100	60	490	440	360	260	180	1067	1120	190	740	500	4xØ24 (M20)	161	B95B	
40-250/110A/P	A	65	40	100	75	540	490	360	280	225	1067	1250	205	840	520	4xØ24 (M20)	188	B95B	
40-250/110/P	A	65	40	100	75	540	490	360	280	225	1067	1250	205	840	520	4xØ24 (M20)	188	B95B	
40-250/150/P	A	65	40	100	75	540	490	360	280	225	1067	1250	205	840	520	4xØ24 (M20)	205	B95B	
40-250/185/P	A	65	40	100	75	540	490	360	280	225	1067	1250	205	840	520	4xØ24 (M20)	218	B95B	
40-250/220/W	A	65	40	100	75	540	490	360	280	225	1127	1250	205	840	559	4xØ24 (M20)	285	B110A	
50-125/30/P	A	65	50	100	60	390	350	360	232	160	842	900	150	600	392	4xØ19 (M16)	88	B80A	
50-125/40/P	A	65	50	100	60	390	350	360	232	160	845	900	150	600	400	4xØ19 (M16)	93	B80A	
50-125/55/P	A	65	50	100	60	450	400	360	232	160	910	1000	170	660	423	4xØ24 (M20)	122	B95A	
50-125/75/P	A	65	50	100	60	450	400	360	232	160	910	1000	170	660	423	4xØ24 (M20)	126	B95A	
50-160/55/P	A	65	50	100	60	450	400	360	260	180	910	1000	170	660	451	4xØ24 (M20)	129	B95A	
50-160/75/P	A	65	50	100	60	450	400	360	260	180	910	1000	170	660	451	4xØ24 (M20)	133	B95A	
50-160/110A/P	A	65	50	100	60	490	440	360	260	180	1067	1120	190	740	500	4xØ24 (M20)	162	B95B	
50-160/110/P	A	65	50	100	60	490	440	360	260	180	1067	1120	190	740	500	4xØ24 (M20)	162	B95B	
50-200/110A/P	A	65	50	100	60	490	440	360	260	200	1067	1120	190	740	500	4xØ24 (M20)	163	B95B	
50-200/110/P	A	65	50	100	60	490	440	360	260	200	1067	1120	190	740	500	4xØ24 (M20)	163	B95B	
50-200/150/P	A	65	50	100	60	490	440	360	260	200	1067	1120	190	740	500	4xØ24 (M20)	180	B95B	
50-200/185/P	A	65	50	100	60	490	440	360	260	200	1067	1120	190	740	500	4xØ24 (M20)	193	B95B	
50-250/150/P	A	65	50	100	75	540	490	360	280	225	1067	1250	205	840	520	4xØ24 (M20)	206	B95B	
50-250/185/P	A	65	50	100	75	540	490	360	280	225	1067	1250	205	840	520	4xØ24 (M20)	219	B95B	
50-250/220/W	A	65	50	100	75	540	490	360	280	225	1127	1250	205	840	559	4xØ24 (M20)	286	B110A	
50-250/300/W	A	65	50	100	75	610	550	360	310	225	1230	1400	230	940	627	4xØ28 (M24)	368	B125D	
50-315/370/W	B	65	50	125	110	560	520	470	355	280	1366	1350	110	1130	672	6xØ19 (M16)	462	B125B	
50-315/450/W	B	65	50	125	110	560	520	470	355	280	1455	1350	110	1130	739	6xØ19 (M16)	607	B125B	
50-315/550/W	B	65	50	125	110	750	710	470	405	280	1564	1550	110	1330	807	6xØ19 (M16)	733	B140A	
50-315/750/W	B	65	50	125	110	750	710	470	405	280	1670	1550	110	1330	877	6xØ19 (M16)	960	B160A	
65-125/40/P	A	80	65	100	75	390	350	360	260	180	845	900	150	600	440	4xØ19 (M16)	104	B80A	
65-125/55/P	A	80	65	100	75	450	400	360	260	180	910	1000	170	660	451	4xØ24 (M20)	133	B95A	
65-125/75/P	A	80	65	100	75	450	400	360	260	180	910	1000	170	660	451	4xØ24 (M20)	137	B95A	
65-125/110A/P	A	80	65	100	75	490	440	360	260	180	1067	1120	190	740	500	4xØ24 (M20)	167	B95B	
65-125/110/P	A	80	65	100	75	490	440	360	260	180	1067	1120	190	740	500	4xØ24 (M20)	167	B95B	
65-160/75/P	A	80	65	100	75	450	400	360	260	200	910	1000	170	660	460	4xØ24 (M20)	158	B95A	
65-160/110A/P	A	80	65	100	75	540	490	360	260	200	1067	1250	205	840	500	4xØ24 (M20)	188	B95B	
65-160/110/P	A	80	65	100	75	540	490	360	260	200	1067	1250	205	840	500	4xØ24 (M20)	188	B95B	
65-160/150/P	A	80	65	100	75	540	490	360	260	200	1067	1250	205	840	500	4xØ24 (M20)	205	B95B	
65-160/185/P	A	80	65	100	75	540	490	360	260	200	1067	1250	205	840	500	4xØ24 (M20)	218	B95B	
65-200/110/P	A	80	65	100	75	540	490	360	280	225	1067	1250	205	840	520	4xØ24 (M20)	191	B95B	
65-200/150/P	A	80	65	100	75	540	490	360	280	225	1067	1250	205	840	520	4xØ24 (M20)	208	B95B	
65-200/185/P	A	80	65	100	75	540	490	360	280	225	1067	1250	205	840	520	4xØ24 (M20)	221	B95B	
65-200/220/W	A	80	65	100	75	540	490	360	280	225	1127	1250	205	840	559	4xØ24 (M20)	288	B110A	
65-200/300/W	A	80	65	100	75	610	550	360	310	225	1230	1400	230	940	627	4xØ28 (M24)	370	B125D	
65-250/220/W	A	80	65	100	90	540	490	470	310	250	1237	1250	205	840	589	4xØ24 (M20)	306	B110B	
65-250/300/W	A	80	65	100	90	610	550	470	310	250	1340	1400	230	940	627	4xØ28 (M24)	388	B125B	
65-250/370/W	A	80	65	100	90	610	550	470	310	250	1340	1400	230	940	627	4xØ28 (M24)	409	B125B	
65-250/450/W	A	80	65	100	90	610	550	470	365	250	1429	1400	230	940	749	4xØ28 (M24)	560	B125B	
65-250/550/W	A	80	65	100	90	660	600	470	390	250	1538	1600	270	1060	792	4xØ28 (M24)	669	B140A	
65-315/550/W	B	80	65	125	110	750	710	470	405	280	1564	1550	110	1330	807	6xØ19 (M16)	740	B140A	
65-315/750/W	B	80	65	125	110	750	710	470	390	280	1670	1550	110	1330	862	6xØ19 (M16)	958	B160A	
65-315/900/W	B	80	65	125	110	750	710	470	390	280	1670	1550	110	1330	862	6xØ19 (M16)	993	B160A	

NOTE: Pumps with flanges according to EN 1092-2 as standard.

Nscf40-65-2p50-en\_d\_td

Available ASME B16.5 version on request. For flanges dimensions see drawing.