

50 Hz



e-SH Series

HORIZONTAL CENTRIFUGAL ELECTRIC PUMPS ACCORDING TO EN 733
MADE IN AISI 316 STAINLESS STEEL AND EQUIPPED WITH **IE3** MOTORS

ErP 2009/125/EC

ESH 65, 80 SERIES HYDRAULIC PERFORMANCE RANGE AT 50 Hz, 4 POLES

PUMP TYPE	P _N kW	Ø Impeller (mm)		Q = DELIVERY													
		○ ● (1)	η _p % (2)	l/s	0	4,2	5,6	7,2	8,9	10,6	11,9	13,6	15,3	16,9	18,3	20,0	21,7
				m ³ /h	0	15	20	26	32	38	43	49	55	61	66	72	78
H = TOTAL HEAD METRES COLUMN OF WATER																	
65-160/05	0,55	127	○	69,1	4,7	3,7	3,2	2,7	2,2	1,6							
65-160/07	0,75	140	○	72,8	6,1	5,2	4,8	4,3	3,8	3,3	2,7						
65-160/11A	1,1	154	○	74,7	7,7	6,8	6,4	5,9	5,4	4,8	4,2	3,5	2,8				
65-160/11	1,1	164	○	73,9	8,7	7,8	7,4	6,9	6,4	5,9	5,3	4,7	4,0				
65-160/15	1,5	176	●	73,2	10,2	9,5	9,1	8,6	8,0	7,3	6,7	6,0	5,4	4,8			
65-200/15	1,5	187	○	67,4	12,1	10,6	10,0	9,3	8,6	7,8	7,0	6,1	5,2				
65-200/22	2,2	203	○	68,9	14,6	13,2	12,6	12,0	11,3	10,5	9,7	8,8	7,9	7,0			
65-200/30	3	219	●	70,8	17,5	16,3	15,9	15,3	14,8	14,1	13,4	12,6	11,7	10,8	9,8		
65-250/40	4	240	○	71,9	20,4		19,3	18,8	18,3	17,6	16,9	16,1	15,2	14,2	13,0		
65-250/55	5,5	255	●	71,0	23,7		23,1	22,6	22,0	21,4	20,7	19,9	19,1	18,1	17,1	16,0	14,7

PUMP TYPE	P _N kW	Ø Impeller (mm)		Q = DELIVERY													
		○ ● (1)	η _p % (2)	l/s	0	10,0	12,8	15,6	18,1	20,8	23,6	26,4	29,2	31,9	34,4	37,2	40,0
				m ³ /h	0	36	46	56	65	75	85	95	105	115	124	134	144
H = TOTAL HEAD METRES COLUMN OF WATER																	
80-160/15	1,5	169x15°	○	75,2	8,0	7,6	7,0	6,3	5,6	4,8	4,0	3,1					
80-160/22A	2,2	177	○	74,2	9,4	9,0	8,5	7,8	7,1	6,3	5,4	4,5	3,5				
80-160/22	2,2	186	●	73,4	10,8	10,4	9,9	9,2	8,5	7,7	6,8	5,9	4,9				
80-200/30	3	198	○	80,5	12,3		11,9	11,2	10,4	9,5	8,5	7,5	6,4	5,3			
80-200/40	4	220	●	78,3	15,4		15,3	14,7	13,9	13,0	12,1	11,1	10,1	9,0	7,9		
80-250/55	5,5	237	○	77,5	20,3		19,5	18,8	17,9	16,9	15,8	14,4	12,9	11,2	9,3		
80-250/75	7,5	252	○	76,7	23,1		22,2	21,6	20,8	19,9	19,0	17,8	16,6	15,2	13,6		
80-250/110	11	270	●	74,3	26,6		26,1	25,5	24,7	23,9	22,9	21,8	20,6	19,3	17,9	16,4	14,8

Hydraulic performances in compliance with ISO 9906:2012 - Grade 3B (ex ISO 9906:1999 - Annex A)

ESH-65-80_4p50-en_c_th

(1) ● = Full impeller diameter - ○ = Trimmed impeller diameter (2) Hydraulic efficiency of pump.

ESH SERIES
OPERATING CHARACTERISTICS AT 50 Hz, 4 POLES

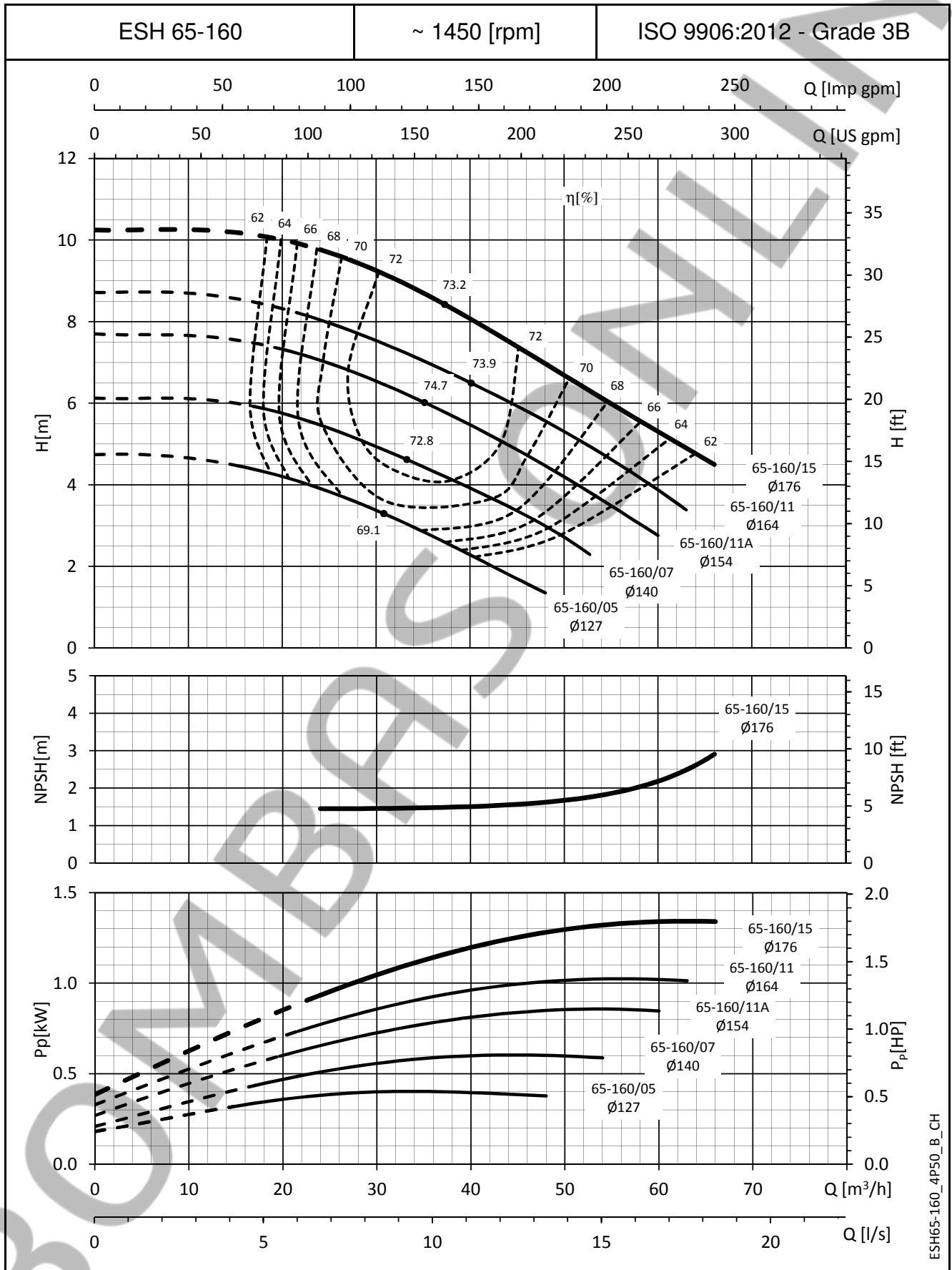

The NPSH values are laboratory values; for practical use we suggest increasing these values by 0,5 m.
These performances are valid for liquids with density $\rho = 1,0 \text{ Kg/dm}^3$ and kinematic viscosity $\nu = 1 \text{ mm}^2/\text{sec}$.

ESH SERIES
OPERATING CHARACTERISTICS AT 50 Hz, 4 POLES

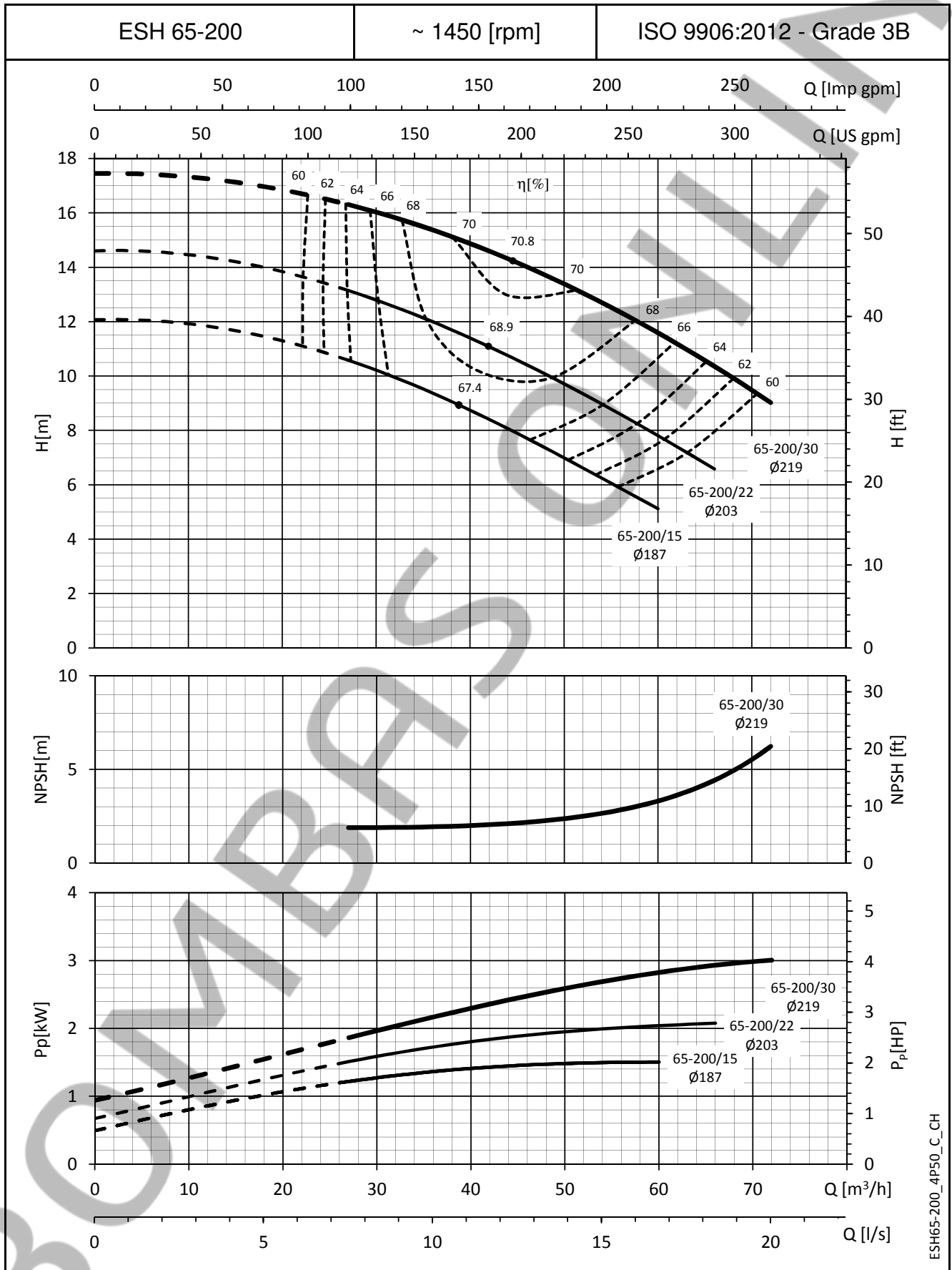

ESH65-200_4P50_C_CH

The NPSH values are laboratory values; for practical use we suggest increasing these values by 0,5 m.
These performances are valid for liquids with density $\rho = 1,0 \text{ Kg/dm}^3$ and kinematic viscosity $\nu = 1 \text{ mm}^2/\text{sec}$.

ESH SERIES
OPERATING CHARACTERISTICS AT 50 Hz, 4 POLES

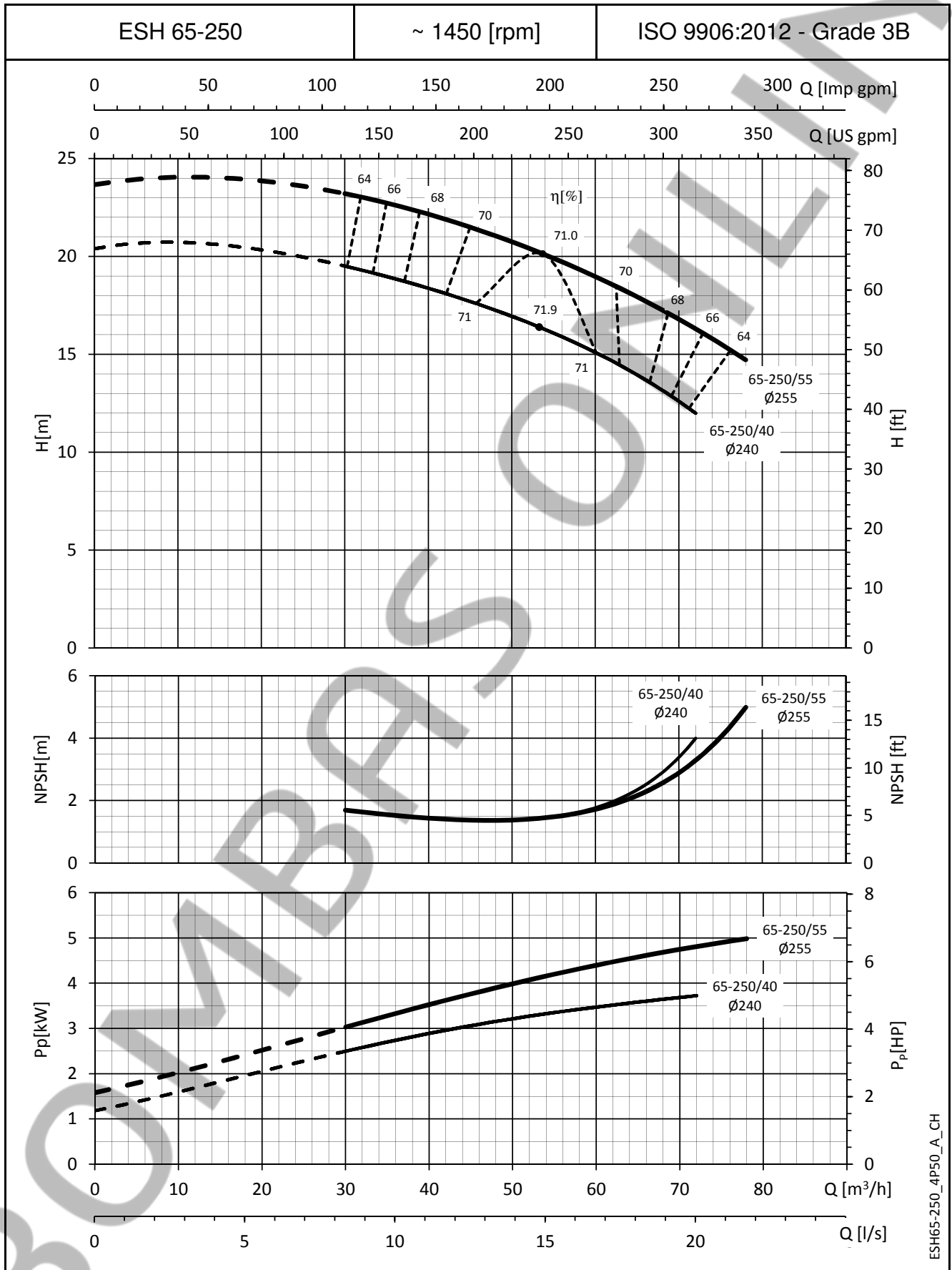

ESH65-250_4P50_A_CH

The NPSH values are laboratory values; for practical use we suggest increasing these values by 0,5 m.
These performances are valid for liquids with density $\rho = 1,0 \text{ Kg/dm}^3$ and kinematic viscosity $\nu = 1 \text{ mm}^2/\text{sec}$.

ESHS SERIES
DIMENSIONS AND WEIGHTS AT 50 Hz, 4 POLES

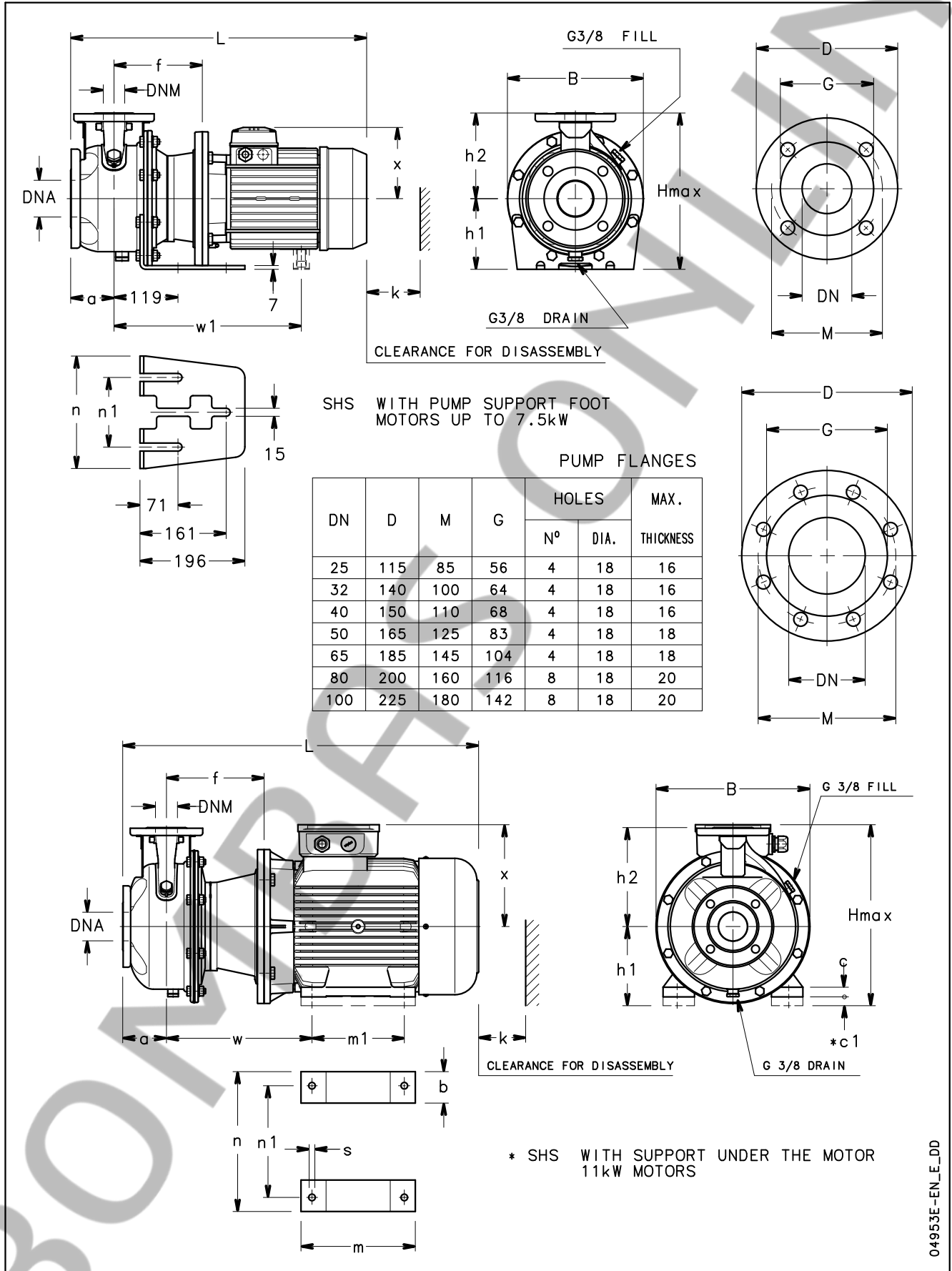

04953E-EN_E_DD

ESHS SERIES DIMENSIONS AND WEIGHTS AT 50 Hz, 4 POLES

PUMP TYPE ESHS..4	DIMENSIONS (mm)																			WEIGHT kg			
	PUMP											SUPPORT							B		H max	L	k
	DNM	DNA	a	f	h2	w	w1	x	b	c	*c1	h1	m	m1	n	n1	s						
25-250/07/X	25	50	100	155	225	-	-	128	-	-	-	180	-	-	265	130	-	345	405	486	98	42	
25-250/11/P	25	50	100	155	225	-	-	134	-	-	-	180	-	-	265	130	-	345	405	553	98	49	
25-250/15/P	25	50	100	155	225	-	-	134	-	-	-	180	-	-	265	130	-	345	405	553	98	50	
32-250/07/X	32	50	100	155	225	-	-	128	-	-	-	180	-	-	265	130	-	345	405	486	98	42	
32-250/11/P	32	50	100	155	225	-	-	134	-	-	-	180	-	-	265	130	-	345	405	553	98	49	
32-250/15/P	32	50	100	155	225	-	-	134	-	-	-	180	-	-	265	130	-	345	405	553	98	50	
40-200/07/X	40	65	100	155	180	-	-	128	-	-	-	160	-	-	230	130	-	284	340	486	100	31	
40-200/11/P	40	65	100	155	180	-	-	134	-	-	-	160	-	-	230	130	-	284	340	553	100	37	
40-250/11/P	40	65	100	155	225	-	-	134	-	-	-	180	-	-	265	130	-	345	405	553	107	51	
40-250/15/P	40	65	100	155	225	-	-	134	-	-	-	180	-	-	265	130	-	345	405	553	107	64	
40-250/22/P	40	65	100	165	225	-	-	168	-	-	-	180	-	-	265	130	-	345	405	587	107	68	
50-160/07/X	50	65	100	155	180	-	-	128	-	-	-	160	-	-	210	130	-	253	340	486	104	30	
50-160/11/P	50	65	100	155	180	-	-	134	-	-	-	160	-	-	210	130	-	253	340	553	104	36	
50-200/11/P	50	65	100	155	200	-	-	134	-	-	-	160	-	-	245	130	-	310	360	553	104	49	
50-200/15/P	50	65	100	155	200	-	-	134	-	-	-	160	-	-	245	130	-	310	360	553	104	52	
50-250/22A/P	50	65	100	165	225	-	-	168	-	-	-	180	-	-	265	130	-	345	405	587	107	58	
50-250/22/P	50	65	100	165	225	-	-	168	-	-	-	180	-	-	265	130	-	345	405	587	107	59	
50-250/30/P	50	65	100	165	225	-	-	168	-	-	-	180	-	-	265	130	-	345	405	618	107	65	
65-160/05/S	65	80	100	155	200	-	-	129	-	-	-	160	-	-	245	130	-	310	360	518	130	34	
65-160/07/X	65	80	100	155	200	-	-	128	-	-	-	160	-	-	245	130	-	310	360	486	130	38	
65-160/11A/P	65	80	100	155	200	-	-	134	-	-	-	160	-	-	245	130	-	310	360	553	130	46	
65-160/11/P	65	80	100	155	200	-	-	134	-	-	-	160	-	-	245	130	-	310	360	553	130	48	
65-160/15/P	65	80	100	155	200	-	-	134	-	-	-	160	-	-	245	130	-	310	360	553	130	51	
65-200/15/P	65	80	100	155	225	-	-	134	-	-	-	180	-	-	245	130	-	310	405	553	130	54	
65-200/22/P	65	80	100	165	225	-	-	168	-	-	-	180	-	-	245	130	-	310	405	587	130	71	
65-200/30/P	65	80	100	165	225	-	-	168	-	-	-	180	-	-	245	130	-	310	405	618	130	72	
65-250/40/P	65	80	100	165	250	-	380	168	-	-	-	200	-	-	265	130	-	345	450	663	140	97	
65-250/55/P	65	80	100	192	250	-	435	191	-	-	-	200	-	-	265	130	-	345	450	697	140	104	
80-160/15/P	80	100	125	155	225	-	-	134	-	-	-	180	-	-	265	130	-	345	405	578	160	59	
80-160/22A/P	80	100	125	165	225	-	-	168	-	-	-	180	-	-	265	130	-	345	405	612	160	67	
80-160/22/P	80	100	125	165	225	-	-	168	-	-	-	180	-	-	265	130	-	345	405	612	160	67	
80-200/30/P	80	100	125	165	250	-	-	168	-	-	-	180	-	-	265	130	-	345	430	643	160	72	
80-200/40/P	80	100	125	165	250	-	380	168	-	-	-	180	-	-	265	130	-	345	430	688	160	88	
80-250/55/P	80	100	125	192	280	-	435	191	-	-	-	200	-	-	303	210	-	383	480	722	160	107	
80-250/75/P	80	100	125	192	280	-	435	191	-	-	-	200	-	-	303	210	-	383	480	722	160	113	
80-250/110/P	80	100	125	222	280	330	-	240	49	5	40	200	304	210	304	254	15	383	480	841	160	153	

* Motor shim on request

ESHS_4p50-en_b_td