

# VERTY NOVA

## INTEGRATED FLOAT SWITCH SUBMERSIBLE PUMPS



### DRAINAGE CLEAR WATER FOR DOMESTIC USE

Submersible pumps specifically designed for uses in narrow pits with dimensions down to 20 cm x 20 cm. Suitable to pump clear water containing particles with maximum diameter up to 5 mm.

**Pump with built-in float switch.**

Anti-corrosive and rust-proof materials.

Integrated float switch.

Low suction capability: 2 – 3 mm (manual mode).

Very low priming and starting level of the pump: 10 – 15 mm (manual mode).

Knob for manual or automatic operation.

Easy access through sliding cover to float switch for cleaning.

Motor with thermal overload protection.

Excellent cooling of the motor that enables the pump to operate even when it is partially submersible.

Supplied with power cable with plug, non return valve and 4-step fitting.

## TECHNICAL DATA

MODEL	CODE	ELECTRICAL DATA				
		VOLTAGE 50 HZ	P1 MAX KW	P2 NOMINAL		In A
				KW	HP	
VERTY NOVA 200 M	60122636	1X230 V~	0,3	0,2	0,28	1,3
VERTY NOVA 400 M	60122637	1X230 V~	0,6	0,4	0,55	2,6

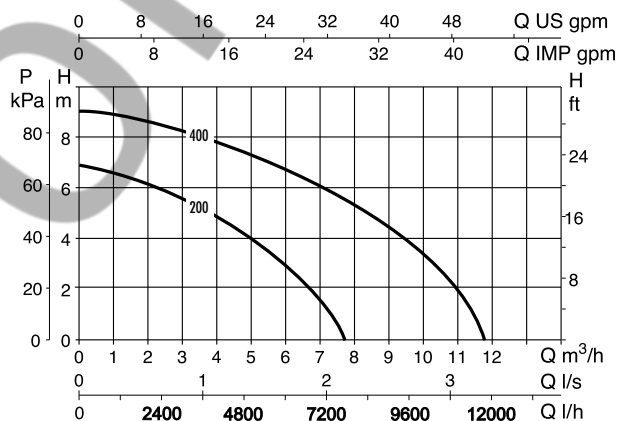

## DIMENSIONS AND WEIGHTS

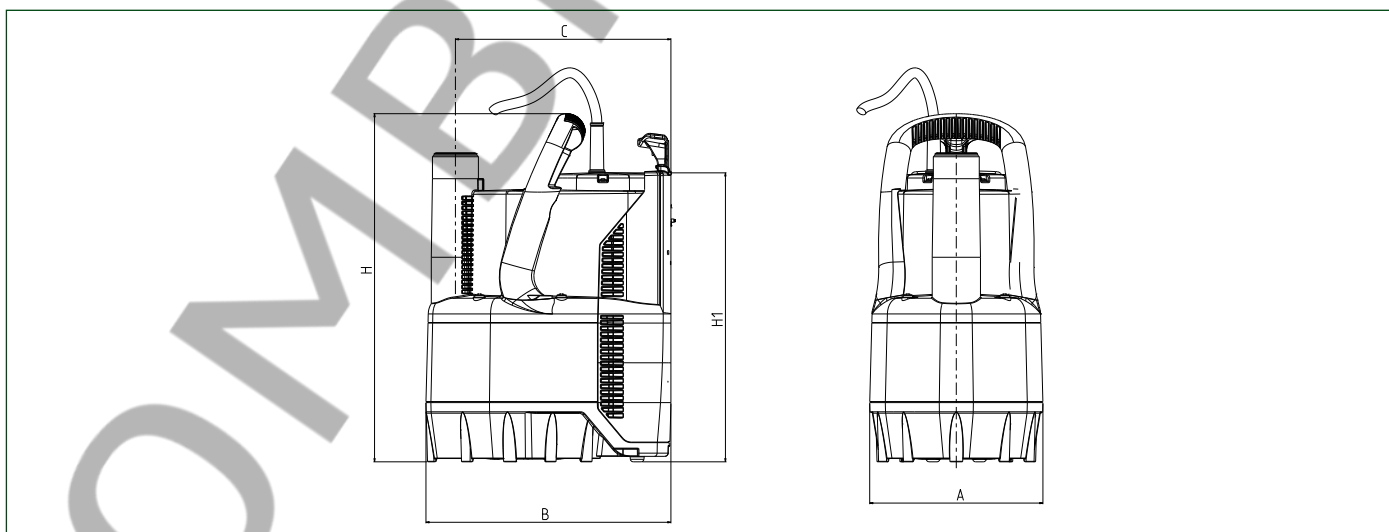

MODEL	A	B	C	ØD	H	H1	DNM GAS	CABLE	Q.TY X PALLETS	WEIGHT KG
VERTY NOVA 200 M	158	225	200	33	400	265	1/4"	10 mt.	40	4,2
VERTY NOVA 400 M	158	225	200	33	400	265	1/4"	10 mt.	40	5,1